



유일연삭기주식회사
YOUIL GRINDING MACHINE CO.,LTD.



- **精密自動平面研削機**
PRECISION SURFACE GRINDING MACHINE
- **精密成形研削機**
PRECISION FORMING GRINDING MACHINE



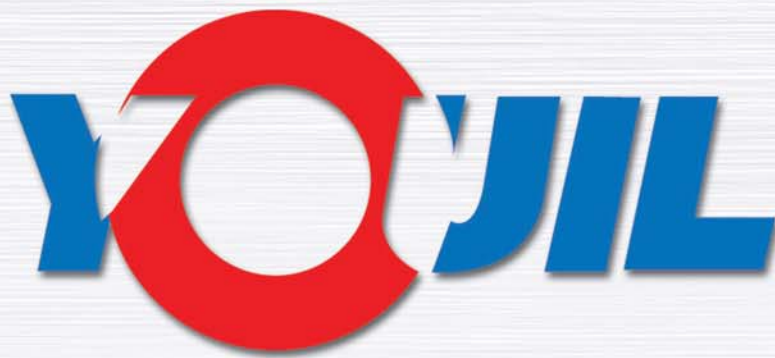
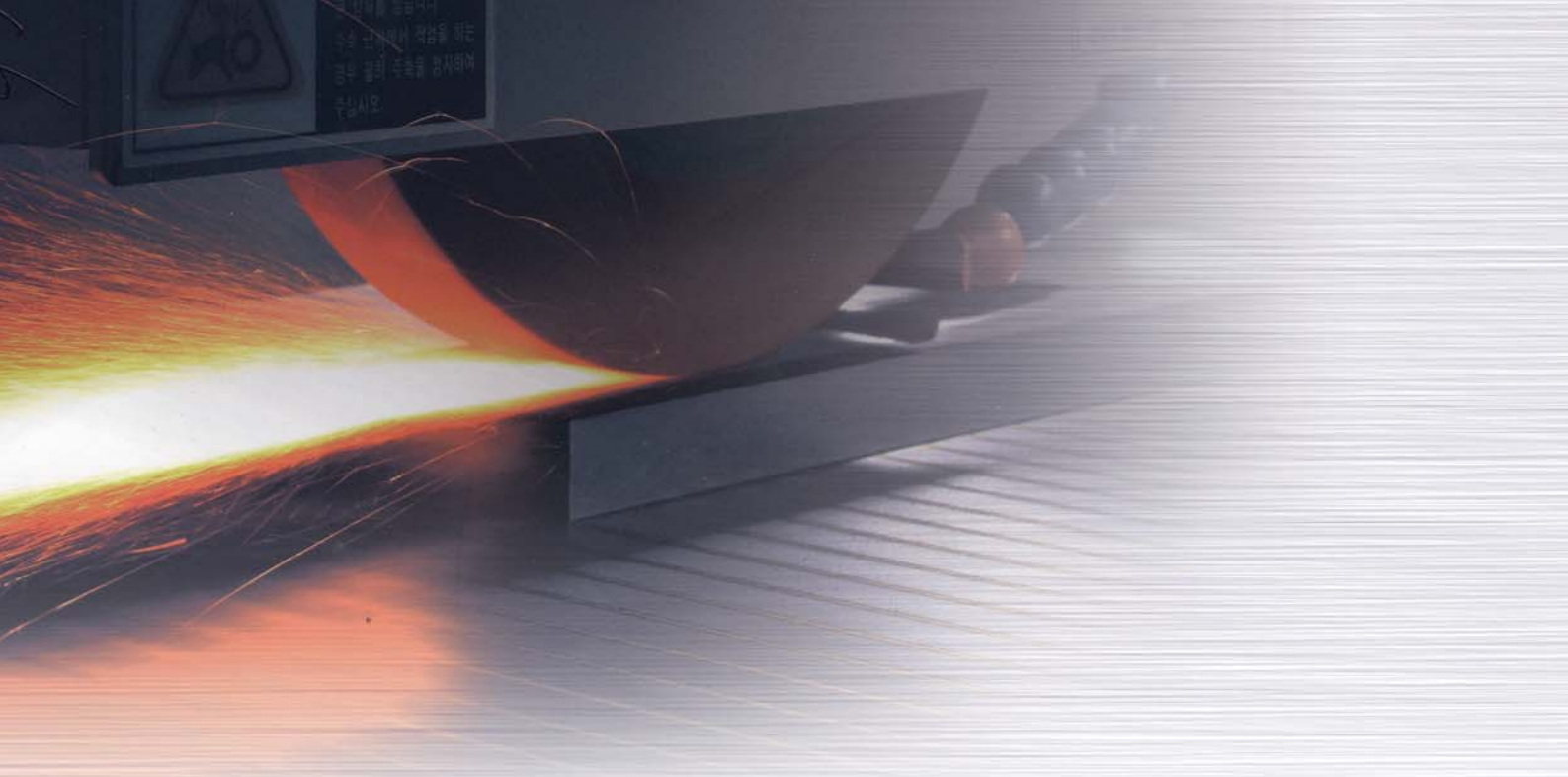

**저희는 끊임없는 연구 개발로
최고의 연삭기만을
만들기 위해 노력하고 있습니다.**

We make efforts to manufacture the best grinding machine through continuous research and development.

저희는 평면연삭기 전문 제조업체로서, 1986년 설립이후 고강성, 고정도, 고생산성 연삭기 제조를 경영목표로 삼아 끊임없는 연구개발과 고객의 의견을 반영하여 제품의 품질과 성능을 발전시켜왔고, 앞으로도 만족하지 않고 더욱 겸손한 마음으로 최고의 연삭기를 생산하기 위한 노력을 계속할 것입니다.

생산품목 / Products Guide



Group I. 정밀 성형 연삭기 Series

- 전자동 · 좌우자동 · 수동 Type
PRECISION FORMING GRINDING MACHINE
- YGS-46B (Table Size 500 × 150)
- YGS-52B (Table Size 500 × 200)
- YGS-46 (Table Size 500 × 150)
- YGS-46XA (Table Size 500 × 150)
- YGS-50A (Table Size 500 × 150)



Group II. 자동 평면 연삭기 Series

- SADDLE TYPE SURFACE GRINDING MACHINE
- YGS-52A (Table Size 550 × 200)
- YGS-63A (Table Size 650 × 300)
- YGS-65A (Table Size 650 × 500)
- YGS-96A (Table Size 850 × 500)
- YGS-116A (Table Size 1050 × 500)
- YGS-137A (Table Size 1250 × 600)



Group III. 대형 자동 평면 연삭기 Series

- COLUMN TYPE SURFACE GRINDING MACHINE
- YGS-1360SCZ (Table Size 1350 × 600)
- YGS-1670SCZ (Table Size 1650 × 700)
- YGS-2280SCZ (Table Size 2050 × 800)
- YGS-3080SCZ (Table Size 3050 × 800)
- YGS-2290SCZ (Table Size 2050 × 900)
- YGS-2590SCZ (Table Size 2550 × 900)



Group IV. 문형 평면 연삭기 Series

- DOUBLE COLUMN TYPE SURFACE GRINDING MACHINE
- YGS-2512SCYZ (Table Size 2550 × 1200)
- YGS-3015SCYZ (Table Size 3050 × 1500)
- YGS-3018SCYZ (Table Size 3050 × 1800)
- YGS-4320SCYZ (Table Size 4150 × 2000)
- YGS-6022SCYZ (Table Size 6050 × 2200)



Group V. CNC 연삭기 Series / Servo Control 평면 연삭기 Series

- COMPUTERIZED NUMERICAL CONTROL SURFACE GRINDING MACHINE
- SERVO CONTROL SADDLE TYPE SURFACE GRINDING MACHINE
- YGS-52SCZ / SCYZ YGS-96SCZ / SCYZ
- YGS-63SCZ / SCYZ YGS-116SCZ / SCYZ
- YGS-65SCZ / SCYZ YGS-137SCZ / SCYZ
- SERVO CONTROL COLUMN TYPE SURFACE GRINDING MACHINE
- YGS-1360SCYZ YGS-3080SCYZ
- YGS-1670SCYZ YGS-2290SCYZ
- YGS-2280SCYZ YGS-2590SCYZ

GROUP I

정밀 성형 연삭기 시리즈

PRECISION FORMING SURFACE GRINDING MACHINE

특징 Main Feature

본 Series는 500×150(200)mm의 연삭 용량을 갖춘 초정밀 성형 연삭기로 다양한 금형, 치공구, IT산업분야의 정밀 부품 연삭을 능률적으로 행할 수 있도록 선택폭이 넓게 구성되어 있음

- 수동(Manual) : YGS-46(Bed), YGS-52B, 46B (Ball type)
- 좌우자동(X-Auto, Y, Z-Manual) : YGS-46XA
- 전자동(X, Y, Z-Auto) : YGS-50A



■ Model : YGS-50A



■ Model : YGS-46



■ Model : YGS-52B

제 원 Specification

항목 Item		단위 unit	YGS-46B	YGS-52B	YGS-46	YGS-46XA	YGS-50A	
Capacity	테이블 면적 (길이 × 폭) Table size	mm	500 × 150	500 × 200	500 × 150	500 × 150	500 × 150	
	표준척의 크기 (길이 × 폭) Electric magnetic chuck size	mm	400 × 150 (미세)	450 × 200 (미세)	450 × 150	450 × 150	450 × 150	
	테이블 상면에서 스톨 중심까지의 거리 Max. distance between table surface and grinding wheel center	mm	0 ~ 465	0 ~ 540	0 ~ 465	0 ~ 465	0 ~ 500	
Table	최우 이동 속도 (평균) Traverse speed range		m/min	-	-	-	0.3 ~ 20	0.3 ~ 20
	전후 수동이송 Manual Cross Feed	현물 1회전당 이송량 Feed per revolution of handwheel	mm	5	5	5	5	5
		다이얼 1눈금당 이송량 Feed per graduation of handwheel	mm	0.02	0.02	0.02	0.02	0.02
	전후 자동이송 Automatic Cross Feed	간헐이송 (Step) Intermittent feed	mm	-	-	-	-	0.5 ~ 15
		연속이송 Continuous feed	m/min	-	-	-	-	0.1 ~ 1.0
자동 잘림 이송량 Automatic Down Feed		mm	-	-	-	-	0.002 ~ 0.03	
Grinding head	수동 잘림 이송량 Manual down feed	미세 이송량 Fine feed	다이얼 1회전당 이송량 Feed per revolution of dia	mm	0.05	0.05	0.05	-
		다이얼 1눈금당 이송량 Feed per graduation of dia	mm	0.001	0.001	0.001	0.001	-
			현물 1회전당 이송량 Feed per revolution of handwheel	mm	2	2	2	1.5
			다이얼 1눈금당 이송량 Feed per graduation of handwheel	mm	0.01	0.01	0.01	0.005
Grinding Wheel	외경 × 폭 × 내경 Diameter × Width × Bore		mm	∅180 × 9 ~ 20 × ∅31.75	∅180 × 9 ~ 20 × ∅31.75	∅180 × 9 ~ 20 × ∅31.75	∅180 × 9 ~ 20 × ∅31.75	∅180 × 9 ~ 20 × ∅31.75
	회전수 (50Hz / 60Hz) Spindle Speed		r.p.m	3000 / 3600	3000 / 3600	3000 / 3600	3000 / 3600	3000 / 3600
Motor	스핀들용 Grinding wheel spindle motor		Kw/p	1.5 / 2	1.5 / 2	1.5 / 2	1.5 / 2	1.5 / 2
	유압펌프용 Hydraulic pump motor		Kw/p	-	-	-	0.75 / 4	0.75 / 4
기계중량 (약) Net weight of machine (about)		kg	1200	1300	1300	1500	1350	

외 형 도 Dimension

■ YGS-46B, 52B, 46, 46XA, 50A

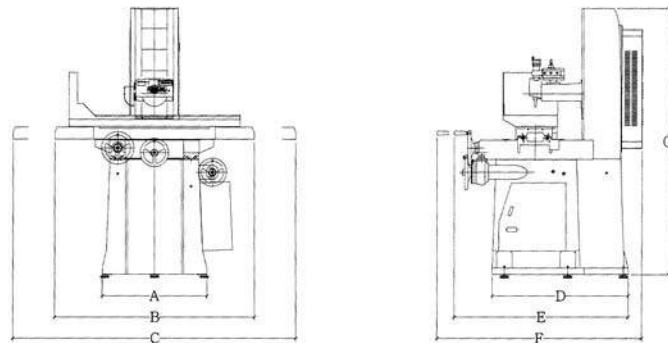

구 분	A	B	C	D	E	F	G
YGS-46B	720	1450	1970	880	1280	1410	1800
YGS-52B	740	1460	2020	950	1370	1500	1925
YGS-46	720	1450	1970	880	1280	1410	1800
YGS-46XA	720	1450	1970	880	1280	1410	1800
YGS-50A	720	1530	2240	740	1270	1410	1830

GROUP II 자동 평면 연삭기 시리즈

SADDLE TYPE SURFACE GRINDING MACHINE

특징 Main Feature

본 Series는 Saddle Type 평면 연삭기로서 다양한 크기로 구성되어 있으며, 대형부품 · 각종 금형류 등을 고능률 · 고정도로 연삭 할 수 있는 최강의 범용 연삭기임

- 고정도의 Spindle, 진동과 소음이 적은 Spindle motor
 - 정밀연삭에 적합하고, 긴 수명을 유지함
- 고강성 구조에 의한 집중 연구 설계 · 제작
 - 내구성이 우수하며 중(重)연삭이 가능함
- 4점지지 방식의 전후 이송 안내면
 - 중앙에 V&V홈 안내면과 양단에 대형기중(137A)은 LM Guide, 중형기중(96A)은 특수 열처리 베어링 안내면을 사용한 4점지지 방식으로 고정도를 오래도록 지속 할 수 있음



■ Model : YGS-137A



■ Model : YGS-116A



■ Model : YGS-65A

제 원 Specification

항목 Item		단위 Unit	YGS-52A	YGS-63A	YGS-65A	YGS-96A	YGS-116A	YGS-137A
Capacity	테이블 면적 (길이 × 폭) Table size	mm	550×200	650×300	650×500	850×500	1050×500	1250×600
	표준척의 크기 (길이 × 폭) Electric magnetic chuck size	mm	500×200	600×300	600×500	800×500	1000×500	1200×600
	테이블 상면에서 스톨 중심까지 거리 Max. distance between table surface and grinding wheel center	mm	0 ~ 500	0 ~ 522	0 ~ 697	0 ~ 697	0 ~ 697	0 ~ 845
Table	최우 이동 속도 (평균) Traverse speed range	m/min	0.3 ~ 20	0.5 ~ 20	0.5 ~ 20	0.5 ~ 20	0.5 ~ 20	0.5 ~ 20
	전후 수동이송 Manual Cross Feed	한들 회전당 이송량 Feed per revolution of handwheel	mm	5	5	5	5	5
		다이얼 눈금당 이송량 Feed per graduation of handwheel	mm	0.02	0.02	0.02	0.02	0.02
	전후 자동이송 Automatic Cross Feed	간헐이송 (Step) Intermittent feed	mm	0.5 ~ 15	0.5 ~ 20	0.5 ~ 20	0.5 ~ 20	0.5 ~ 20
연속이송 Continuous feed		m/min	0.1 ~ 1.0	0.1 ~ 1.0	0.1 ~ 1.0	0.1 ~ 1.0	0.1 ~ 1.0	
Grinding head	자동 잘림 이송량 Automatic Down Feed		mm	0.002 ~ 0.003	0.002 ~ 0.03	0.002 ~ 0.03	0.002 ~ 0.03	0.002 ~ 0.03
	수동 잘림 이송량 Manual down feed	한들 회전당 이송량 Feed per revolution of handwheel	mm	1.0	1.0	1.0	1.0	0.5
		다이얼 눈금당 이송량 Feed per graduation of handwheel	mm	0.005	0.005	0.005	0.005	0.005
Grinding Wheel	외경 × 폭 × 내경 Diameter × Width × Bore	mm	Ø205×19×Ø50.8	Ø355/Ø305×38×Ø127	Ø355/Ø305×38×Ø127	Ø355/Ø305×38×Ø127	Ø355/Ø305×50×Ø127	Ø510×50×Ø127
	회전수 (50Hz/60Hz) Spindle Speed	r.p.m	3000 / 3600	1500 / 1800	1500 / 1800	1500 / 1800	1500 / 1800	1000 / 1200
Motor	스핀들용 Grinding wheel spindle motor	Kw/p	1.5 / 2	3.7 / 4	3.7 / 4	3.7 / 4	5.5 / 4	7.5 / 6
	유압펌프용 Hydraulic pump motor	Kw/p	0.75 / 4	2.2 / 4	2.2 / 4	2.2 / 4	3.7 / 4	3.7 / 4
기계중량 (약) Net weight of machine (about)		kg	2000	2500	3300	5300	5900	6800

외 형 도 Dimension

■ YGS-52A, 63A, 65A, 96A, 116A, 137A

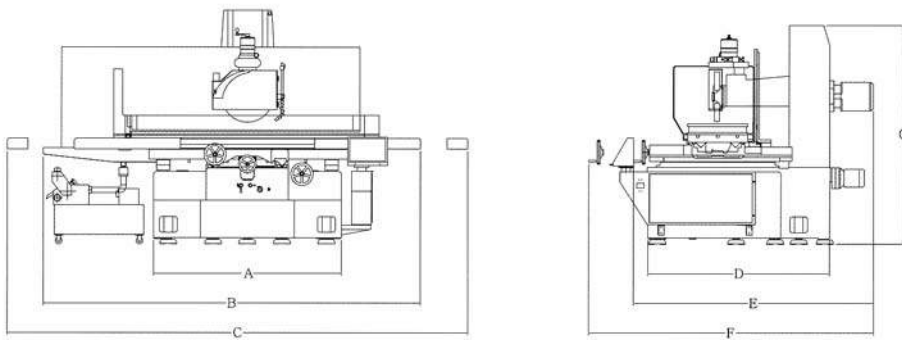

구 분	A	B	C	D	E	F	G
YGS-52A	720	1620	2600	940	1450	1680	1990
YGS-63A	830	2210	2700	1154	1874	2204	2050
YGS-65A	830	2210	2720	1480	2200	2530	2070
YGS-96A	1390	2750	3320	1480	2200	2530	2070
YGS-116A	1596	3362	4360	1586	2350	2610	2150
YGS-137A	1900	3840	4800	1780	2650	2990	2400

GROUP III 대형 자동 평면 연삭기 시리즈

COLUMN TYPE SURFACE GRINDING MACHINE

특징 Main Feature

본 Series는 Column Type 평면 연삭기로서 전후 가공폭 600mm에서 800mm까지 기종의 오랜 제작 경험에서 축적된 Know-How를 바탕으로 단일 Column 방식의 한계를 극복한 Work 폭 900mm를 가공할 수 있는 기종까지 다양하게 구성되어 있음

- 중(重) 연삭에서 정밀 연삭까지 광범위한 연삭조건에 적합
 - Base, Column, Table등 고강성 구조로 설계·제작되어 고정도를 오래 유지할 수 있음
- 인체공학적 디자인으로 작업이 편리함
 - Handle은 Base전면에 집중배치
 - 전후 이송거리를 Control Pane에서 설정이송 가능
 - 조작이 간편함



■ Model : YGS-2290SCZ



■ Model : YGS-1670SCZ



■ Model : YGS-1360SCZ

제 원 Specification

항목 Item		단위 Unit	YGS-1360SCZ	YGS-1670SCZ	YGS-2280SCZ	YGS-3080SCZ	YGS-2290SCZ	YGS-2590SCZ	
Capacity	테이블 면적 (길이 × 폭) Table size	mm	1350 × 600	1650 × 700	2050 × 800	3050 × 800	2050 × 900	2550 × 900	
	표준척의 크기 (길이 × 폭) Electric magnetic chuck size	mm	1300 × 600	1600 × 700	2000 × 800	3000 × 800	2000 × 900	2500 × 900	
	테이블 상면에서 스톨 중심까지의 거리 Max. distance between table surface and grinding wheel center	mm	0 ~ 845	0 ~ 950	0 ~ 950	0 ~ 950	0 ~ 950	0 ~ 950	
Table	최우 이동 속도 (평균) Traverse speed range	m/min	0 ~ 25	0 ~ 25	0 ~ 25	0 ~ 25	0 ~ 25	0 ~ 25	
	전후 수동이송 Manual Cross Feed	핸들 회전당 이송량 Feed per revolution of handwheel	mm	5	5	5	5	5	5
		다이얼 눈금당 이송량 Feed per graduation of handwheel	mm	0.025	0.025	0.025	0.025	0.025	0.025
	전후 자동이송 Automatic Cross Feed	간헐이송 (Step) Intermittent feed	mm	2 ~ 15	2 ~ 15	2 ~ 15	2 ~ 15	2 ~ 15	2 ~ 15
연속이송 Continuous feed		m/min	0.2 ~ 1.0	0.2 ~ 1.0	0.2 ~ 1.0	0.2 ~ 1.0	0.2 ~ 1.0	0.2 ~ 1.0	
Grinding head	자동 절입 이송량 Automatic Down Feed		mm	0.001 ~ 0.03	0.001 ~ 0.03	0.001 ~ 0.03	0.001 ~ 0.03	0.001 ~ 0.03	0.001 ~ 0.03
	수동 절입 이송량 Manual down feed	핸들 회전당 이송량 Feed per revolution of handwheel	mm	0.1, 1.0, 2.5	0.1, 1.0, 2.5	0.1, 1.0, 2.5	0.1, 1.0, 2.5	0.1, 1.0, 2.5	0.1, 1.0, 2.5
		다이얼 눈금당 이송량 Feed per graduation of handwheel	mm	0.001, 0.01, 0.025	0.001, 0.01, 0.025	0.001, 0.01, 0.025	0.001, 0.01, 0.025	0.001, 0.01, 0.025	0.001, 0.01, 0.025
Grinding Wheel	외경 × 폭 × 내경 Diameter × Width × Bore		mm	Ø510 × 50 × Ø127	Ø510 × 50 × Ø127	Ø510 × 50 × Ø127	Ø510 × 50 × Ø127	Ø510 × 50 × Ø127	Ø510 × 50 × Ø127
	회전수 (50Hz/60Hz) Spindle Speed		r.p.m	1000 / 1200	1000 / 1200	1000 / 1200	1000 / 1200	1000 / 1200	1000 / 1200
Motor	스핀들용 Grinding wheel spindle motor		Kw/p	7.5 / 6	15 / 6	15 / 6	15 / 6	15 / 6	15 / 6
	유압펌프용 Hydraulic pump motor		Kw/p	5.5 / 6	5.5 / 6	5.5 / 6	7.5 / 6	5.5 / 6	7.5 / 6
기계중량 (약) Net weight of machine (about)		kg	7400	12300	14600	16300	15300	15900	

외 형 도 Dimension

■ YGS-1360SCZ, 1670SCZ, 2280SCZ, 3080SCZ, 2290SCZ, 2590SCZ

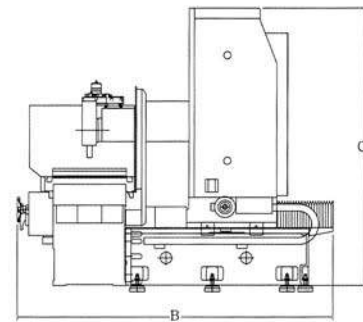
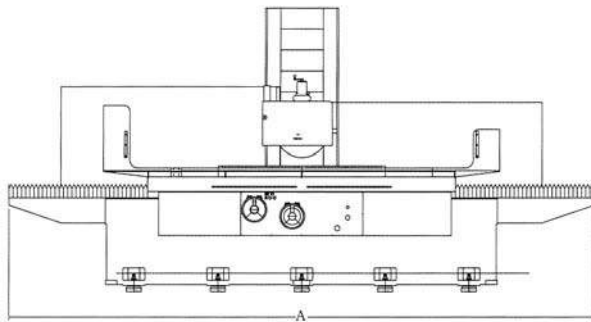

구 분	A	B	C
YGS-1360SCZ	5210	2570	2245
YGS-1670SCZ	5580	3020	2660
YGS-2280SCZ	6790	3200	2690

구 분	A	B	C
YGS-3080SCZ	9120	3200	2690
YGS-2290SCZ	6790	3350	2690
YGS-2590SCZ	7630	3350	2690

GROUP IV 문형 평면 연삭기 시리즈

DOUBLE COLUMN TYPE SURFACE GRINDING MACHINE

특징 Main Feature

대형 평면 연삭에 적합한 강력한 문형 (Double Column) Type 평면 연삭기

- 단일 Column 방식으로는 연삭이 어려운 Work 폭 900mm 이상의 대형 가공품 연삭에 적합한 고강성 구조로 설계·제작

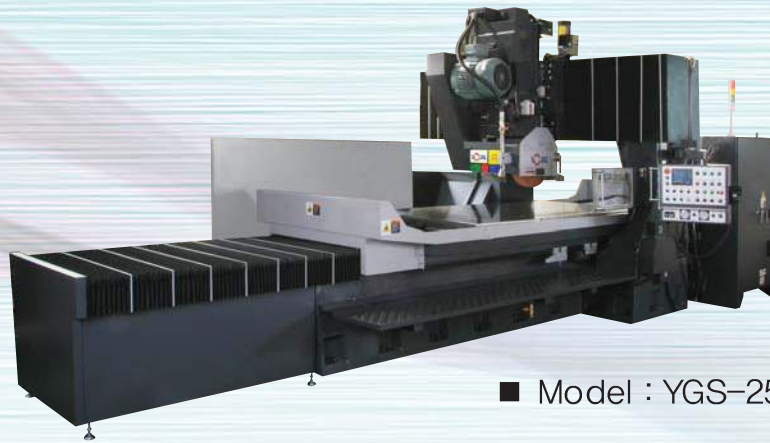

■ Model : YGS-2512SCYZ

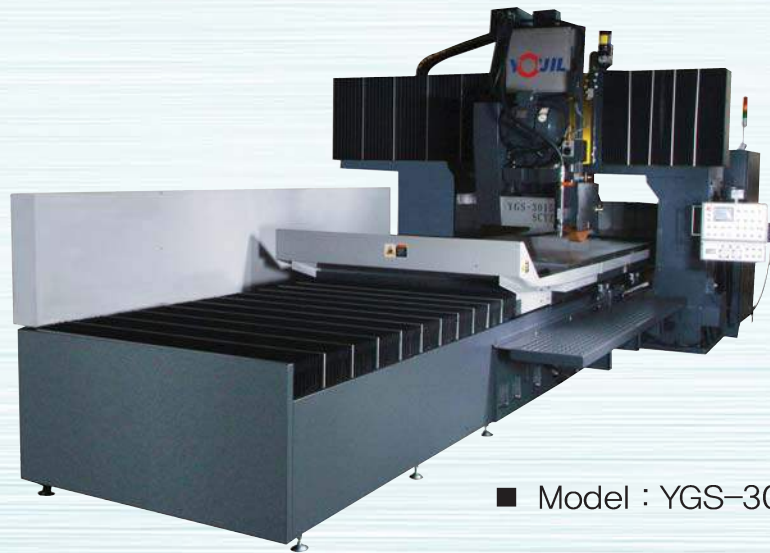

■ Model : YGS-3015SCYZ

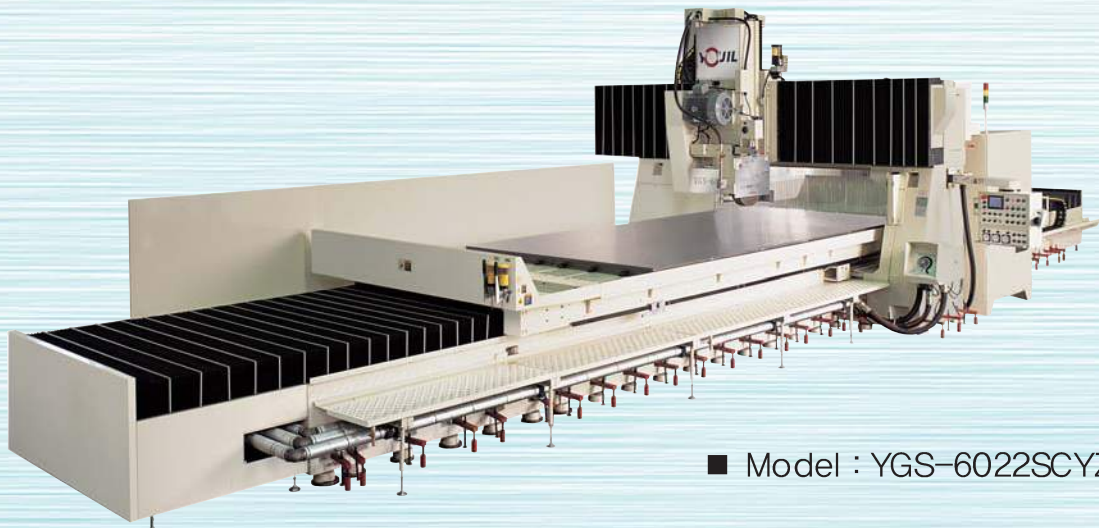

■ Model : YGS-6022SCYZ

제 원 Specification

항목 Item		단위 Unit	YGS-2512SCYZ	YGS-3015SCYZ	YGS-3018SCYZ	YGS-4320SCYZ	YGS-6022SCYZ	
Capacity	테이블 면적 (길이 × 폭) Table size	mm	2550 × 1200	3050 × 1500	3050 × 1800	4150 × 2000	6050 × 2200	
	표준척의 크기 (길이 × 폭) Electric magnetic chuck size	mm	2500 × 1200	3000 × 1500	3000 × 1800	4000 × 2000	6000 × 2200	
	테이블 상면에서 스톨 중심까지의 거리 Max. distance between table surface and grinding wheel center	mm	0 ~ 830	0 ~ 830	0 ~ 830	0 ~ 830	0 ~ 830	
	최대 통과 폭 Distance between columns	mm	1450	1750	2250	2750	2750	
좌우 이동 속도 (평균) Traverse speed range		m/min	4 ~ 30	4 ~ 30	4 ~ 30	4 ~ 30	4 ~ 30	
Table	전후 수동이송 Manual Cross Feed	핸들 회전당 이송량 Feed per revolution of handwheel	mm	0.1, 1.0, 10	0.1, 1.0, 10	0.1, 1.0, 10	0.1, 1.0, 10	0.1, 1.0, 10
		다이얼 눈금당 이송량 Feed per graduation of handwheel	mm	0.001, 0.01, 0.1	0.001, 0.01, 0.1	0.001, 0.01, 0.1	0.001, 0.01, 0.1	0.001, 0.01, 0.1
	전후 자동이송 Automatic Cross Feed	간헐이송 (Step) Intermittent feed	mm	1 ~ 99	1 ~ 99	1 ~ 99	1 ~ 99	1 ~ 99
		연속이동 Continuous feed	m/min	0 ~ 3	0 ~ 3	0 ~ 3	0 ~ 3	0 ~ 3
Grinding head	자동 첩입 이송량 Automatic Down Feed		mm	0.001 ~ 0.03	0.001 ~ 0.03	0.001 ~ 0.03	0.001 ~ 0.03	0.001 ~ 0.03
	수동 첩입 이송량 Manual down feed	핸들 회전당 이송량 Feed per revolution of handwheel	mm	0.1, 1.0, 2.5	0.1, 1.0, 2.5	0.1, 1.0, 2.5	0.1, 1.0, 2.5	0.1, 1.0, 2.5
		다이얼 눈금당 이송량 Feed per graduation of handwheel	mm	0.001, 0.01, 0.025	0.001, 0.01, 0.025	0.001, 0.01, 0.025	0.001, 0.01, 0.025	0.001, 0.01, 0.025
Grinding Wheel	외경 × 폭 × 내경 Diameter × Width × Bore		mm	Ø510 × 100 × Ø203.2	Ø510 × 100 × Ø203.2	Ø510 × 100 × Ø203.2	Ø510 × 100 × Ø203.2	Ø510 × 100 × Ø203.2
	회전수 (50Hz / 60Hz) Spindle Speed		r.p.m	980 / 1200	980 / 1200	980 / 1200	980 / 1200	980 / 1200
Mtr	스핀들용 Grinding wheel spindle motor		Kw/p	15 / 6	15 / 6	15 / 6	15 / 6	15 / 6
	유압펌프용 Hydraulic pump motor		kg	11 / 6	15 / 6	22 / 6	22 / 6	22 / 6
기계중량 (약) Net weight of machine (about)			22,000	32,000	33,500	45,000	65,000	

외 형 도 Dimension

■ YGS-2512SCYZ, 3015SCYZ, 3018SCYZ, 4320SCYZ, 6022SCYZ

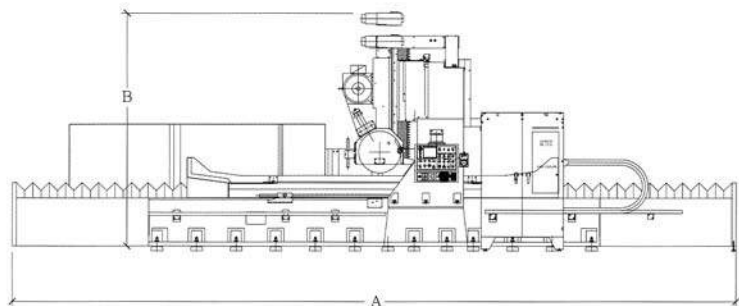
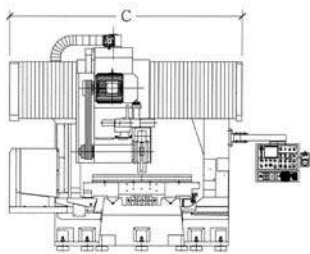

구 분	A	B	C
YGS-2512SCYZ	8500	2965	3000
YGS-3015SCYZ	10935	3915	3650
YGS-3018SCYZ	10935	3915	3650

구 분	A	B	C
YGS-4320SCYZ	12580	4620	3650
YGS-6022SCYZ	16500	4620	3650

GROUP V CNC 연삭기 시리즈

COMPUTERIZED NUMERICAL CONTROL SURFACE GRINDING MACHINE

특징 Main Feature

다양한 드레싱 프로그램과 연삭패턴을 적용하여 일반 평면연삭에서 작업하기 어려운 형상의 연삭에 쉽게 대응할 수 있도록 프로그램 되어 있습니다.

- 다양한 연삭형상에 대응하기 위한 세부적인 조절이 가능한 드레싱 프로그램
- 다양한 연삭패턴을 통한 생산성 향상 및 복합형상가공
- 프로그램 조정으로 양산을 위한 전용기로의 전용성 강화기능



■ Model : YGS-96CNC



■ Model : YGS-52CNC



■ Controller

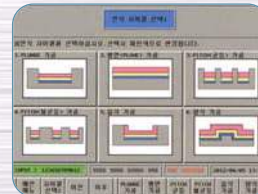

■ Various Grinding Program

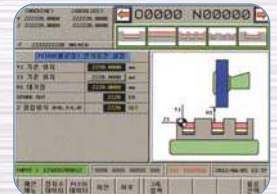

■ Detailed Grinding Work Setting

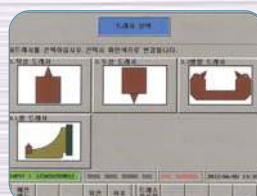

■ Various Dresser System



■ Flexible Dressing Program

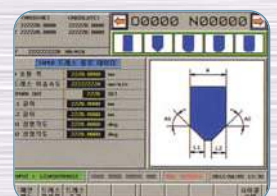

■ Detailed Dressing Data Setting

Servo Control 평면 연삭기 시리즈

SERVO CONTROL SADDLE TYPE SURFACE GRINDING MACHINE
SERVO CONTROL COLUMN TYPE SURFACE GRINDING MACHINE

특징 Main Feature

Servo System

(1축 : Z / 2축 : Y, Z)을 채용하여
고정도 · 고능률 전자동 Cycle 연삭을 실현

- User의 요구에 의한 다양한 Servo 제어 방식의 연삭기 제작 가능
 - 범용 연삭기보다 간편한 조작방식
 - 고정도의 미세연삭 가능
 - 황삭 절입량 0.001~0.03mm의 12단계(선택 설정 제어)
 - 사상 절입량 0.001~0.01mm의 9단계(선택 설정 제어)

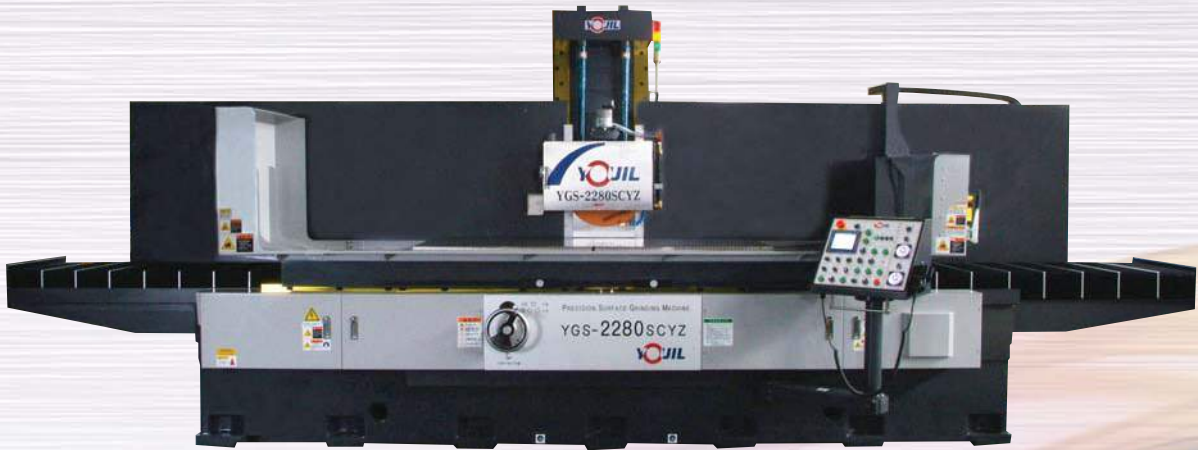

■ Model : YGS-2280SCYZ

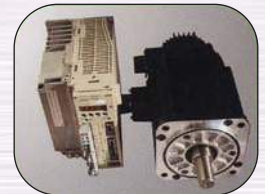
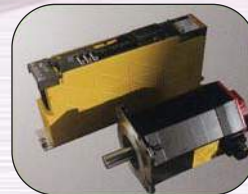

제원 Specification

SC SYSTEM		Servo System (1축 : Z, 2축 : Y, Z)를 채용하여 고정도 고능률 전자동 Cycle 연삭을 실현				
항목 Item	단위 Unit	Type				
		Saddle type	Column type	Double Column type		
모델 Model	-	YGS-52SCZ/SCYZ YGS-63SCZ/SCYZ YGS-65SCZ/SCYZ YGS-96SCZ/SCYZ YGS-116SCZ/SCYZ YGS-137SCZ/SCYZ	YGS-1360SCYZ YGS-1670SCYZ YGS-2280SCYZ YGS-3080SCYZ YGS-2290SCYZ YGS-2590SCYZ	YGS-2512SCYZ YGS-3015SCYZ YGS-3018SCYZ YGS-4320SCYZ YGS-6022SCYZ		
특징	전후 수동이송 Manual cross feed	핸들 1회전당 이송량 Feed: per revolution of hand wheel	mm	5 / 0.1(×1), 1(×10), 10(×100)	0.1(×1), 1(×10), 10(×100)	0.1(×1), 1(×10), 10(×100)
	전후 자동이송 Automatic cross feed	다이얼 한금당 이송량 Feed: per graduation of hand wheel	mm	0.02 / 0.001(×1), 0.01(×10), 0.1(×100)	0.001(×1), 0.01(×10), 0.1(×100)	0.001(×1), 0.01(×10), 0.1(×100)
		간헐이송 (Step) Intermittent feed	mm	0.5~20 / 1~50	1~50	1~99
	자동 절입 이송량 Automatic down feed	연속이송 Continuous feed	m/min	0.1~1.0 / 0~4	0~4	0~3
		수동 절입 이송량 Manual down feed	핸들 1회전당 이송량 Feed: per revolution of hand wheel	mm	0.001, 0.002, 0.003, 0.004, 0.005, 0.006, 0.008, 0.010, 0.015, 0.020, 0.025, 0.030	
수동 절입 이송량 Manual down feed	다이얼 한금당 이송량 Feed: per graduation of hand wheel	mm	0.1(×1), 1(×10), 25(×25)			
		mm	0.001(×1), 0.01(×10), 0.025(×100)			

Accessories

표준부속품 / Standard Accessories

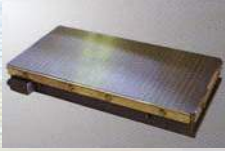

1. 전자척 Magnet chuck



2. 연마석 Grinding wheel



3. 연마석 플렌지
Grinding wheel flange



4. 플렌지 리무브
Flange Remove



5. 탁상식 슛돌드레서
Diamond dresser and Holder



6. 두상 드레싱 장치
Upper dresser



7. 밸런싱 아바
Balancing arbor



8. 필요공구 및 공구상자
Tool sets and Box



9. 레벨링 볼트 및 플레이트
Leveling bolt and plate



10. 작업등 Working light



11. 자동탈자장치
Automatic demagnetizer



12. 방수 카바
Waterless cover



13. 상하급이송장치
Rapid up down feed
equipment
(YGS-52A 이상 적용, 상향/중 제외)



14. 와이어 Wire
(YGS-52B, 46B 적용)

특별부속품 / Optional Accessories



1. 흡진주수 장치
Coolant and Dust
absorber system



2. 비란상장치
Balancing stand



3. R-드레서
Redirs-Dresser



4. S-드레서
Sine-Dresser



5. 연마바이스-3"
Grinding vise-3"



6. 상하·전후 디지털카운터
V.H Digital counter



7. 사인바이스
Sine vise

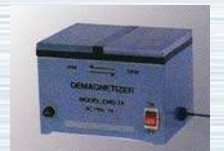

8. 제품탈자장치
Demagnetizer



9. 자동 페이퍼 필터 장치
Automatic paper filter
system



10. 수동식 페이퍼 필터 장치
Manual paper filter system



11. 인버터 Inverter



12. 오일쿨러 Oil Cooler

Working Area 가공범위도

정밀성형연삭기 Precision Forming Surface Grinding Machine

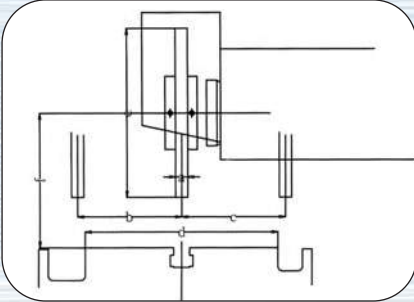

구 분	a	b	c	d	e	f
YGS-46B	19	90	100	154	180	465
YGS-52B	19	120	120	204	180	540
YGS-46	19	90	100	154	180	465
YGS-46XA	19	90	100	154	180	465
YGS-50A	19	90	90	154	180	465

자동평면연삭기 Saddle Type Surface Grinding Machine

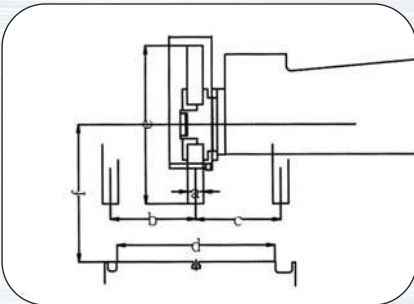

구 분	a	b	c	d	e	f
YGS-52A	19	110	110	200	205	500
YGS-63A	38	185	185	300	305	522
YGS-65A	38	262	263	500	305	697
YGS-96A	38	262	263	500	305	697
YGS-116A	50	270	270	500	305	697
YGS-137A	50	320	320	500	510	845

대형자동평면연삭기 Column Type Surface Grinding Machine

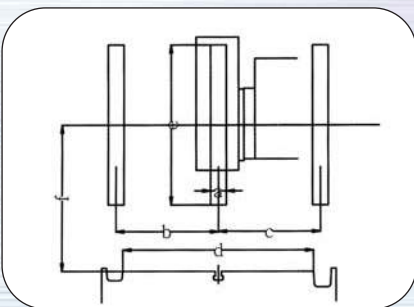

구 분	a	b	c	d	e	f
YGS-1360SCZ	50	315	315	600	510	845
YGS-1670SCZ	50	365	365	700	510	950
YGS-2280SCZ	50	415	415	800	510	950
YGS-3080SCZ	50	415	415	800	510	950
YGS-2290SCZ	50	465	465	900	510	950
YGS-2590SCZ	50	465	465	900	510	950

문형평면연삭기 Double Column Type Surface Grinding Machine

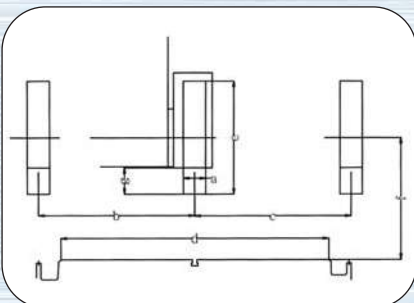

구 분	a	b	c	d	e	f	g
YGS-2512SCYZ	100	700	700	1200	510	830	120
YGS-30155SCYZ	100	900	900	1500	510	830	120
YGS-3018SCYZ	100	1125	1125	1800	510	830	120
YGS-4320SCYZ	100	1250	1250	2000	510	830	120
YGS-6022SCYZ	100	1250	1250	2200	510	830	120

YOUJIL 유일연삭기주식회사
YOUIL GRINDING MACHINE CO.,LTD.

영업 본부 : 서울시 금천구 시흥대로 97, B 지원상가 207호(시흥동, 시흥유통상가)

TEL : 대표 (02)802-3958 (802-3959, 804-2743)

FAX : (02) 804-2744 A/S센터 : (02) 802-3993~4

영남사업소 및 A/S센터 : 대구광역시 북구 노곡로 16-1(노곡동)

TEL : (053)355-4032 FAX : (053)355-4033

부산사업소 및 A/S센터 : 부산 사상구 과감로 37(괘법동) 부산산업용품유통상가 9동 202호

TEL : (051)319-0214 FAX : (051)319-0215

호남사업소 : 광주광역시 광산구 하남산단 6번로 46-20(오선동)

TEL : (062)951-4550 FAX : (062)951-4551

공 장 : 광주광역시 광산구 손재로 368-44(장덕동)

TEL : (062)952-6111~4 FAX : (062)952-6115

SEOUL OFFICE

SIHEUNG YUTONGSANGGA B DONG 207

97 SIHEUNG-DAERO, GEUMCHEON-GU, SEOUL, KOREA.

TEL : (82-2)802-3958 (802-3959, 802-3993~4)

FAX : (82-2)804-2744

FACTORY

368-44, SONJAE-RO, GWANGSAN-GU GWANGJU, KOREA

TEL(82-62)952-6111~4 FAX(82-62)952-6115

<http://www.youilmc.com> E-mail : ygs2080@nate.com