



CHUCK CONTROLLER

HOLDING is the leading brand of chuck controller manufacturer in Taiwan. Over the last 40 years, HOLDING chuck controllers have been widely adopted and become a standard accessory of Taiwanese surface grinders and chucks. The controllers are robust, stable and durable. Universal controllers for all types of electromagnetic chucks.

HD-235A (5A/10A)



Features

- Interior type
- The current capacity : 5A or 10A
- Demag. Time: 6~15 sec.
- The output charge voltage of the chuck can be adjusted precisely.
- The output charge voltage is indicated with an LED display.
- With HD-AD20-CABLE control cable, easy to install in the distribution box.
- Optional function: CSC (Chuck Safety Control).

General Specs

MODEL	HD-235A
TYPE	Interior
CURRENT	5A / 10A
DIMENSION (W x L x H)	205 x 147 x 90 mm
WEIGHT	2 KG

Input / Output Voltage Options

Input	Output
AC 110V (default)	DC 0~90V (default)
AC 100V	DC 0~80V
AC 140V	DC 0~110V

Circuit Diagram

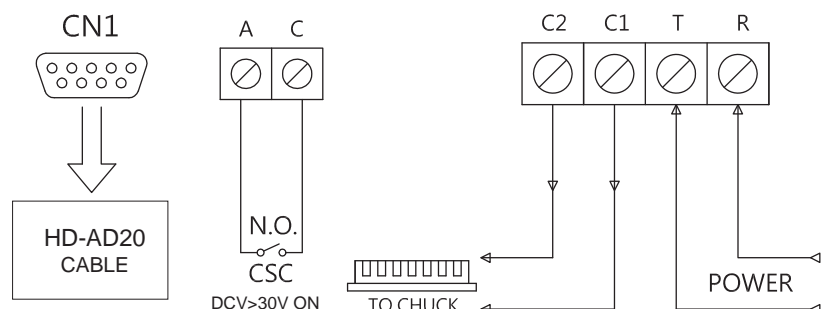
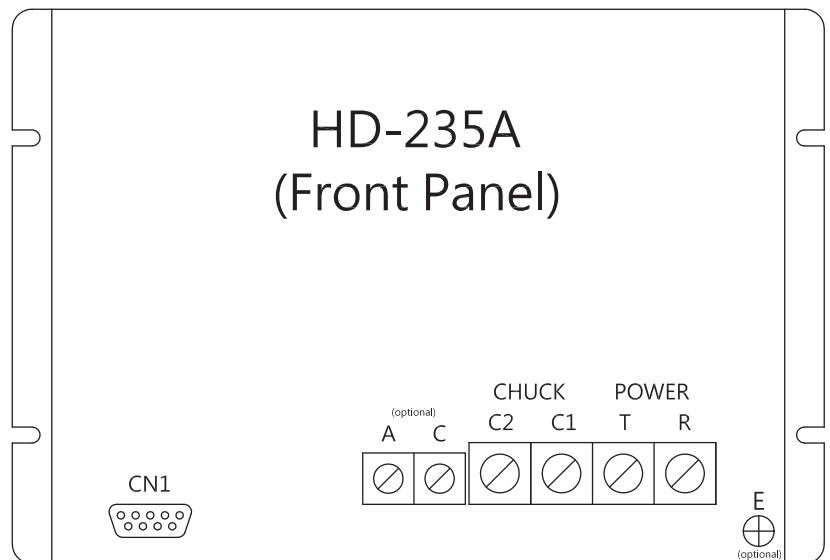

*Please refer to the attachment for detailed circuit wiring methods from CN1 to HD-AD20-cable.