

Venturi Tube

HVT Series



ISO 9001



ISO 14001

ASME



www.hitrol.com



Always The Best Solution
HITROL CO., LTD.

Venturi Tube

Model : HVT Series

Introduction

HVT Series has been designed to gain the best performance for flow measurement on the basis of rich experience through the designing of several differential pressure flow meters in compliance with the standard of ISO 5167.

A lot of manufacturers are producing the venturi tube but HITROL is continuously supplying this flow element with high quality on the basis of the continuous R&D and technical innovation through the improvement of the technic for flow measurement.

HVT Series is a venturi tube flow element which measures a differential pressure occurred by a reducing of cross sectional area between inlet and throat section and it secures a stable discharge coefficient.



Calibration

■ Discharge Coefficient (C)

HVT Series can obtain an accuracy of $\pm 0.5\%$ ~ $\pm 1.0\%$ by performing of calibration in liquid flow calibration system.

As below graph, the discharge coefficient of flow element can be stably measured at any pipe Reynolds number greater than 75,000.

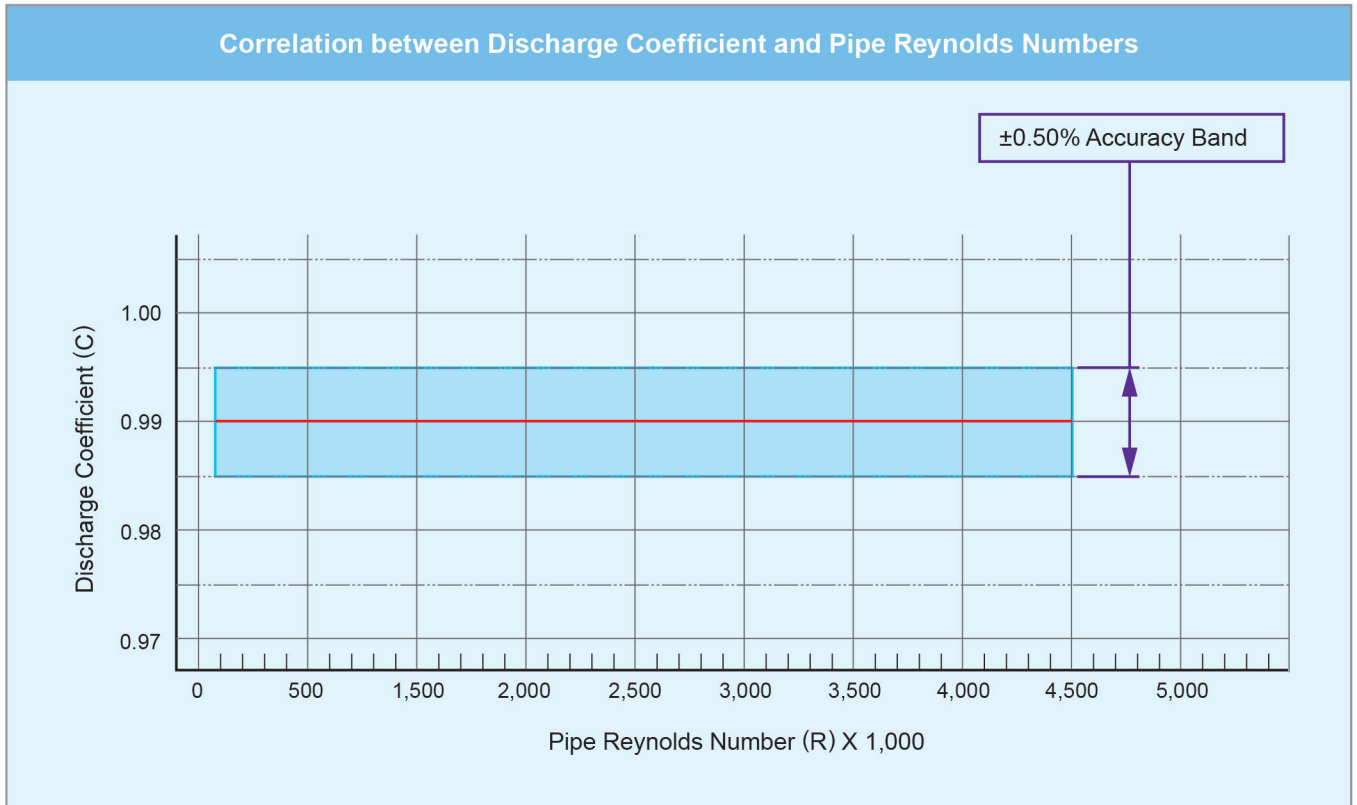

Specification

Operating conditions	Line fluid capability	Clean liquids, Gas, Steam, and Contaminated line fluids
	Temperature Rating	Depends on material of construction
	Pressure Rating	From full vacuum to the limits of materials.
Line Size Capabilities / End Arrangement	Line sizes between 1" through 80" Flange ends, Weld end, Plain, Mechanical joint, or other as required.	
Beta ratio Capability	Custom sized and designed for Beta ratio range between 0.30 through 0.75	
Material	304SS or 316SS Stainless steel, Carbon Steels Monel, Hastelloy or other as required.	
Pipe Reynolds Number R_D	Must be greater than 75,000	
Permanent Pressure Loss	Varies from 3.5% to 10% of differential depending on application conditions, beta ratio.	
Accuracy	Between $\pm 0.5\%$ to $\pm 1.0\%$ of full scale.	



Design and Manufacturing Standard

Hitrol is designing and manufacturing the Venturi Tube in full compliance with standards of ISO 5167 and ASME MFC-3.

FABRICATED VENTURI TYPE
AVAILABLE IN SIZE BETWEEN 3" AND 144"

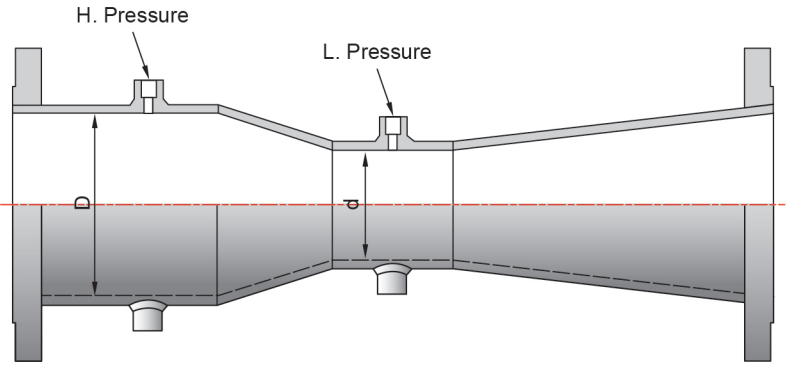

MACHINED SCREW TYPE
AVAILABLE IN SIZE 4" AND SMALLER

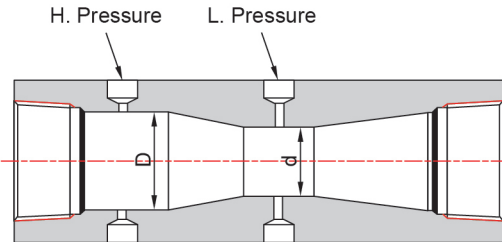

$$\text{Beta} = d/D$$

MACHINED WELD-ON TYPE
AVAILABLE IN SIZE 6" AND SMALLER

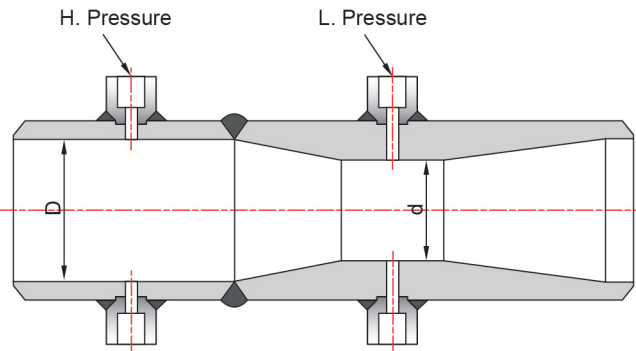

$$\text{Beta} = d/D$$

MACHINED FLANGE TYPE
AVAILABLE IN SIZE 6" AND SMALLER

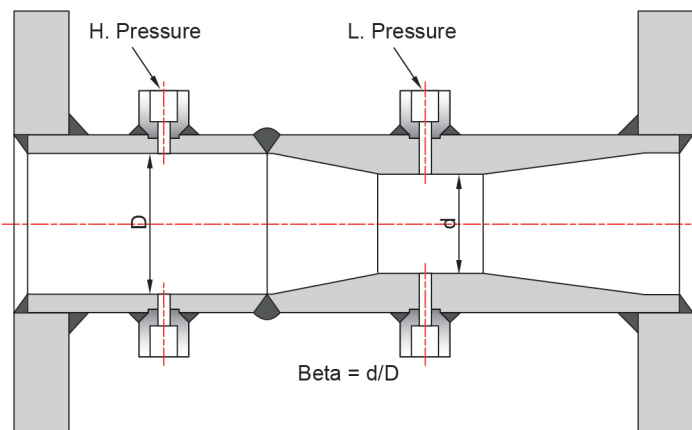

$$\text{Beta} = d/D$$

No Effect by Downstream Disturbers

HVT Series is not affected on the basic measurement accuracy by any disturbers such as elbow, tee's, valves, increasers and reducer that are installed on downstream. However, measurement accuracy of other flow elements is more affected by these disturbers on downstream than HVT Series.

Effect by Upstream Disturbers

Effect on the measurement accuracy by various upstream disturbers is well known and is as below graph.

- General effect by disturbers.

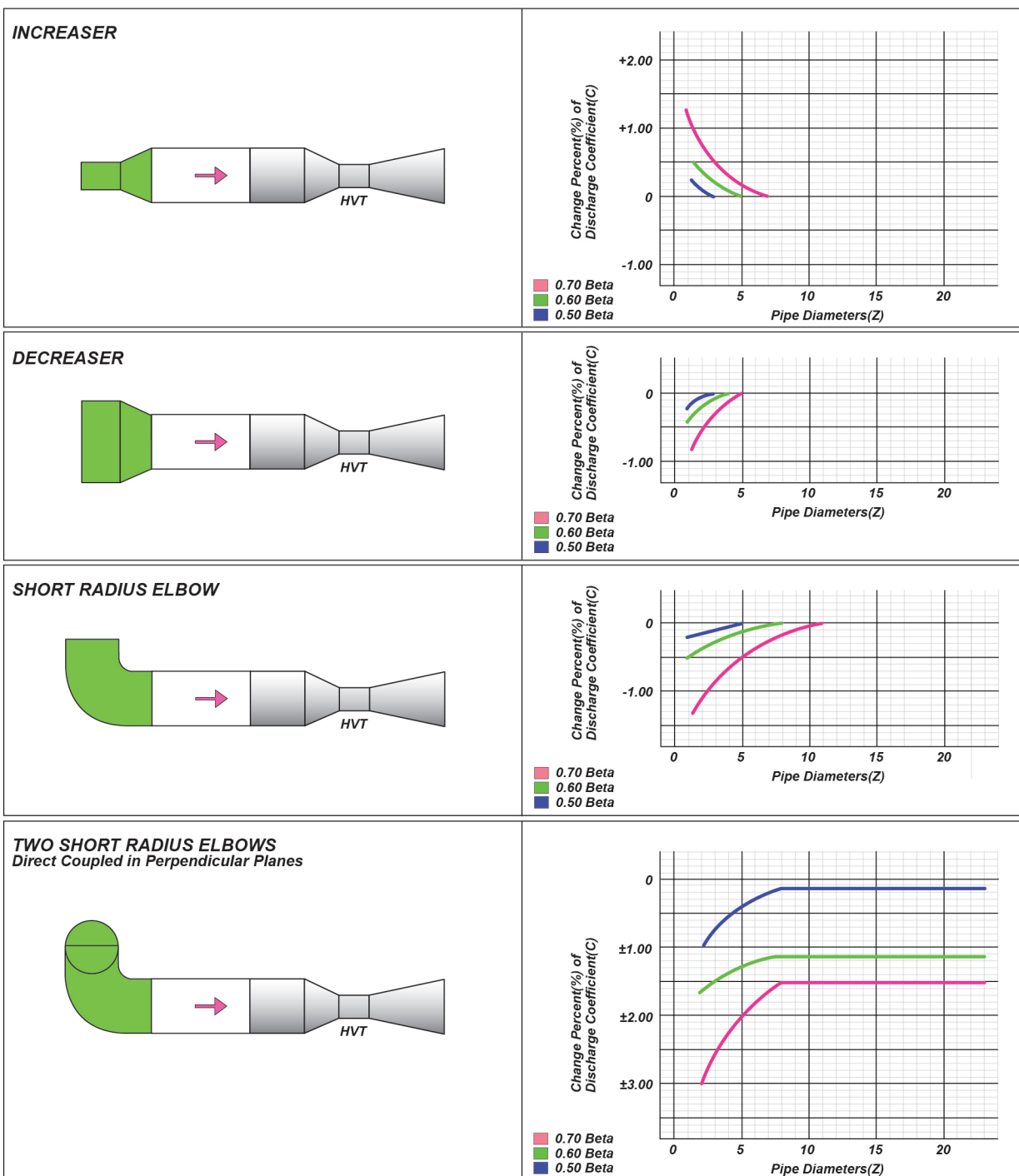

ISO 5167

Required Straight Pipe Length

Diameter Ratio β	Single 90° bend	Two or more 90° bends in the same plane	Reducer 3D to D over a length of 3.5D	Expander 0.75D over a length of D	Full bore ball or gate valve fully open
0.30	8	8	2.5	2.5	2.5
0.35	8	8	2.5	2.5	2.5
0.40	8	8	2.5	2.5	2.5
0.50	9	10	5.5	2.5	3.5
0.60	10	10	8.5	3.5	4.5
0.70	14	18	10.5	5.5	5.5
0.75	16	22	11.5	6.5	5.5

■ values expressed as multiples of internal diameter, D

Pressure Taps Orientation

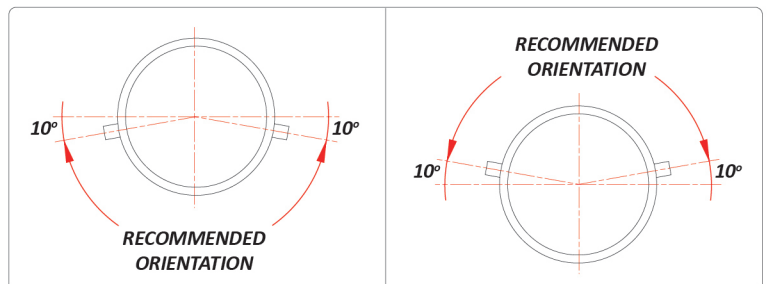
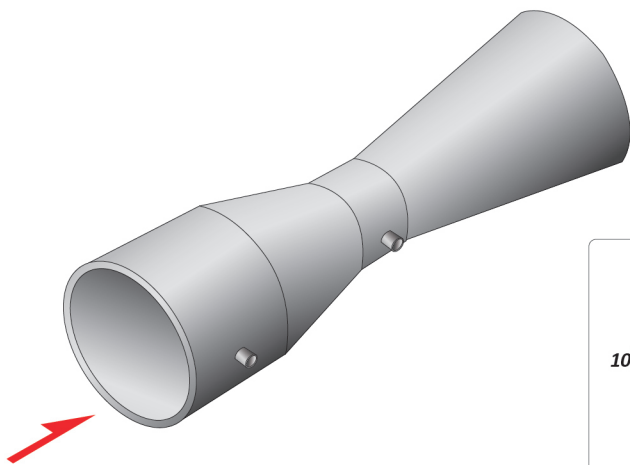

LIQUIDS

STEAM & GAS

Dimension Table for Water Measurement (For Reference)

The following data is for reference only. HVT Series can measure flow rate of gas, liquid and steam in a wide range of pipe line size and Beta Ratio. Contact HITROL for more information.

Line Size in inches millimeters D	Beta Ratio b	Throat Dia. d	Laying Length inches L	Laying Length millimeters L	Meter Outlet Diameter Inches DRC	Water Flow Rate at 68°F Gallons per Minute GPM	Water Flow Rate at 20°C Liters per Minute LPM	Pipe Reynolds Number Number x 1000 = RD	Head Loss Inches of Water HL	Head Loss Millimeters of Waer HL
3.00 76.20	0.05	1.50	7.25	184.15	2.27	130.38	493.53	123	10.40	264.41
	0.60	1.80	6.70	170.18	2.46	194.85	737.57	183	8.82	224.03
	0.70	2.10	6.05	153.67	2.63	283.84	1,074.42	267	6.73	170.94
4.00 101.60	0.05	2.00	13.67	347.22	3.02	231.78	877.36	163	10.05	255.27
	0.60	2.40	12.94	328.68	3.28	346.39	1,311.19	244	8.52	216.41
	0.70	2.80	12.07	306.58	3.51	504.59	1,910.03	355	6.50	165.10
5.00 127.00	0.05	2.50	16.09	408.69	3.78	362.16	1,370.89	204	9.79	248.67
	0.60	3.00	15.17	385.32	4.09	541.24	2,048.76	305	8.29	210.56
	0.70	3.50	14.09	357.89	4.39	788.43	2,984.45	444	6.33	160.78
6.00 152.40	0.05	3.00	20.50	520.70	4.53	521.51	1,974.08	245	9.58	243.33
	0.60	3.60	19.41	493.01	4.91	779.38	2,950.19	366	8.11	205.99
	0.70	4.20	18.11	459.99	5.27	1,135.34	4,297.61	533	6.19	157.23
8.00 203.20	0.05	4.00	25.34	643.64	6.04	927.13	3,506.47	326	9.25	234.95
	0.60	4.80	23.88	606.55	6.55	1,385.57	5,244.81	488	7.84	199.14
	0.70	5.60	22.15	562.61	7.02	2,018.36	7,640.11	710	5.98	151.89
10.00 254.00	0.05	5.00	30.17	766.32	7.55	1,448.64	5,483.55	408	9.01	228.85
	0.60	6.00	28.35	720.09	8.19	2,164.96	8,195.04	610	7.63	193.80
	0.70	7.00	26.18	664.97	8.78	3,153.73	11,937.83	888	5.82	147.83
12.00 304.80	0.05	6.00	35.00	889.00	9.06	2,086.04	7,896.30	490	8.81	223.77
	0.60	7.20	32.82	833.63	9.83	3,117.54	11,800.84	732	7.47	189.74
	0.70	8.40	30.22	767.59	10.54	4,541.37	17,190.47	1,066	5.70	144.78
14.00 355.60	0.05	7.00	39.84	1,011.94	10.57	2,839.34	10,747.77	571	8.65	219.71
	0.60	8.40	37.29	947.17	11.46	4,243.32	16,062.26	854	7.33	186.18
	0.70	9.80	34.26	870.20	12.29	6,181.31	23,398.15	1,243	5.59	141.97
16.00 406.40	0.05	8.00	44.68	1,134.87	12.07	3,708.52	14,037.88	653	8.51	216.15
	0.60	9.60	41.75	1,060.45	13.10	5,542.29	20,979.26	975	7.21	183.13
	0.70	11.20	38.30	972.82	14.05	8,073.54	30,560.82	1,421	5.50	139.70
18.00 457.20	0.05	9.00	49.51	1,257.55	13.59	4,693.60	17,766.71	734	8.39	213.11
	0.60	10.80	46.22	1,173.99	14.74	7,014.46	26,551.88	1,097	7.11	180.59
	0.70	12.60	42.33	1,075.18	15.80	10,218.08	38,678.56	1,599	5.42	137.67
20.00 508.00	0.05	10.00	54.35	1,380.49	15.10	5,794.56	21,934.18	816	8.29	210.57
	0.60	12.00	50.69	1,287.53	16.38	8,659.83	32,780.11	1,219	7.02	178.31
	0.70	14.00	46.37	1,177.80	17.56	12,614.91	47,751.29	1,776	5.36	136.14
24.00 609.60	0.50	12.00	64.02	1,626.11	18.12	8,344.17	31,585.24	979	8.11	205.99
	0.60	14.00	59.63	1,514.60	19.65	12,470.16	47,203.37	1,463	6.87	174.50
	0.70	16.80	54.44	1,382.78	21.07	18,165.47	68,761.86	2,131	5.24	133.10

■ The data contained in this chart is based on reference values of 68°F(20°C)Water producing 100inches (2540mm) of differential pressure.

Dimension Table for Water Measurement (For Reference)

Line Size in inches millimeters D	Beta Ratio b	Throat Dia. d	Laying Length inches L	Laying Length millimeters L	Meter Outlet Diameter Inches DRC	Water Flow Rate at 68°F Gallons per Minute GPM	Water Flow Rate at 20°C Liters per Minute LPM	Pipe Reynolds Number Number x 1000 = RD	Head Loss Inches of Water HL	Head Loss Millimeters of Waer HL
30.00 762.00	0.50	15.00	80.52	2,045.21	22.65	13,037.77	49,351.95	1,224	7.89	200.41
	0.60	18.00	75.04	1,906.02	24.56	19,484.62	73,755.25	1,829	6.69	169.93
	0.70	21.00	68.55	1,741.17	26.34	28,383.55	107,440.42	2,664	5.10	129.54
36.00 914.40	0.50	18.00	95.03	2,413.76	27.18	18,744.39	71,066.81	1,469	7.72	196.09
	0.60	21.60	88.45	2,246.63	29.48	28,057.85	106,207.54	2,195	6.54	166.12
	0.70	25.20	80.66	2,048.76	31.62	40,872.31	154,714.19	3,197	4.99	126.75
42.00 1066.80	0.50	21.00	111.53	2,832.86	31.71	25,554.03	96,729.82	1,713	7.58	192.53
	0.60	25.20	103.86	2,638.04	34.39	38,189.85	144,560.26	2,561	6.42	163.07
	0.70	29.40	94.77	2,407.16	36.88	55,631.76	210,583.22	3,730	4.90	124.46
48.00 1219.20	0.50	24.00	126.03	3,201.16	36.24	33,376.69	126,340.98	1,958	7.46	189.48
	0.60	28.80	117.26	2,978.40	39.30	49,880.63	188,813.44	2,926	6.32	160.53
	0.70	33.60	106.89	2,715.00	42.15	72,661.89	275,047.47	4,263	4.82	122.43
54.00 1371.60	0.50	27.00	140.54	3,569.72	40.77	42,242.37	159,900.29	2,203	7.36	186.94
	0.60	32.40	130.67	3,319.02	44.21	63,130.17	238,967.00	3,292	6.23	158.24
	0.70	37.80	119.00	3,022.60	47.41	91,962.71	348,106.98	4,796	4.75	120.65
60.00 1524.00	0.50	30.00	157.04	3,988.82	45.30	52,151.07	197,407.75	2,448	7.26	184.40
	0.60	36.00	146.08	3,710.43	49.13	77,938.48	295,020.98	3,658	6.16	156.46
	0.70	42.00	133.11	3,380.99	52.68	113,534.21	429,761.70	5,329	4.69	119.13
66.00 1676.40	0.50	33.00	171.55	4,357.37	49.83	63,102.80	238,863.40	2,692	7.18	182.37
	0.60	39.60	159.49	4,051.05	54.04	94,305.56	356,975.38	4,024	6.09	154.69
	0.70	46.20	145.22	3,688.59	57.95	137,376.39	520,011.65	5,862	4.64	117.86
72.00 1828.80	0.50	36.00	188.05	4,776.47	54.36	75,097.54	284,267.15	2,937	7.11	180.59
	0.60	43.20	174.90	4,442.46	58.95	112,231.41	424,830.21	4,390	6.02	152.91
	0.70	50.40	159.33	4,046.98	63.22	163,489.26	618,856.84	6,394	4.59	116.59
84.00 2133.60	0.50	42.00	217.06	5,513.32	63.42	102,216.10	386,919.20	3,427	6.98	177.29
	0.60	50.40	201.71	5,123.43	68.78	152,759.42	578,241.12	5,121	5.91	150.11
	0.70	58.80	183.55	4,662.17	73.75	222,527.04	842,332.90	7,460	4.51	114.55
96.00 2438.40	0.50	48.00	248.07	6,300.98	72.48	133,506.74	505,363.84	3,916	6.87	174.50
	0.60	57.60	230.53	5,855.46	78.60	199,522.51	755,253.71	5,853	5.82	147.83
	0.70	67.20	209.77	5,328.16	84.29	290,647.57	1,100,189.93	8,526	4.44	112.78

■ The data contained in this chart is based on reference values of 68°F (20°C) Water producing 100 inches (2540mm) of differential pressure.

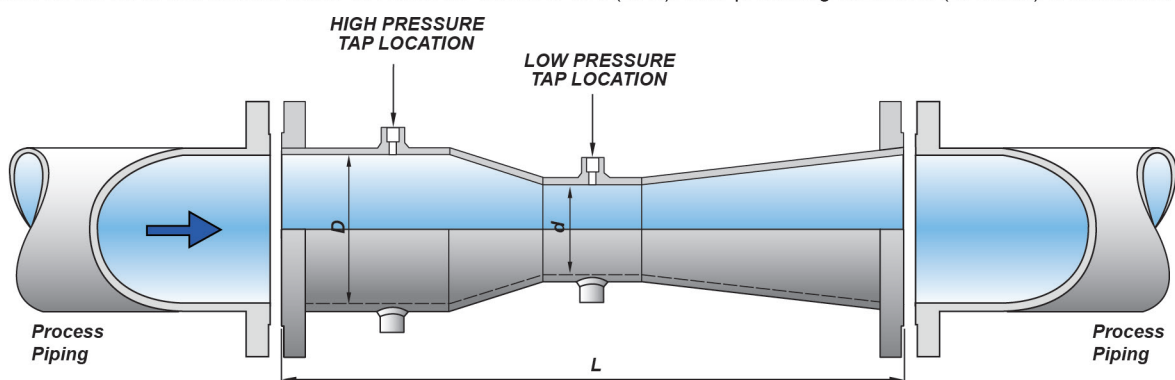



Venturi Tube

In order to calculate a differential pressure and design a Venturi Tube, below information should be informed.

Flow Data	Tag No.			
Fluid Name / Fluid State				
Max. / Nor. Flow Rate (m ³ /hr)				
Max. / Nor. Temperature (°C)				
Max. / Nor. Pressure (psia)				
Pipe Inside Diameter (mm)				
Density at Base (kg/m ³)				
Density at Operating (kg/m ³)				
Operating Viscosity (cP)				