



BYG124-N8

12" BASS GUITAR WOOFER

NEODYMIUM MAGNET



- 12 inch Bass Guitar Woofer
- 4.0inch Voice coil
- 800 Watt Program Power handling
- 98dB/ SPL Sensivity
- Solid low-end and tight mid-high's

GENERAL SPECIFICATIONS

Nominal diameter	mm(in)	300(12)
Nominal impedance	Ω	8
Minimum impedance	Ω	6.7
Program power	W	800
AES Power rating	W	1600
Sensitivity (SPL)	dB	98
Frequency range	Hz	50-1500
Voice coil diameter	mm (in)	100(4)
Chassis material	Steel	
Magnet material	Neodymium	
Magnet dimension (OD x ID x h)	mm (in)	98* *9
Coil material	CCAW	
Former material	Glass fiber	
Diaphragm material	Water Proof Treated Paper	
Diaphragm/Dust cap treatment	Water Proof	
Surround material	Polycotton	
X max	mm (in)	8.75(0.34)
X mech (Peak)	mm (in)	18(0.71)
Gap height	mm (in)	15(0.59)
Voice coil winding height	mm (in)	25(0.98)

FREQUENCY RESPONSE



DIMENSIONS mm (in.)

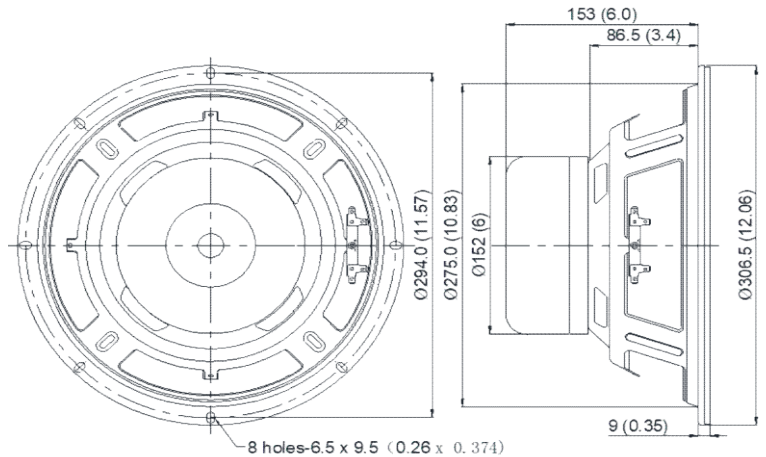

SMALL SIGNAL PARAMETERS

DC Resistance	Re	Ω	5.5
Resonance frequency	Fs	Hz	45
Moving mass	Mms	g(oz)	95(3.35)
Compliance	Cms	mm/N	0.132
Force factor	BxL	T'm	25
Mechanical Q-Factor	Qms	-	10.91
Electrical Q-Factor	Qes	-	0.23
Total Q-Factor	Qts	-	0.225
Equivalent air volume	Vas	l(ft3)	51.16(1.81)
Inductance of voice cile	Le	mH	1.43
Diaphragm area	Sd	cm2 (in2)	523(81.1)
Reference efficiency	no	%	1.94

SHIPPING INFORMATION

Net weight	Kg (lb)
Out carton size (W x D x H)	mm x mm x mm (in x in x in)
Out carton weight	Kg (lb)

www.bhacoustic.com/www.bhacoustel.com