

## Model DSCS Series

Compression & Tension  
Low Profile Load Cell (200 ~ 1000kg)

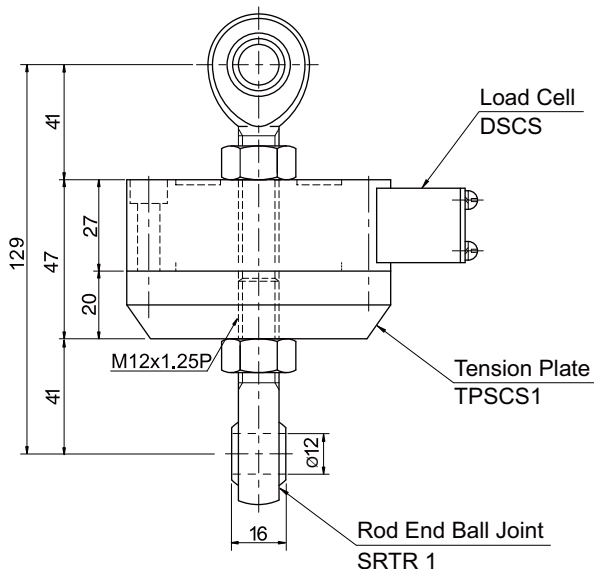
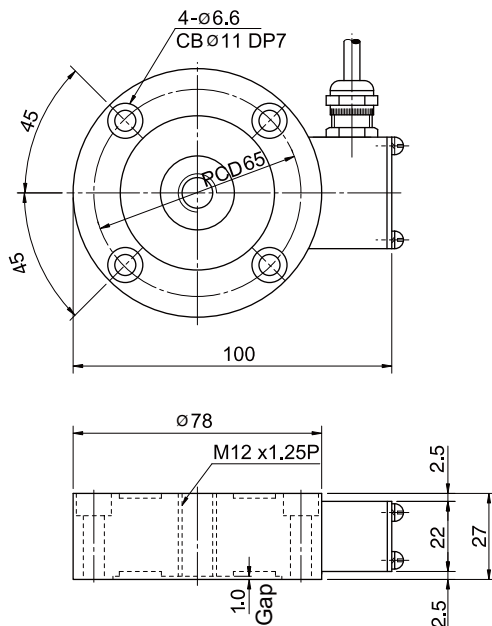
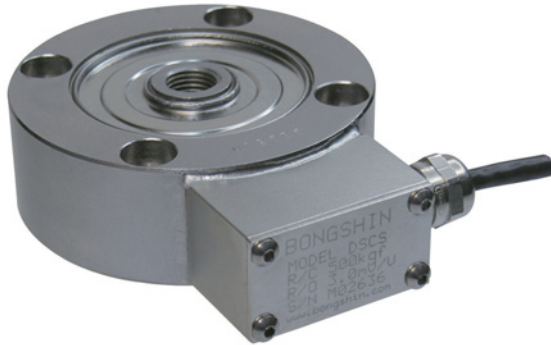

The model DSCS is a low profile compression & tension pancake type load cell. All units are machined from a solid billet of stainless steel and sealed with welded diaphragms.

- 17-4PH Stainless steel construction for high accuracy and corrosion resistance
- Hermetically sealed
- High rated output(3mV/V)

### SPECIFICATIONS

MODEL	DSCS
Rated capacity (R.C.)	200, 500, 1000kg
Rated output(R.O.)	3.0mV/V $\pm$ 0.3%
Non-linearity	$\leq$ 0.05% R.O.
Hysteresis	$\leq$ 0.03% R.O.
Non-repeatability	$\leq$ 0.03% R.O.
Creep error	$\leq$ 0.05% in 20min.
Zero balance	$\leq$ 1% R.O.
Compensated temperature range	-10 ~ 70°C
Operating temperature range	-20 ~ 80°C
Temp. effect on rated output	$\leq$ 0.03% LOAD/10°C
Temp. effect on zero balance	$\leq$ 0.03% R.O./10°C
Terminal input resistance	700 Ohms $\pm$ 10 Ohms
Terminal output resistance	700 Ohms $\pm$ 10 Ohms
Insulation resistance (Min.)	2000 MOhms at 50V DC
Excitation voltage	3~12V(Recommended), 15V(Max.)
Electrical connection	$\phi$ 5mmx3m(22AWG x 4Core Shielded)
Protection class	meets IP 68
Safe overload	150% R.C
Ultimate overload	300% R.C

### ORDERING INFORMATION

**DSCS - 200**  
MODEL DSCS      CAPACITY 200, 500, 1000kg

Weight = 0.9kg

### WIRING INFORMATION

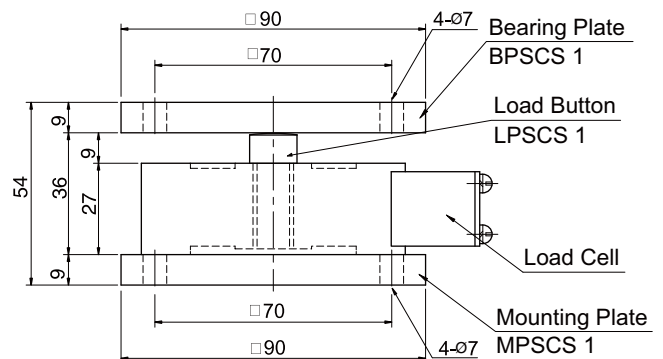
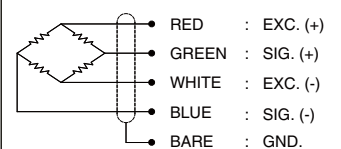

\* Specifications are subject to change without notice

APR, 2018