

AD SERIES

Basic Scale

- Easy-to-operate, Compact design
- Available capacity : 2.5kg ~ 30kg
- Stainless steel platter
- Soft touch tact switch
- Easy-to-read VFD display
- Auto zero tracking
- Auto span adjustment



Printer (Option)



Easy-to-read VFD display



Baby tray (AD-15T)



Scan with your smartphone to find more products

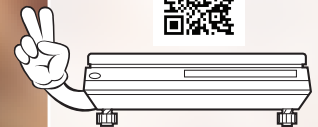

Printer (Option)

Easy-to-read VFD display

Baby tray (AD-15T)



AD SERIES

Basic Scale



DISPLAY & KEYBOARD



KEY SPECIFICATIONS



FEATURES

- Easy-to-operate, Compact design
- Available capacity : 2.5kg ~30kg
- Soft touch tact switch
- Stainless steel platter
- Easy-to-read VFD display
- Auto span adjustment
- Auto zero tracking

DIMENSIONS

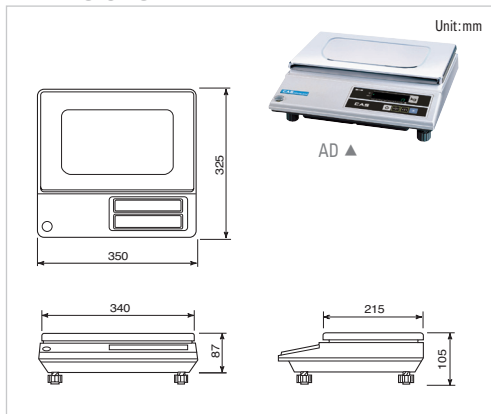

SPECIFICATIONS

Model	AD Series			
Max.capacity (kg)	1.5/3	3/6	6/15	15/30
Readability (g)	0.5/1	1/2	2/5	5/10
External resolution	1/3,000 (Dual interval)			
Display digit	7 digits			
Display type	VFD			
Operation temperature	-10°C ~ +40°C			
Power	AC 100-240V, 50/60Hz			
Platter size (mm)	340(W) x 215(D)			
Dimensions (mm)	350(W) x 325(D) x 105(H)			
Product weight (kg)	4.7			

OPTIONS

- RS-232C interface
- Baby tray (AD-T), Large tray
- Printer : DEP-50(Ticket), DLP-50(Label)



<DLP-50>



<DEP-50>

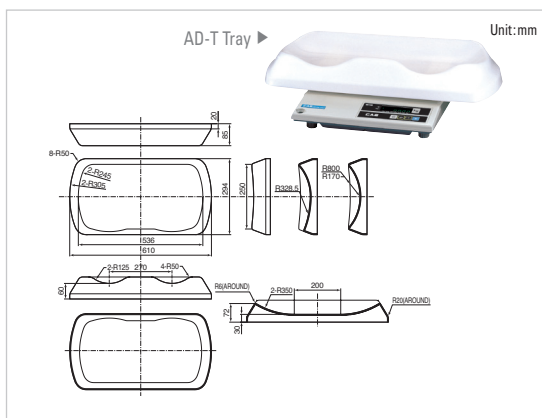

AD-T Tray ▶

Unit:mm

