



VFD Display



Pivot Type Indicator

AC & CS SERIES

Counting Scales

CAS AC & CS Digital Counting Scales are easy to use Industrial and Commercial Scales. Like most bench scales the AC Series is designed for rough industrial conditions and ideal for logistics. The CS Series is well suited for jewel & gem shops, component manufacturers and any material managing departments. The counting function saves both labour and time.

- AC Series: Pivot Type & Detachable Indicator



◀ AC Series



▲ CS Series



AC & CS SERIES | Counting Scales

AC TYPE

FEATURES

- Alarm Operation
- Attractive Design and Easy-to-Use
- Easy to read VFD Display
- Die Cast Platform and Stainless Steel Weighing Pan



SPECIFICATIONS

Model	25AC	50AC	100AC
Weighing Capacity	25kg x 5g	50kg x 10g	100kg x 20g
Display Digit	Count / Weight / Unit Weight (5/5/5)		
Power Source	AC 110 / 220V, 50 / 60Hz		
Power Consumption	Approx. 7W		
Operating Temperature	-10°C ~ 40°C		
Platter Size (mm)	390(W) x 510(D)		
Dimensions (mm)	420(W) x 610(D) x 825(H)		
Product Weight	19 kg		

DIMENSIONS

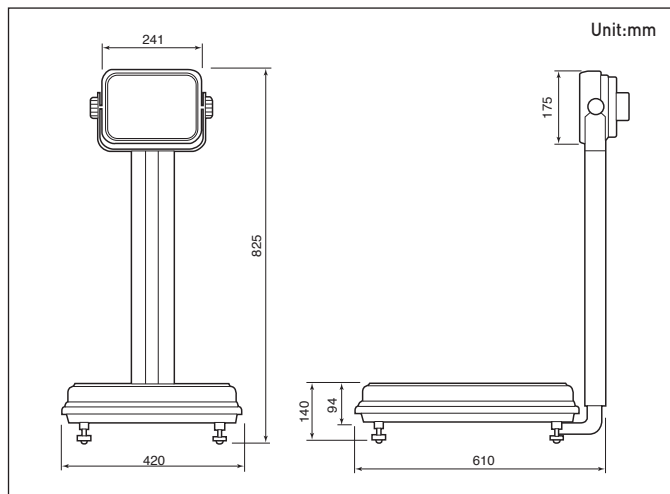

CS TYPE

FEATURES

- Low Profile Simple Design
- Easy-to-Use
- Zero, Tare, Q'ty, Unit Weight Function
- Easy-to-read VFD Display



SPECIFICATIONS

Model	2.5CS	5CS	10CS	25CS
Weighing Capacity	2.5kg x 0.5g	5kg x 1g	10kg x 2g	25kg x 5g
Display Digit	Count / Weight / Unit Weight (5/5/5)			
Display Designators	Zero, Tare, Lacked Sample, Lacked Unit Weight			
Power Source	AC 110 / 220V, 50 / 60Hz			
Power Consumption	Approx. 7W			
Operating Temp.	-10°C ~ 40°C			
Platter Size (mm)	340(W) x 215(D)			
Dimensions (mm)	350(W) x 325(D) x 105(H)			
Product Weight	5.3 kg			

DIMENSIONS

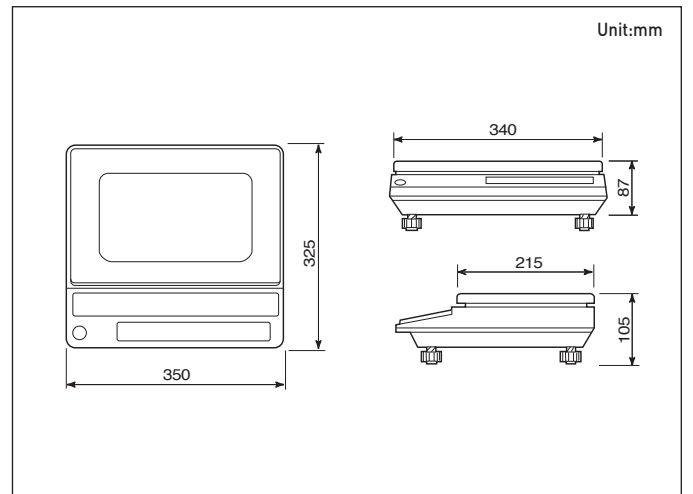

CAS

CAS BLDG., # 440-1, SUNGNAE-DONG,
GANGDONG-GU, SEOUL, KOREA

TEL_ 82 2 2225 3500

FAX_ 82 2 475 4668

<http://www.globalcas.com>

Specifications are subject to change for improvement without prior notice.