

CPS

Pallet Scale

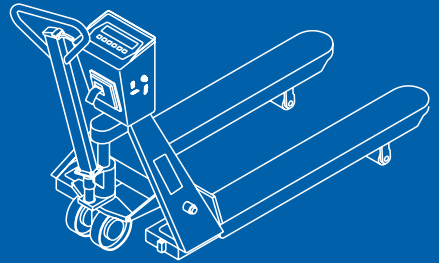

CAS

Table of Contents

1. PRECAUTIONS.....	4
2. OVERALL VIEW.....	5
3. SPECIFICATIONS	6
4. DIMENSIONS.....	6
5. FRONT PANEL	7
6. RS-232C(OPTION)	9
7. OPERATIONS.....	11
8. HOW TO CHARGE	13
9. TEST MODE	14
10. SET MODE	16
11. ERROR MESSAGE & TROUBLE SHOOTING	21

1. PREFACE...1

Thank you for the purchasing of our CAS CPS Series.

These series have been designed with CAS reliability, under rigid quality control and with outstanding performances. Your speciality departments can enjoy with these high quality reliable CAS products.

These electronic load cell scales eliminate the all the moving parts and furnish an accurate digital display of all information.

We believe that your needs will be satisfied and you will have proper reliability in variable weight.

This manual will help you with proper operations and care of the CPS scales.

Please keep it handy for the future references.

CAUTIONS

- ▶ Do not press the keys hardly, for the keys are in operation with soft touch.
- ▶ Do not use ignitable material for cleaning.
- ▶ Keep away CI-2001B from the rain.
- ▶ Avoid sudden temperature change.
- ▶ Do not install CI-2001B in a place with high voltage and excessive electrical noises.
- ▶ Keep it in dry place.
- ▶ Do not use under direct rays and dusty place.
- ▶ Do not use at the place with excessive electrical noises and vibration.

FEATURES

- ▶ CAS PALLET SCALE (CPS) weigh the pallet loads with accuracy.
- ▶ CPS's "lift and read" technology speed the loading and weighing process.
- ▶ We have 1000kg and 2000kg capacity models.
- ▶ Digital indicator displays the weight.
- ▶ Built-in printer (optional) You can record the weight of loads with printer.
- ▶ Built-in battery. you can use this scale without power outlet.

NOTICE : Specifications are subject to change for improvement without notice.

2. OVERALL VIEW

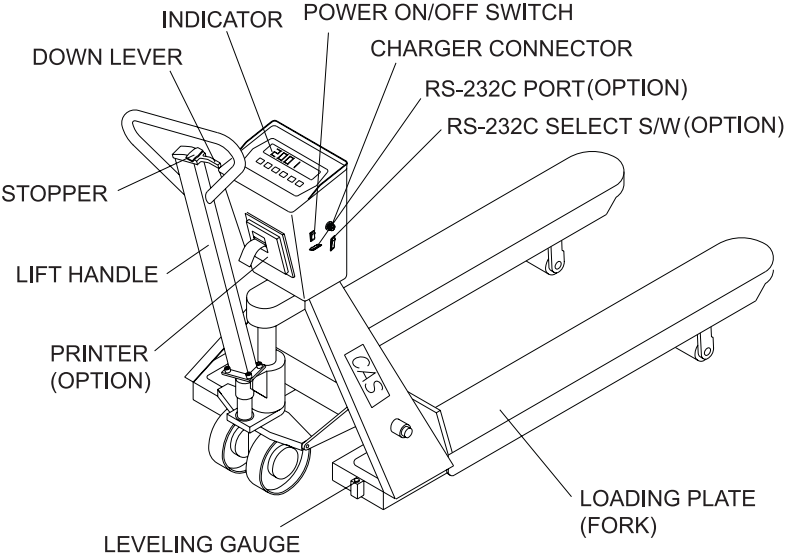

3. SPECIFICATIONS

MODEL NAME		CPS-1			CPS-2		
SIZE	TYPE	A	B	C	A	B	C
	W	540	620	705	540	620	705
	L	1080	1080	1200	1080	1080	1200
CAPACITY		1000 kg ×0.5 kg			2000 kg×1 kg		
OVERLOAD PROTECTION		1500 kg			2500 kg		
WEIGHT DISPLAY		5digit LCD (HEIGHT 25mm)					
POWER SUPPLY		DC6V/ 10AH BATTERY (AC 100V~240V CHARGER)					
ACCURACY		0.1%					
OPTION		PRINTER					
TEMPERATURE RANGE		-10℃ ~ 40℃					

4. DIMENSIONS

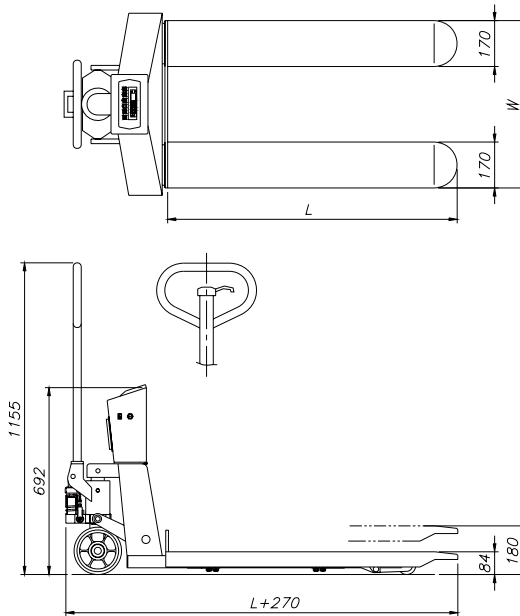

5. FRONT PANEL

■ kg version.



■ kg/lb version.

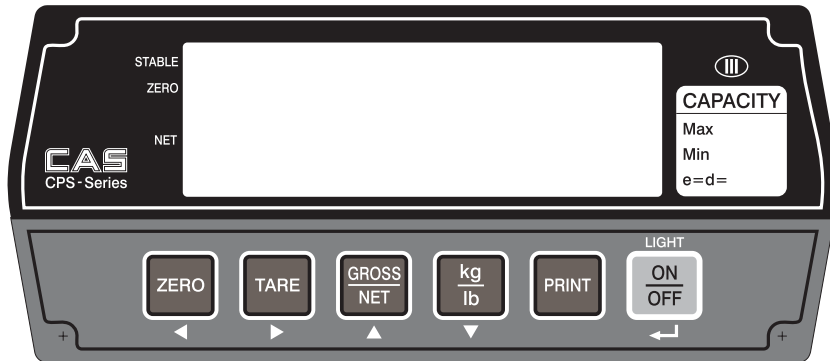

(1) Display lamp

lb lamp : ON when the weight unit is pound [lb]

kg lamp : ON when the weight unit is kilogram [kg]

o lamp : ON when the weight is stable.

ZERO lamp : ON when the current weight is 0 kg(0 lb).

NET lamp : ON when the current weight is NET weight.

BAT lamp :In case of rechargeable battery, display the battery recharging time

* Battery warning lamp

If Battery warning lamp turn on, CPS will power off after about 30 seconds

(2) Keyboard

- ▲, ◀ Key
 - Available keys instead of numeric keys.
 - ▲ : Change the set value
 - Increase the first place value to 1
 - ◀ : Change the digit of the set value
 - Move to the left by 1 place
 - USAGE : Input the numeral value in TEST, CAL, SET mode.

- ZERO Key : Return the display to 0.

- TARE Key
 - Use container in weighing.
 - Current weight is memorized as tare weight.
 - If you press TARE key in unload condition, Tare setting is released.

- GROSS/NET Key
 - Display gross and net weight by turn.
 - GROSS lamp on - gross weight
 - NET lamp on - net weight
 - In case tare weight is REGISTERED, tare and item's total weight is G weight and only item's weight is N. weight.

- kg/lb Key
 - Toggles between lb and kg units.

- "PRINT" Key
 - 1. PRINT Key
 - Total Print key
 - (by pressing "PRINT" key more than 3 second.)
 - 2. HOLD Key

- * key(Only kg version)
 - 1. Total print key. (F09 – 1)
 - 2. Hold key. (F09 – 2)

- ON/OFF key
 - 1. Back light ON/OFF key
 - 2. ON/OFF key (by pressing key more than 3 second.)
 - 3. Store current condition and exit in TEST, SET mode

6. RS-232C (OPTION)

(1) How to RS-232C Select switch

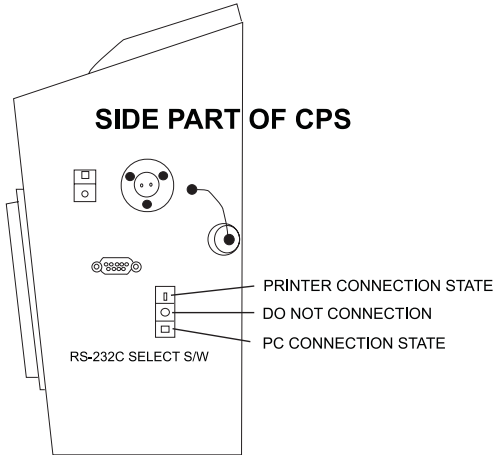

(2) How to connect PC

Connect the serial port on the rear panel of the indicator to serial port of PC as follows.

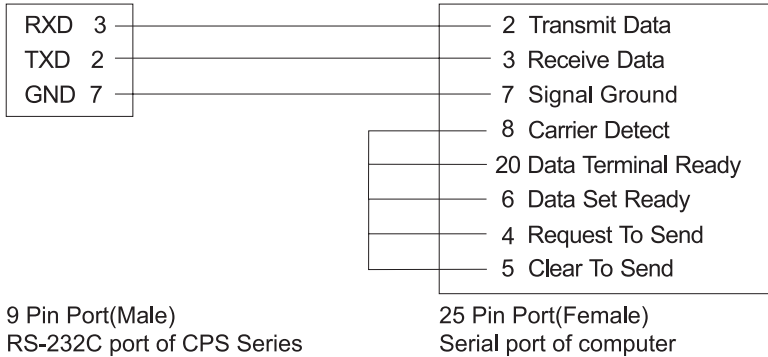

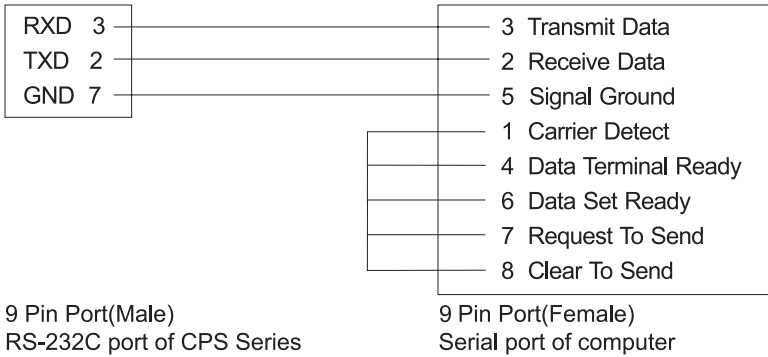

(3) How to connect Sub display

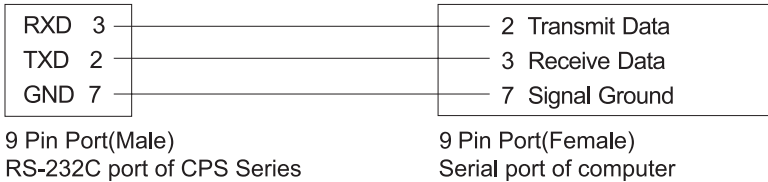

(4) Data format

- ① Baud rate : 120 bps – 19200 bps
Set Baud rate in SET mode. (See F20 at page 30)
- ② Data bit: 8, Stop bit : 1, Parity bit None
- ③ Code : ASCII
- ④ When data is sent to computer ? : Set in SET mode(See F12 at page 31.)
- ⑤ Format

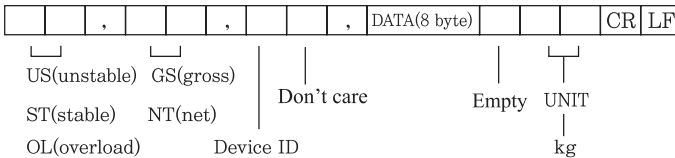

- Device ID : Transmit 1 byte so that the receiver can receive data selectively which indicator sent.(Device ID is selected in F10.)

Weight Data (8 byte)

- a. 13.5kg : “ ”, “ ”, “ ”, “ ”, “ ”, “1”, “3”, “.”, “5”
- b. 135kg : “ ”, “ ”, “ ”, “ ”, “ ”, “1”, “3”, “5”, “ ”
- c. -135kg : “-”, “ ”, “ ”, “ ”, “ ”, “1”, “3”, “5”, “ ”

7. OPERATIONS

(1) How to assembly

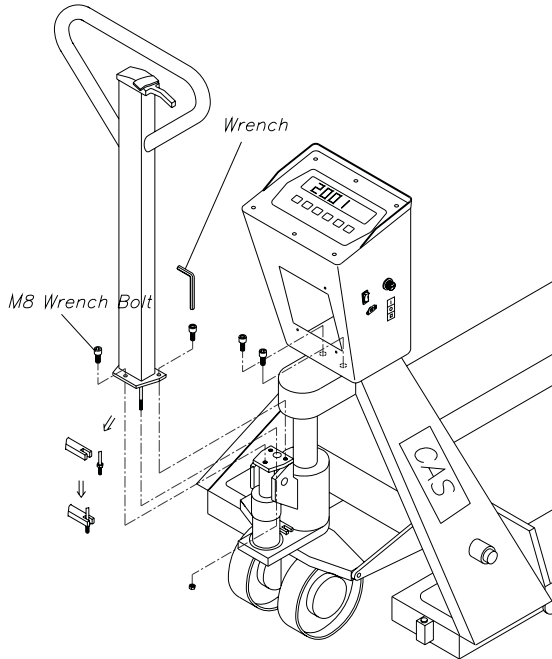

(2) Operations

1. Turn the power switch ON.

The power switch is located on the right side of the indicator.

WARNING : Avoid leaving **ANY** load before turn the power switch ON.

2. Pressing ON key of front panell

3. Display will show "0", make sure that ZERO lamp is ON.

4. When the FORK lift the load, weighing is performed.

WARNING : Fork have to properly level so as to center bubble of the leveling gauge inside the indicated circle and fork truck should not move.

5. If you want to adjust zero range, press the ZERO key.
6. If you want to use tare function, press the TARE key.
If you don't want to use tare function any more, remove the container(pallet) and press the TARE key.
7. If you want to down the fork, pull the DOWN LEVER.
If you want to lift the fork, press the STOPPER and operate the LIFT HANDLE.

8. HOW TO CHARGE

1. Plug the charger into a AC socket and make sure that the socket's power is within the charger's operating range.
Open the socket's cover located on the right side of indicator and then connect to the connector. (See Fig 1.)
2. Depending on the charging state, the lamp located on the charger will be ON.
3. When the battery is fully charged, the charger lamp will be ON.
4. It takes about 8 hours to fully charge the battery.

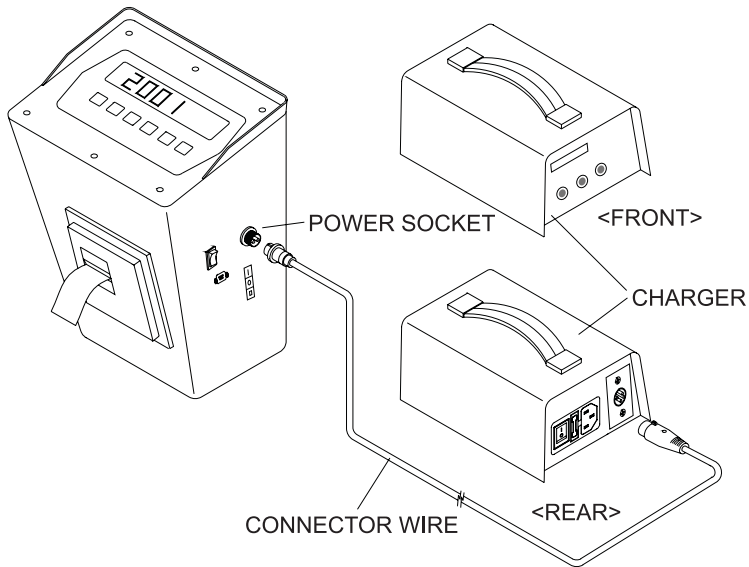

9. TEST MODE

(1) HOW TO ENTER

Turn on the power while pressing the 'ZERO' key and TEST menu starts.

(2) AVAILABLE KEYS & CONVERTING METHOD

▲ KEY : Increase the first place set value to 1

◀ KEY : Move to the left by 1 place of the set value.

PRINT(kg/lb version) or (kg version)KEY : Move to a weight measure mode

ON/OFF KEY : Move into next menu.

(3) TEST MENU(TEST1 – TEST5)

TEST 1 : Key test

TEST 2 : LCD display test

TEST 3 : Load cell test and A/D conversion test

TEST 5 : Print test

TEST 1

FUNCTION : Key test		
KEY	LCD DISPLAY	DESCRIPTION
ON/OFF key : Next menu Other key : Perform test	tEst 1 1	TEST 1 Condition Press the key to be test and the NO. And code of the key is displayed

<Key code>

KEY	CODE	KEY	CODE	KEY	CODE
ZERO	1	TARE	2	GROSS/NET	3
PRINT(kg version)	4	- (kg version)	5	ON/OFF	6
kg/lb (kg/lb version)	4	PRINT (kg/lb version)	5		

TEST 2

FUNCTION : LCD display test		
KEY	LCD DISPLAY	DESCRIPTION
		<p>TEST 2 condition</p> <p>TEST 2 is performed automatically</p>

Ref 1. Program is automatically shifted to menu selection mode after completing.

TEST 3

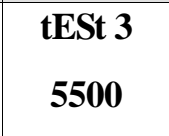
FUNCTION : A/D conversion test (L/C test)		
KEY	LCD DISPLAY	DESCRIPTION
<p>ON/OFF key : Next menu</p> <p>Other key : Perform test</p>		<p>TEST 3 Condition</p> <p>Display digital value of current weight.</p> <p>This value means converted digital value.</p>

Ref 1. Check whether digital value is changing. If the digital value is fixed or zero is displayed. Please check the connection of the load cell.

TEST 5

FUNCTION : Printer test		
KEY	LCD DISPLAY	DESCRIPTION
<p>ON/OFF key :</p> <p>Exit test mode</p> <p>Other key : Perform test</p>		<p>TEST 5 Condition</p> <p>No error in printer.</p> <p>Check printer connector</p>

Ref 1. “Good” message is displayed if the printer connection and specification is done correctly. If not, “Err 06” message is displayed.

Ref 2. The test output format of printer is like follows.

TEST OK

10. SET MODE

(1) HOW TO ENTER

Turn on the power while pressing the "ZERO" key and SET menu starts.

(2) AVAILABLE KEYS & CONVERTING METHOD

▲ KEY : Increase the first place set value to 1

◀ KEY : Move to the left by 1 place of the set value.

PRINT KEY(kg/lb version) or *(kg version)KEY : Move to a weight measure mode

ON/OFF KEY : Move into next menu.

(3) SET VALUE CONVERSION MENU (F01 - F14)

F01 : Select the primary base unit (kg/lb)

F02 : Designation of serial port usage

F03 : Automatic zero condition set

F04 : Digital Filter

F07 : Weight Back-up (Power-on Actual Weight)

F08 : "PRINT" Key Usage

F10 : Device ID

F11 : Designation of Serial Interface Baud rate

F12 : Designation of Serial Interface output mode

F13 : Set HOLD type

F14 : Select of clock option

F17 : Print line feed

F18 : Display mode

Select the primary base unit		
F01	0	primary unit is kg
	1	primary unit is lb

Serial port usage		
F02	0	Not Usage
	1	Connection to serial Printer

Normal Print sample

```

2008.12.10 09:44:43
001, 0.200 lb
2008.12.10 09:44:47
002, 0.200 lb

```

Total Print sample

```

2008.12.10 09:44:43
001, 0.200 lb
2008.12.10 09:44:47
002, 0.200 lb
---- Total Print ----
2008.12.10 10:11:48
Count:002, 0.400lb
-----

```

Automatic Zero condition set			
F03	0	None Automatic zero	
	1	1 : 0.5 digit	Autozero tracking will automatically bring the display back to "0" when there are small deviations.
	9	9 : 4.5 digit	

Digital Filter			
F04	1	1 : Less Vibration	Adjust the set value according to the condition.
	~ 9	: 9 : Much Vibration	

Select the weight back-up mode		
F07	0	Weight back-up is off (Power on Zero)
	1	Weight back-up is on

"PRINT" Key Usage		
F08	0	Not used
	1	- Print key (Press "PRINT" key) - Total Print key (by pressing "PRINT" key more than 3 second.)
	2	HOLD Key

Device ID			
F10	00	00: DEVICE ID "00"	It is used the no. of indicator when system is connected.
	~ 9	: 9 : DEVICE ID "9"	

Baud Rate		
F11	0	600 bps
	1	1200 bps
	2	2400 bps
	3	4800 bps
	4	9600 bps
	5	19200 bps

Output Mode		
F12	0	No data output
	1	Stream Mode
	2	Only one time data transmit at stable weight.
	3	Transmit when data is required Request signal : device ID (F10 : Device ID) (In case F10 : 1, Send Hex Value 01hex in Computer)

* If you want to Use F12 must set F2=0

Set HOLD type		
F13	0	Average hold : Compute the average weight of oscillating weights.
	1	Peak hold : Compute the maximum weight among oscillating weights.

* If you want to use F13 must set F9=2

Select Option Clock		
F14	0	Not use Clock
	1	use Clock

Change Date/Time (Ex. 1998/12/11 13:10:01)		
▲ : Increase of no. ◀ : Shift of digit LIGHT : Store and move into next menu	LED Display	Meaning
	C1 98	Year : 98
	C2 12	Month : 12
	C3 11	Day : 11
	C4 13	Hour : 13
	C5 10	Minute : 10
	C6 01	Second : 01

Print line feed		
F17	1	1 Line feed
	2	2 Line feed
	3	3 Line feed
	4	4 Line feed
	5	5 Line feed

Display mode		
F18	0	Always display weight in Normal
	1	When stable, display weight in Normal

11. Error message & Trouble shooting

Err 02

- Reason
Load cell connection failure or error in A/D conversion part.
- ☞ Trouble shooting
Check the load cell connector to see if the polarity of signal is reversed.

Err 06

- Reason
Error in printer connection
- ☞ Trouble shooting
Check with printer connector
If there is no problem with printer and printer connector, please request A/S to head office.

Err 09

- Reason
Current weight deviates from zero range.
- ☞ Trouble shooting
Press the ZERO key within 2% of the maximum capacity.

Err 10

- Reason
Tare weight exceeds the maximum capacity of the scale.
- ☞ Trouble shooting
Set the tare to be smaller than the maximum capacity.
Otherwise the maximum capacity is reset to be larger than the tare to be set in the calibration menu, and reset the calibration using weight.

Err 13

- Reason
The zero range deviates from the set range.
- ☞ Trouble shooting
Confirm that there is nothing on the weighing platform.
If nothing exit, do calibration in CAL mode.

Over

■ Reason

The weight on platform is too heavy to be measured.

■ Trouble shooting

Do not load the item exceeds the maximum tolerance.

If the load cell is damaged, the load cell should be replace.

MEMO

CPS

Pallet Scale