

NC - 1

Crane Scale

- Available in 100 × 0.05 kg, 200 × 0.1 kg, or 500 × 0.2 kg Capacities
- Rechargeable Battery / AC Adapter
- Easy-to-Read LCD with Backlight Display



CAS



NC-1 Crane Scale

FEATURES

- Battery Operated with Low Battery Indication
- Standard AC Adapter
- Aluminum Die-casting Case
- On/Off, Zero, Tare, and Hold(or kg/lb) Functions
- Easy-to-Read LCD Display with Backlight Feature
- Auto Span Adjustment
- Auto Zero Tracking
- Wireless Remote Control

SPECIFICATIONS

Model	NC -1		
Weighing Capacity	100 × 0.05 kg	200 × 0.1 kg	500 × 0.2 kg
Maximum Tare	Full Tare		
Display Type	LCD (1 inch)		
Operating Power	DC 12V(1.5A)		
Power Source	AC 110/120/220/240 V, 50/60 Hz		
Display Designators	Zero, Tare, Batt.		
Power Consumption	0.25 W		
Operating Temperature	-10° C ~ +40° C		
Dimension (mm)	260(W) × 134(D) × 480(H)		
Product Weight	5.5 kg		

DIMENSIONS

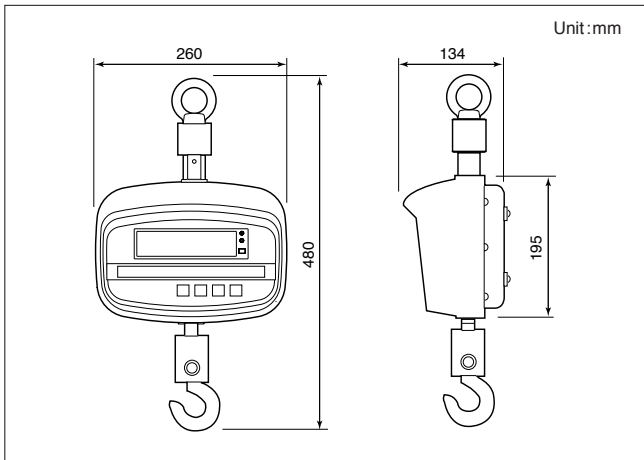

DISPLAY & KEYBOARD



◀ Remote Control

CAS

CAS BLDG., # 440-1, SUNGNAE-DONG,
GANGDONG-GU, SEOUL, KOREA
TEL : 82-2-2225-3500
FAX : 82-2-475-4668
<http://www.cas.co.kr>

Specifications are subject to change for improvement without prior notice.