



High-visibility LED display



Lightweight & Robust enclosure



Swivel hook

HD SERIES

Crane Scale

HD series is high accuracy, compact crane scale for low capacity applications such as livestock industry and agriculture, fisheries with High-visibility LED display and lightweight and Robust enclosure.



CAS

HD SERIES | Crane Scale

High-visibility LED display

User can easily see the weight value in any distance via high-visibility LED display.



Lightweight & Robust enclosure

Via lightweight and robust enclosure, suitable for low capacity applications such as livestock industry and agriculture, fisheries etc.

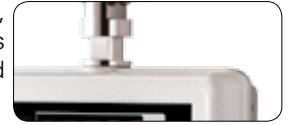

TECHNICAL DATA

Model	HD series		
Max. Capacity (kg)	100	200	500
Division (g)	50	100	200
Display	LED (0.8 inch)		
Status Lamp	Zero, Tare, Charging, Low Bat		
Operating Temperature	-10°C ~ +40°C		
Power	DC 6V Rechargeable battery/ AC Adaptor		
Battery operating time (Continuous Operating)	Approx. 50 hour		
Battery charging time	Approx. 12 hour		
Product size (W x D x H / mm)	266 x 116 x 476		
Product weight	Approx. 6.5 kg		

Swivel Hook

HD series offers convenient and safe weighing and accuracy through swivel hook.



FEATURES

- High-visibility LED display (0.8inch)
- Lightweight & Robust enclosure
- Built in rechargeable battery and Low battery status lamp
- Key function : Power On/off, Zero, Tare, Hold
- Auto power off / Sleep mode / Hold function
- Swivel hook (360° movement of working load)

OPTIONS

- Double hook



DIMENSIONS

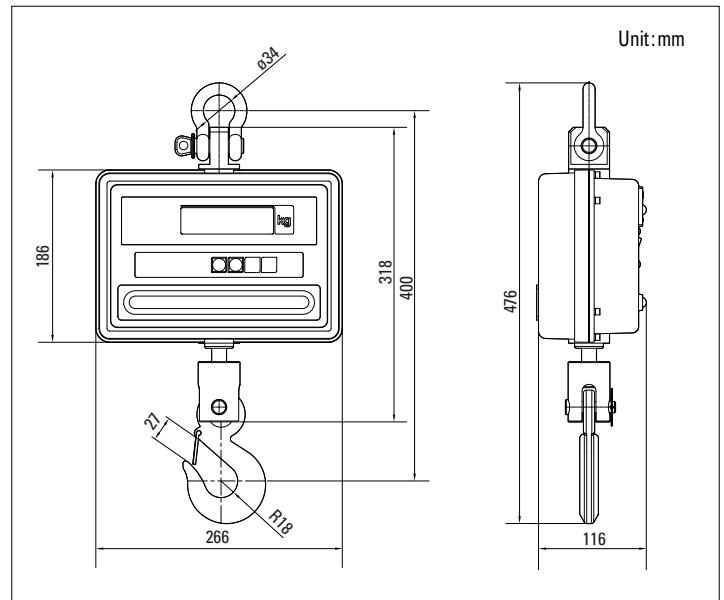

CAS

CAS BLDG., # 440-1, SUNGNAE-DONG,
GANGDONG-GU, SEOUL, KOREA

TEL_ 82 2 2225 3500

FAX_ 82 2 475 4668

<http://www.globalcas.com>

Specifications are subject to change for improvement without prior notice.