

Weighing Indicator

CI-2001AS/BS

OWNER'S MANUAL



9007-C2B-0033-0

2000, 7



CONTENTS

PRECAUTIONS	4
INTRODUCTION	6
THE FEATURES OF CI-2001AS/CI-2001BS	6
TECHNICAL SPECIFICATION	7
DIMENSIONS	8
FRONT PANEL (CI-2001AS)	9
FRONT PANEL (CI-2001BS)	11
CONNECTING THE CABLE	13
TEST MODE	14
CALIBRATION MODE	17
SET MODE	20
SERIAL INTERFACE	24
ERROR MESSAGE & TROUBLE SHOOTING	28

PRECAUTIONS

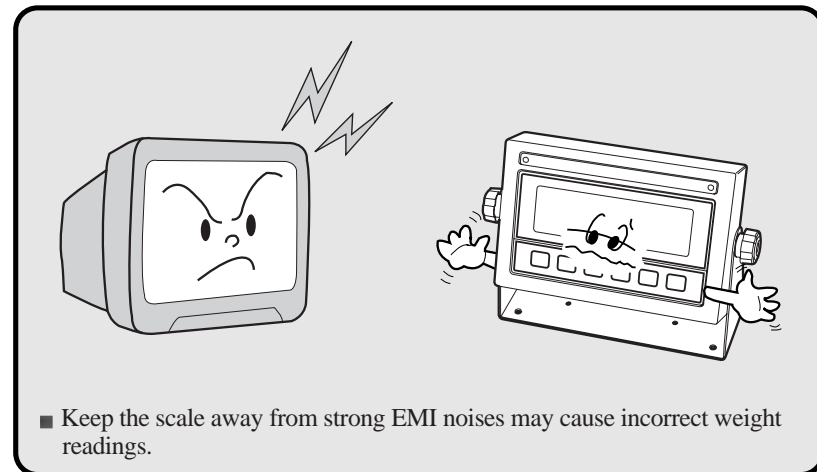
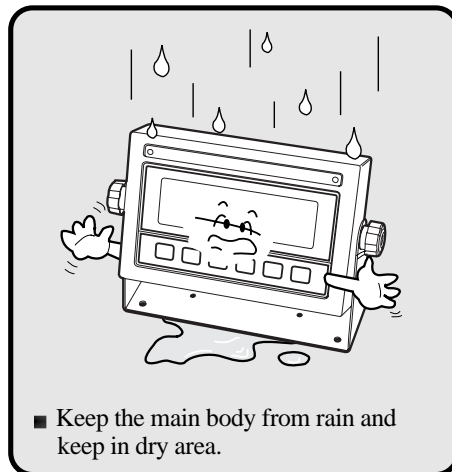
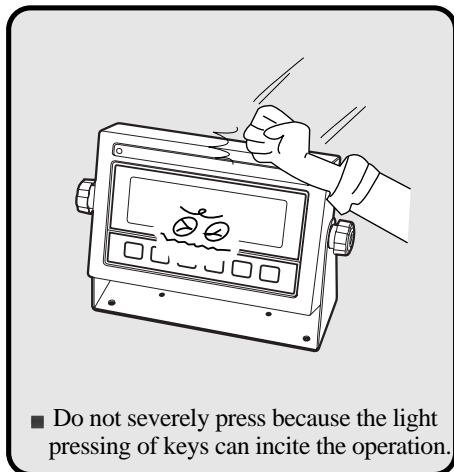
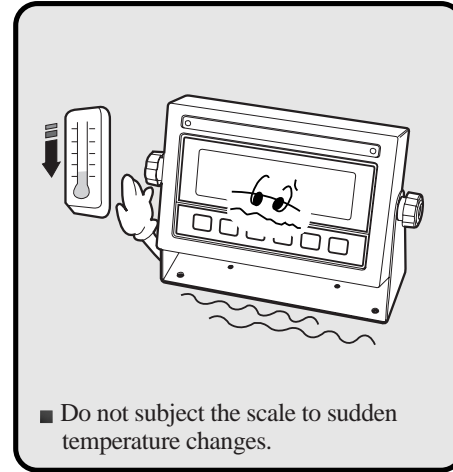
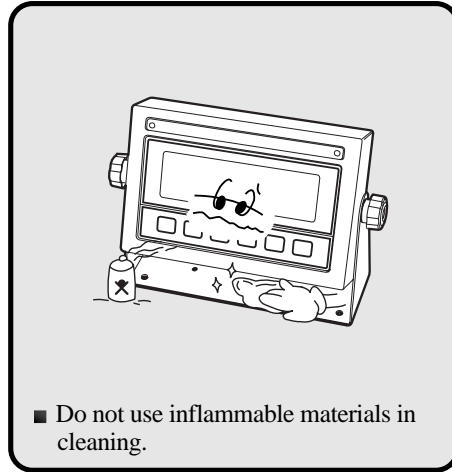
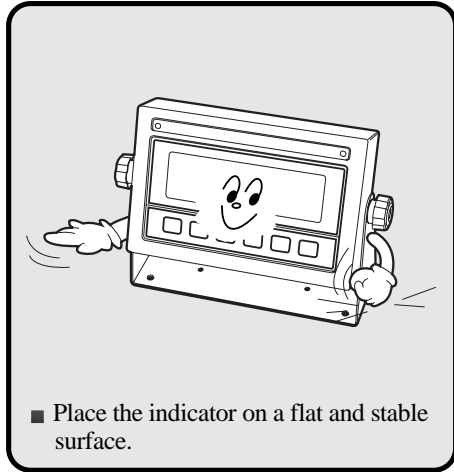

INTRODUCTION

We greatly appreciate your purchase of the CAS industrial indicator. These goods have hold excellent performance and splendid properties through strike tests as well as devoting ourselves under severe quality management.

CAS indicator(CI-series) is shaped firmly and delicately designed a coincide with the special requirements of several industrial fields and includes many functions and various external interfaces. Also, it is programmed on the basic of the user's convenience and contains help display functions to be used easily.

Before using CI-2001AS/BS, It is recommended to read this manual carefully and to apply the function application fully.

THE FEATURES OF CI-2001AS/CI-2001BS

1. Features

- Appropriate for weight and measurement system
- Easy operation and various functions
- Simple full digital calibration
(SPAC™: Single pass automatic span calibration)
- Watchdog circuitry (System restoration)
- Wall mount type (CI-2001AS/BS)-Standard

2. Main Function

- Various specification of weight conversion speed (Digital filter function)
- Various printer connection (RS232 Serial printer)
- Users can set the desirous max. weight and a division freely
- Self hardware test
Prompt A/S is available for test of each part of circuit by module is possible

TECHNICAL SPECIFICATION

Analog Part	
Load cell excitation voltage	DC 5V, up to 4 × 350 Ω load cells
Full scale input signal	20mV, including dead load
Zero adjust range	0.05mV ~ 5mV
Input sensitivity	2 μ V/D (H-44, OIML) 0.5 μ V/D (Non H-44, OIML)
System linearity	Within 0.01% of FS
A/D internal resolution	Approximately 200,000 counts
A/D external resolution	5,000dd (H-44, OIML) 30,000dd (Non H-44, OIML)
A/D conversion speed	10 times/sec

Digital Part		
Span calibration	Full Digital Calibration: SPAC™ (Single pass automatic span calibration)	
Display	CI-2001AS	LED(6 digit)
	CI-2001BS	LCD(5 digit)
Size of letter	CI-2001AS	25mm(Height)
	CI-2001BS	25mm(Height)
Display below zero	“-” minus signal	
Additional symbols	CI-2001AS	Zero, Tare, Gross, Net, Stable
	CI-2001BS	Zero, Net, Stable
AC adapter	AC 110V/220V, 50/60Hz (DC 12V, 500mA)	
Power consumption	CI-2001AS	10W
	CI-2001BS	1W
Operating temperature	-10°C ~ +40°C	
Overall dimensions	200mm × 130mm × 53mm	
Weight	2kg	

Option Part

Option-1	Serial Interface: RS-422/485
Option-2	Inner Clock
Option-3	Built in Battery

DIMENSIONS

CI-2001AS/BS Wall Mount Type

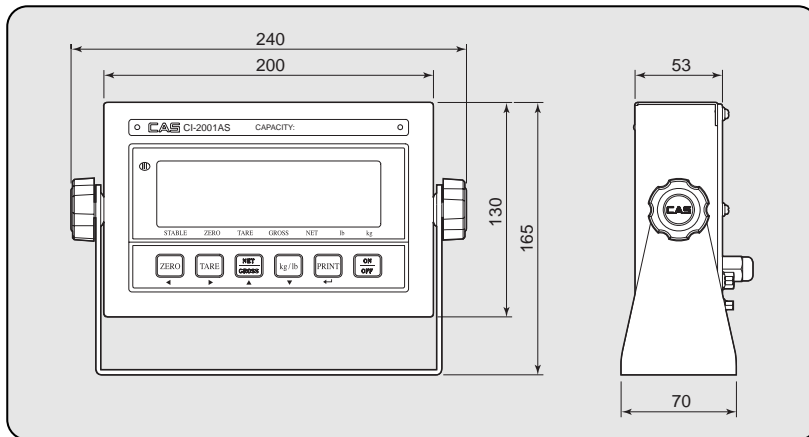

FRONT PANEL (CI-2001AS)

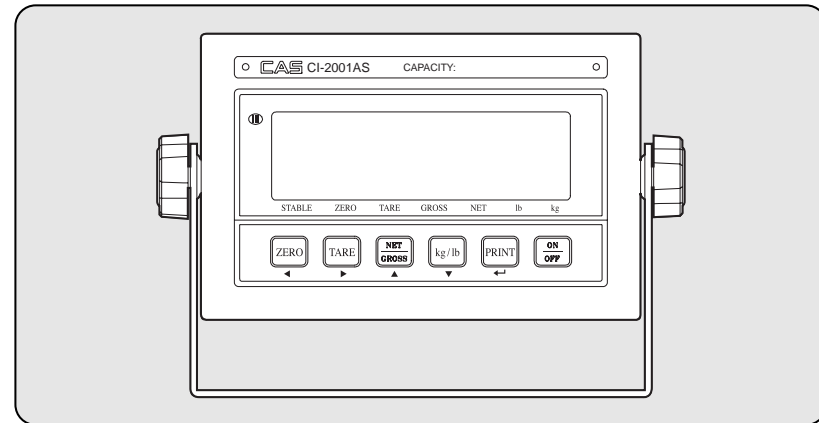

1. Display Lamp (■)

- STABLE lamp: ON when the weight is stable.
- GROSS lamp: ON when the current weight is GROSS weight.
- NET lamp: ON when the current weight is NET weight.
- TARE lamp: ON when the tare weight is stored.
- ZERO lamp: ON when the current weight is 0kg (0lb).

2. Keyboard

▲ ◀ Available keys instead of numeric keys.

- ▲: Change the set value
Increase the first place value to 1
- ◀: Change the digit of the set value
Move to the left by 1 place

USAGE: Input the numeral value in TEST, CAL, SET mode.

ZERO Return the display to 0.

TARE

Use container in weighing.

Current weight is memorized as tare weight.

If you press TARE key in unload condition, tare setting is released.

GROSS/NET

Display gross and net weight by turn.

GROSS lamp on - gross weight

NET lamp on - net weight

In case tare weight is REGISTERED, tare and item's total weight is G. weight and only item's weight is N. weight.

PRINT (CI-2001AS kg only version)

- PRINT key
- Total Print key
(by pressing "PTINT" key more than 3 second.)

kg/lb (CI-2001AS kg/lb conversion version)

Toggles between lb and kg units

ENTER

- PRINT key (CI-2001AS kg only version)
- Total Print key
(by pressing "PRINT" key more than 3 second.)
- Total PRINT key (CI-2001AS kg/lb conversion version)
- HOLD key
- In CALIBRATION, TEST, SET mode.
: Store current condition and exit.

3. How to enter TEST mode

- Press the "On/Off" key while pressing the "PRINT" key and TEST mode starts. (CI-2001AS kg only version)
- Press the "On/Off" key while pressing the "kg/lb" key and TEST mode starts. (CI-2001AS kg/lb conversion version)

4. How to enter SET mode

- Press the "On/Off" key while pressing the "ENTER" key and SET mode starts.

5. How to enter CAL mode

- Press the "On/Off" key while pressing the CAL switch on the rear panel of the indicator and CAL mode starts.

FRONT PANEL (CI-2001BS)

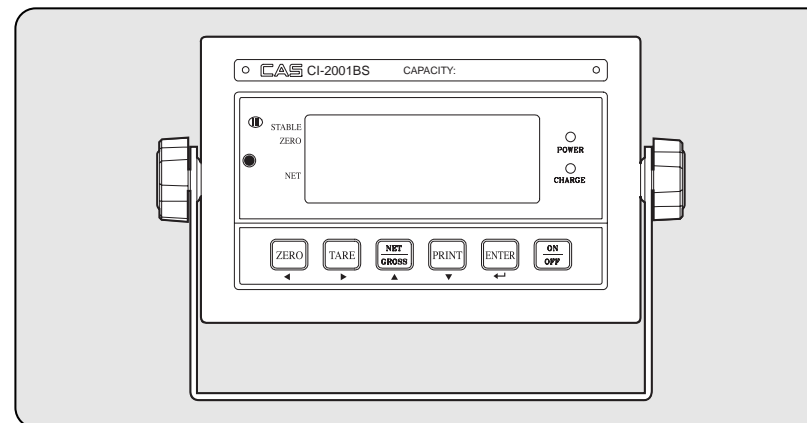

1. Display Lamp (■)

- kg lamp: ON when the weight unit is kilogram [kg].
- lb lamp: ON when the weight unit is pound [lb].
- STABLE lamp: ON when the weight is stable.
- NET lamp: ON when the current weight is NET weight.
- ZERO lamp: ON when the current weight is 0kg (0lb).

2. Keyboard

▲ ◀ Available keys instead of numeric keys.

- ▲: Change the set value
Increase the first place value to 1
- ◀: Change the digit of the set value
Move to the left by 1 place

USAGE: Input the numeral value in TEST, CAL, SET mode.

ZERO Return the display to 0.

TARE

Use container in weighing.

Current weight is memorized as tare weight.

If you press TARE key in unload condition, tare setting is released.

GROSS/NET

Display gross and net weight by turn.

GROSS lamp on - gross weight

NET lamp on - net weight

In case tare weight is REGISTERED, tare and item's total weight is G. weight and only item's weight is N. weight.

PRINT (CI-2001BS kg only version)

- PRINT key
- Total Print key
(by pressing "PTINT" key more than 3 second.)

kg/lb (CI-2001BS kg/lb conversion version)

Toggles between lb and kg units

ENTER

- PRINT key (CI-2001BS kg only version)
 - Total Print key
(by pressing "PRINT" key more than 3 second.)
- Total PRINT key (CI-2001BS kg/lb conversion version)
- HOLD key
- LCD manual back light key
- In CALIBRATION, TEST, SET mode.
 - : Store current condition and exit.

3. How to enter TEST mode

- Press the "On/Off" key while pressing the "PRINT" key and TEST mode starts.
(CI-2001BS kg only version)
- Press the "On/Off" key while pressing the "kg/lb" key and TEST mode starts.
(CI-2001BS kg/lb conversion version)

4. How to enter SET mode

- Press the "On/Off" key while pressing the "ENTER" key and SET mode starts.

5. How to enter CAL mode

- Press the "On/Off" key while pressing the CAL switch on the rear panel of the indicator and CAL mode starts.

CONNECTING THE CABLE

- DC ADAPTER (0V, +12V): Port for DC power.
 - DC 12V adapter is available
- RS-485 Interface (485_SIG+, 485_SIG-):
Serial interface port. (Computer ...)
- RS-232 Interface (232_RXD, 232_TXD, GND):
Serial interface port. (Computer, Printer, Remote Display)
- LOAD CELL (Ex+, Ex-, Sig+, Sig-, GND):
Port for connecting load cell.

Legal seal installed

- Install the seal on the wire loop as shown in below figure.

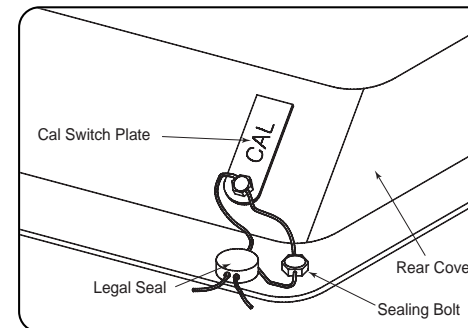



TEST MODE

1. How to Enter

Press the power while pressing the “PRINT” key and TEST menu starts.
(CI-2001AS/BS kg only version)

Press the power while pressing the “kg/lb” key and TEST menu starts.
(CI-2001AS/BS kg/lb conversion version)

2. Available Keys

-  Increase the first place set value to 1.
-  Move to the left by 1 place of the set value.
- PRINT** Initial ('0') of the set value. (CI-2001AS/BS kg type)
- kg/lb** Initial ('0') of the set value. (CI-2001AS/BS kg/lb)
- ENTER(↵)** Move into next menu.

3. TEST Menu (TEST 1 - TEST 5)

- TEST 1 : Key test
- TEST 2 : LED/LCD display test
- TEST 3 : Load cell test and A/D conversion test
- TEST 4 : Serial interface test (RS-232)
- TEST 5 : Printer test

TEST 1

- Function: Key test

Key	Display	Description
ENTER: Next menu Other keys: Perform test		TEST 1 condition. Press the key to be tested and the No, and code of the key is displays. Key mode should be identify with code of key like above.

<Key list>

CI-2001AS/BS kg only version		CI-2001AS/BS kg/lb version	
Key	Code	Key	Code
ZERO	2	ZERO	2
TARE	3	TARE	3
G/N	4	G/N	4
PRINT	5	kg/lb	5
ENTER	6	ENTER	6

TEST 2

- Function: LED/LCD display test

Key	Display	Description
Displaying all lamps of key		TEST 2 condition. TEST 2 is performed automatically after 3 seconds or so.

- ▶ REF 1. Program is automatically shifted to test 3 after completing Test 2.

TEST 3

- Function: A/D converter test (L/C test)

Key	Display	Description
ENTER: Next menu Other keys: Perform test		TEST 3 condition. Display digital value of current weight. This value means converted digital value.

- ▶ REF 1. A/D converter test is automatically completed by displaying converted digital value of current weight.
- REF 2. L/C test is also completed by loading the weight on the platform.
Check whether digital value is changing.
If the digital value is fixed or zero is displayed, please check the connection of the load cell.

TEST 4

- Function: RS-232 test with computer

Key	Display	Description
ZERO: Transmit '1'	2 2 5 2 4	TEST 4 condition.
TARE: Transmit '2'	0 - - - 0	Wait for transmission and reception.
G/N: Transmit '3'	0 - - - 1	Receive: 1, Transmit: none
PRINT: Transmit '4'	0 - - - 1	Receive: 1, Transmit: 13
ENTER: Next menu	1 2 - - 0 1	

▶REF 1. Do this test after the connection between serial port of computer and serial port of indicator.

REF 2. Send No.1 in computer keyboard and check if indicator receives No.1.
Send No.1 in indicator keyboard and check if computer receives No.1.

REF 3. Do this test after baud rate is specified in SET mode(F11).

※INDICATOR TEST(when it isn't connected with PC)

- 1) Connect directly between No.2(TXD) and No.3(RXD) in indicator of serial port.
- 2) If transmitting data is identical with receiving data by pressing key of front panel, this test will be done.

TEST 5

- Function: Printer test

Key	Display	Description
ENTER: Exit test mode	2 2 5 2 5	TEST 5 condition.
Other keys: Perform test	GOOD	No error in printer.
	ERR 06	Check printer connector.

▶REF 1. "GOOD" message is displayed if the printer connection and specification is done correctly. If or not, "ERR 06" message is displayed.

REF 2. The test output format of printer is like follows.

TEST OK

If you press the enter key, it will be returned to NORMAL MODE.
However, only when it is connected with printer, this test can be performed.

CALIBRATION MODE

1. How to Enter

Press the power while pressing the CAL switch on the rear panel of the indicator and CAL mode starts.

2. Available Keys

- ▲ Increase the first place set value to 1.
- ◀ Move to the left by 1 place of the set value.
- PRINT** Initial ('0') of the set value. (CI-2001AS/BS kg type)
- kg/lb** Initial ('0') of the set value. (CI-2001AS/BS kg/lb)
- ENTER(↵)** Move into next menu.

3. CALIBRATION Menu(CAL 1 - CAL 5)

- CAL 1 : Maximum capacity
- CAL 2 : Minimum division
- CAL 3 : Setting weight
- CAL 4 : Zero calibration
- CAL 5 : Span calibration

CAL 1

- Function: Maximum capacity set
- Range → 1 ~ 999,999kg/lb(CI-2001AS)
- 1 ~ 99,999kg/lb(CI-2001BS)

Key	Display	Description
▲: Increase of no.	2 105	Program version.
◀: Shift of digit	2 0 1 1	CAL 1 condition.
ENTER: Store and move into next menu	100	100kg(lb)
	Maximum capacity value	

▶REF 1. The maximum capacity means the maximum weight that scale can measure.

CAL 2

- Function: Minimum division set
Range → 0.0005 ~ 100kg/lb

Key	Display	Description
▲: Input the next division	CAL 2	CAL 1 condition.
ENTER: Store and move into next menu	0.01 Minimum division value	0.01 kg (lb)

- ▶ REF 1. The minimum division means the value of one division.
- REF 2. External resolution is obtained by division the min. division by the maximum capacity. Set the resolution to be within 1/30,000.

CAL 3

- Function: Setting weight in span calibration
Range → 1 ~ 999,999kg/lb (CI-2001AS)
1 ~ 99,999 kg/lb (CI-2001BS)

Key	Display	Description
▲: Increase of no. ◀: Shift of digit	CAL 3	CAL 3 condition.
ENTER: Store and move into next menu	100 Setting weight	100kg (lb)

- ▶ REF 1. The weight shall be within the range of 1% ~100% of maximum weight.
- REF 2. If the setting weight is under the 1% of the maximum capacity.
Error message ("ERR 22") will occur.
- REF 3. If the setting weight over the maximum capacity.
Error message ("ERR 23") will occur.

CAL 4

- Function: Zero calibration

Key	Display	Description
ENTER: Zero calibration and move into next menu	CAL 4 UnLoad ----- Good	CAL 4 condition. Unload the tray and press ENTER. Under zero calibration. Zero calibration is completed.

- ▶ REF 1. If zero calibration is done without any error, GOOD message is displayed and program moves into CAL 5 automatically.
- REF 2. If the "ZERO" key is press, only zero calibration is completed and program moves SAVE & EXIT mode. Press ENTER key.

CAL 5

- Function: Span calibration

Key	Display	Description
ENTER: Span calibration and move into next menu	CAL 5 Load ----- Good	CAL 5 condition. Load the weight which was set in CAL 3 and press ENTER. Under span calibration. Span calibration is completed. Remove the setting weight. Press the "ENTER" key to save the value.





- ▶ REF 1. If span calibration is done without any error, GOOD message is displayed the weight of setting weight is displayed on display screen.
Check the weight.
- REF 2. If the span is low, error message (ERR 24) is displayed.
Calibrate with lower resolution.
- REF 3. After setting the exact value, remove the setting weight and press the "ENTER" key to save the value.

SET MODE

1. How to Enter

Turn on the power while pressing the “ENTER” key and SET menu starts.

2. Available Keys

-  Increase the first place set value to 1.
-  Move to the left by 1 place of the set value.
-  Initial ('0') of the set value. (CI-2001AS/BS kg type)
-  Initial ('0') of the set value. (CI-2001AS/BS kg/lb)
-  Move into next menu.

3. Set Value Conversion Menu (F01 - F14)

- F01 : Select the primary base unit (kg/lb type)
- F02 : Designation of serial port usage
- F03 : Automatic zero tracking compensation
- F04 : Digital filter
- F07 : Weight back-up (power-on actual weight)
- F09 : “ENTER” key usage (CI-2001AS kg type)
- F09 : “ENTER” key usage (CI-2001AS kg/lb type)
- F09 : “ENTER” key usage (CI-2001BS kg type)
- F09 : “ENTER” key usage (CI-2001BS kg/lb type)
- F10 : Device ID
- F11 : Designation of serial interface baud rate
- F12 : Designation of serial interface output mode
- F13 : Set HOLD type
- F14 : Select of clock option

Select the primary base unit (CI-2001AS/BS kg/lb version)		
F01	0	Primary unit is kg
	1	Primary unit is lb

Serial port usage		
F02	0	Connection with computer and sub-display (CD-3000A)
	1	Connection with serial printer

Automatic zero tracking			
F03	0	None automatic zero	Autozero tracking will automatically bring the display back to “0” when there are small deviations.
	1	1 : 0.5 digit	
	~ 9	9 : 4.5 digit	

Digital filter			
F04	1	1 : Less vibration	Adjust the set value according to the condition.
	~		
	9	9 : Much vibration	

Select the weight back-up mode		
F07	0	Weight back-up is off (Power on zero)
	1	Weight back-up is on (Display setting weight)

“ENTER” key usage (CI-2001AS kg version)		
F09	0	Not used
	1	Total print key
	2	HOLD key

“ENTER” key usage (CI-2001AS kg/lb version)		
F09	0	Not used
	1	- Print key (Press “PRINT” key) - Total Print key (by pressing “PRINT” key more than 3 second.)
	2	HOLD key

"ENTER" key usage (CI-2001BS kg version)		
F09	0	Not used
	1	Total print key
	2	HOLD key
	3	LCD manual back-light key

"ENTER" key usage (CI-2001BS kg/lb version)		
F09	0	Not used
	1	- Print key (Press "PRINT" key) - Total Print key (by pressing "PRINT" key more than 3 second.)
	2	HOLD key
	3	LCD manual back-light key

Device ID			
F10	00	00 : Device ID "00"	It is used the no. of indicator when system is connected.
	~		
	99	99 : Device ID "99"	

Baud rate		
F11	0	600 bps
	1	1200 bps
	2	2400 bps
	3	4800 bps
	4	9600 bps
	5	19200 bps

Output mode			
F12	0	In case selecting No.1 of F02, this function must be set up.	No data output
	1		Stream mode
	2		Transmit only in stable condition
	3		Transmit when data is required → Request signal: device ID (F10 : Device ID) → In case F10 : 1, send hex value 01h in computer

Set HOLD type		
F13	0	Average hold: Compute the average weight of oscillating weights.
	1	Peak hold: Compute the maximum weight among oscillating weights.
	2	Sampling hold

Select option clock		
F14	0	Not use clock
	1	Use clock

Change date/time (Ex. 2000/1/11 13:10:01)		
▲: Increase of no. ◀: Shift of digit ENTER: Store and move into next menu	LED Display	Meaning
	C1 98	Year : 00
	C2 12	Month : 01
	C3 11	Day : 11
	C4 13	Hour : 13
	C5 10	Minute : 10
	C6 01	Second : 01

SERIAL INTERFACE

OP-1 RS-232C Serial Interface (COM1)

Transmit mode: RS-232C interface

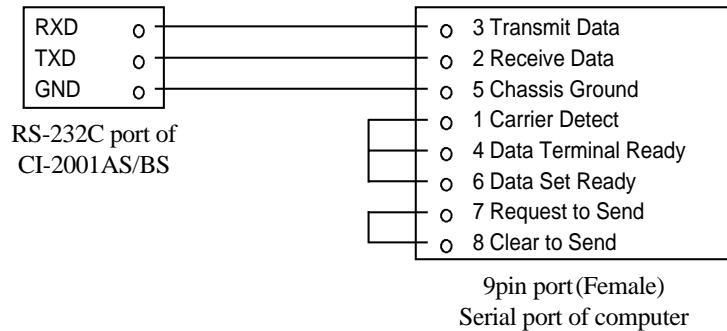
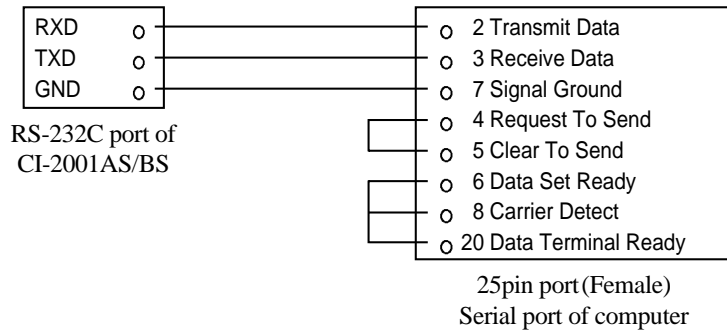

Sub-display Connection

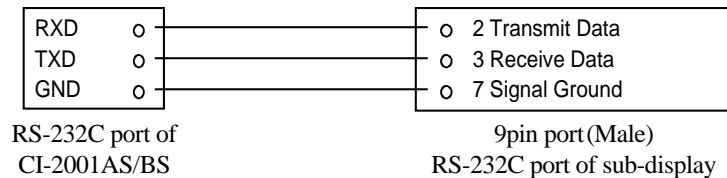

Transmit Data Format (22 bytes)

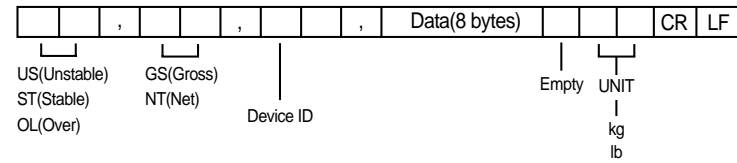

Device ID

Transmit 1 byte device ID so that the receiver can receive data selectively which indicator send.
(Device ID is able to set at F10.)

Data(8 bytes) : Weight data with decimal point

1. 13.5 kg : '0', '0', '0', '0', '1', '3', '.', '5'
2. 135 kg : '0', '0', '0', '0', '1', '3', '5', '0'
3. -135 kg : '-', '0', '0', '0', '1', '3', '5', '0'

Each ASCII code of weight transmitted by 8 byte. ('0' : 0 × 20)

Simple Interface Program (Language : BASIC)

```

10 OPEN "COM1:9600,N,8,1" As #1
20 IF LOC(1) = 0 THEN 60
30 A$ = INPUT$(1,1)
40 PRINT A$ ; ",";
50 GOTO 20
60 B$=INKEY$ : IF B$ =" " THEN 20
70 PRINT B$ ; ",";
80 PRINT #1,B$;
90 GOTO 20
    
```

■ Simple Interface Program (Language C)

```
#include <bios.h>
#include <conio.h>

#define COM1      0
#define DATA_READY 0x100
#define TRUE      1
#define FALSE     0

#define SETTINGS  0xE3

int main(void)
{
    int in, out, status, DONE = FALSE;

    bioscom(0, SETTINGS, COM1);
    cprintf("... BIOSCOM [ESC] to exit ... \n");
    while (!DONE)
    {
        status = bioscom(3, 0, COM1);
        if (status & DATA_READY)
            if ((out = bioscom(2, 0, COM1) & 0x7F) != 0)
                putchar(out);
        if (kbhit())
        {
            if ((in = getch()) == '\x1B')
                DONE = TRUE;
            bioscom(1, in, COM1);
        }
    }
    return 0;
}
```

■ ND Series serial printer connection

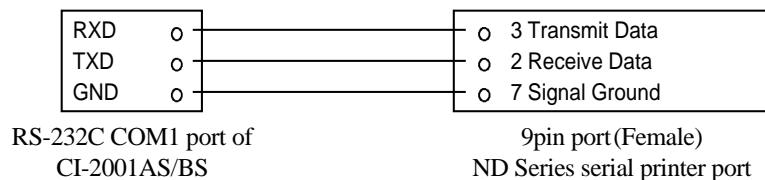

Option	RS-422/485 Serial Interface (COM1)
--------	------------------------------------

- Transmit mode: Same as RS-232C interface COM1
- Data format: Same as RS-232C interface COM1
- Connecting method of RS-485 port

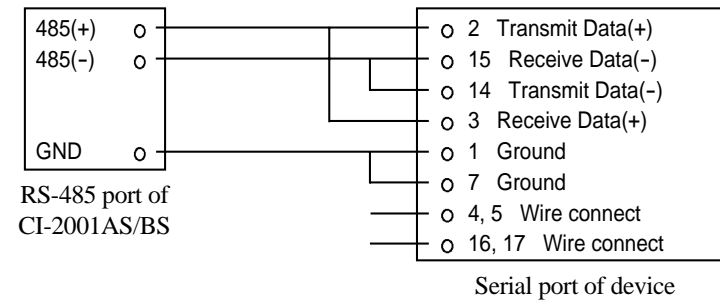

■ Connecting method of RS-485 remote sub display

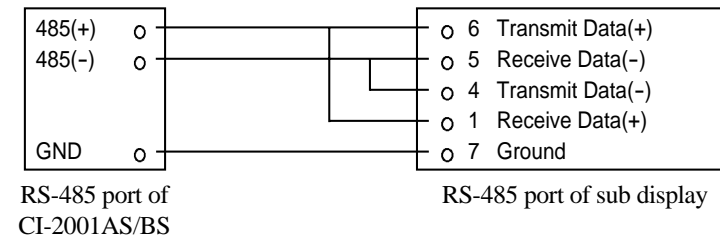

ERROR MESSAGE & TROUBLE SHOOTING

1. Errors in Weighing Mode

Err 02

- Reason: Load cell connection failure or error in A/D conversion part.
- Trouble shooting: Check the load cell connector to see if the polarity of signal is reversed.

Err 06

- Reason: Error in printer connection
- Trouble shooting: Check with printer connector.
If there is no problem with printer and printer connector, please request A/S to head office.

Err 08

- Reason: The ZERO key or TARE key is adjusted not to be operated under the unstable condition.
- Trouble shooting: Press zero or tare key in stable condition.

Err 10

- Reason: Tare weight exceeds the maximum capacity of the scale.
- Trouble shooting: Set the tare to be smaller than the maximum capacity. Otherwise the maximum capacity is reset to be larger than the tare to be set in the calibration menu, and reset the calibration using weight.

Err 13

- Reason: The zero range deviates from the set range.
- Trouble shooting: Confirm that there is nothing on the weighing platform. If nothing exist, do calibration in CAL mode.

Over

- Reason: The weight on platform is too heavy to be measured.
- Trouble shooting: Do not load the item exceeds the maximum tolerance. If the load cell is damaged, the load cell should be replace.

2. Errors in Calibration Mode

Err 21

- Reason: The resolution is set to be exceeded the limit 1/50,000.
- Trouble shooting: Lower the resolution.
The resolution = allowed weight/one division
Modify the allowed weight in CAL 1 or modify the division in CAL 2 so that the resolution should be below 1/50,000.

Err 22

- Reason: The weight for span calibration is set to be lower than 1% of the maximum capacity of the scale.
- Trouble shooting: Set the weight for span calibration in CAL 3 to be more than 10% of the maximum capacity.

Err 23

- Reason: The weight for span calibration is set to be exceeded 100% of the maximum capacity of the scale.
- Trouble shooting: Set the weight for span calibration to be within the maximum capacity of the scale in CAL 1.

Err 24

- Reason: The load cell output is too small at SPAN calibration.
- Trouble shooting: Setting of current resolution is not possible due to the error in load cell. Proceed calibration again with less resolution.

Load cell sense voltage for 5V excitation voltage	Recommended resolution
2mV	1/1,000
4mV	1/2,000
10mV	1/5,000

Err 25

- Reason: The load cell output is too large at SPAN calibration.
- Trouble shooting: Setting of current resolution is not possible due to the error in load cell. Proceed calibration again with less resolution.



Err 26

- Reason: The load cell output is too large at ZERO calibration.
- Trouble shooting: Check whether the platform empty.
Proceed calibration again after checking in A/D TEST mode.



► Notice: Specifications are subject to change for improvement without notice.