

DES-B

Truck and Tank Weighing Load Cell



P/F

Tank

Truck

LOAD CELL

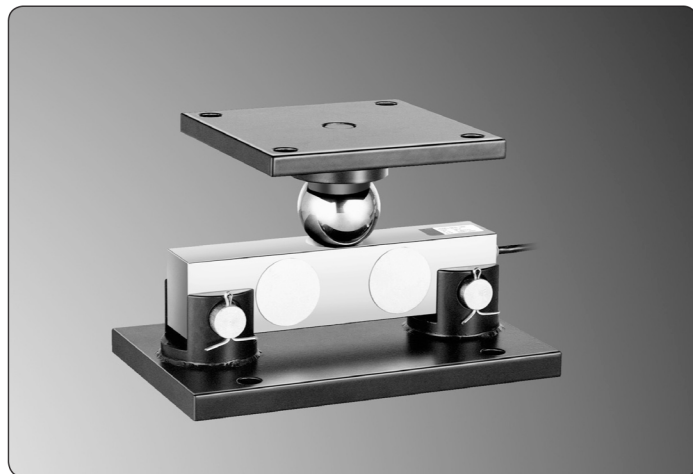

DIMENSION

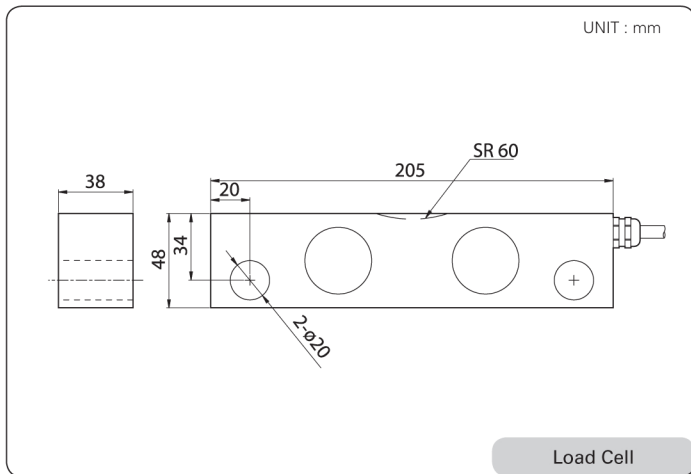

FEATURES

- Steel construction
- Robust design and installation
- Strong against shock or side force
- Low price
- Compact size
- Designed according to IP67

ACCESSORY FEATURES

- Easy Load Cell replacement
- Appropriate for tank and plat form application
- High resolution by use of ball
- Designed for safety

MANUAL

- Check the Load Cell level with the surface
- Do not apply an excessive force to remove the snap ring

ACCESSORY OPTION

- Accessory (Set)

SPECIFICATION

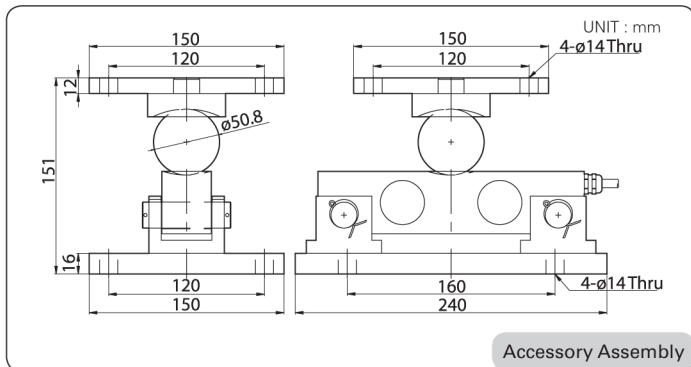

Capacity		tf	5, 10, 15
Rated Output		mV / V	2.0 ± 0.004
Zero Balance		mV / V	0.0 ± 0.02
Accuracy Class		-	D3
Non-Linearity		% R.O.	≤ 0.03
Hysteresis		% R.O.	≤ 0.03
Combined Error		% R.O.	≤ 0.03
Repeatability		% R.O.	≤ 0.02
Creep for 30min.		% R.O.	≤ 0.03
Return for 30min.		% R.O.	≤ 0.03
Resolution		-	≤ 1/3000
Division		mV / V	0.00067
Temperature Effect on	-Zero Value	%/10°C	≤ 0.03
	-Output Value	%/10°C	≤ 0.015
Excitation	-Recommended	V	10
	-Maximum	V	15
Resistance	-Input	Ω	800 ± 40
	-Output	Ω	700 ± 7
	-Insulation	MΩ	> 2000
Compensated Temperature Range		°C	- 10 to + 40
Operating Temperature Range		°C	- 20 to + 80
Material & Plate		-	Steel, Plate
Cable Specification		-	Ø5 x 4P x 10M (P.V.C)
Safety Overload		% R.L.	150% R.L.
Platform Size		mm	No Platform type