

NO.	DESCRIPTION	MATERIAL	DIMENSION	QUANTITY	REMARK
1	MOTOR	-	1.1KW x 6P	1	
2	FAN	AL-ALLOY	ø800	1	
3	FILLER	PVC	0.25t	1 SET	
4	CASING & LOUVER	F.R.P	4.0t	1 SET	

DESIGN SPECIFICATION

WATER FLOW RATE	39	m <sup>3</sup> /hr
INLET WATER TEMP.	37	°C
OUTLET WATER TEMP	32	°C
WET BULB TEMP.	27	°C
WATER INLET	80 A x 1 EA	
WATER OUTLET	80 A x 1 EA	

LOAD DATA TABLE

NET WEIGHT	341	kg
OPERATING WEIGHT	1,070	kg

CONC. FOUNDATION DIMENSION (S:1/40)

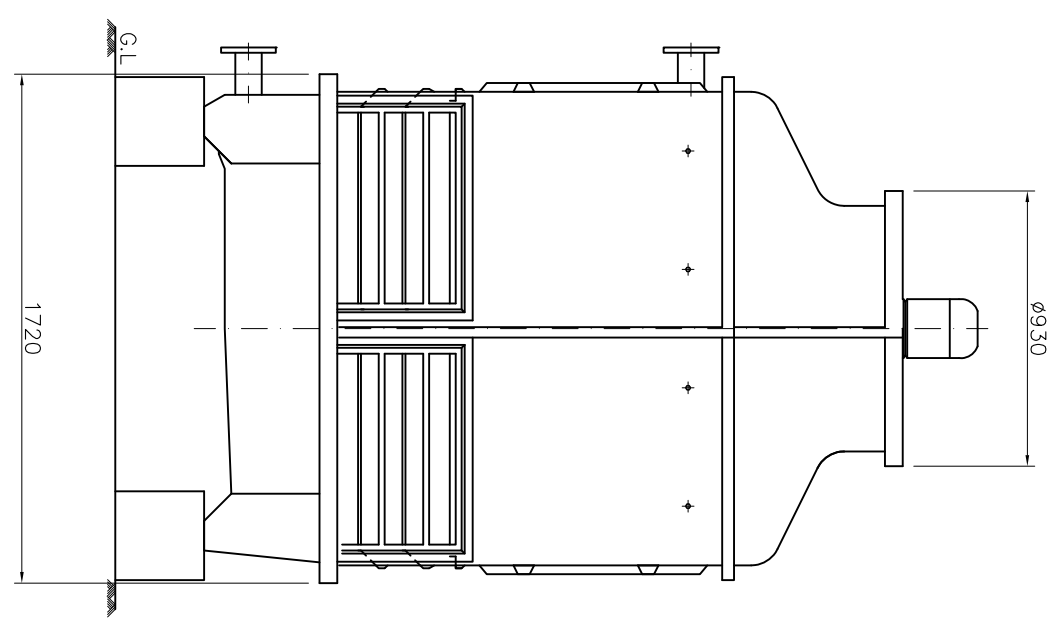
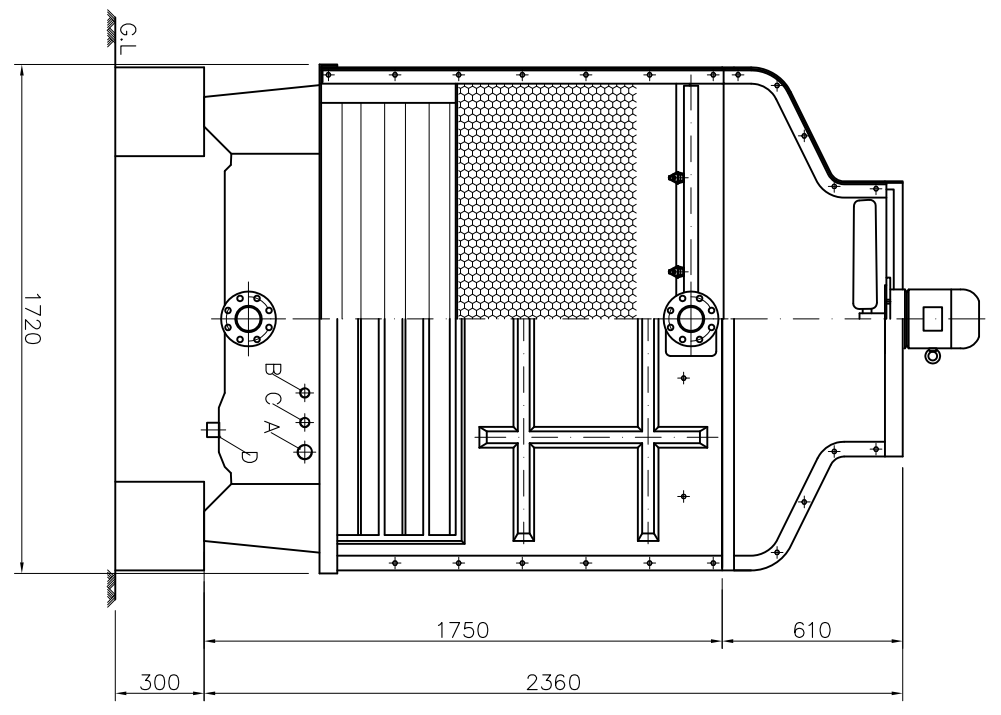
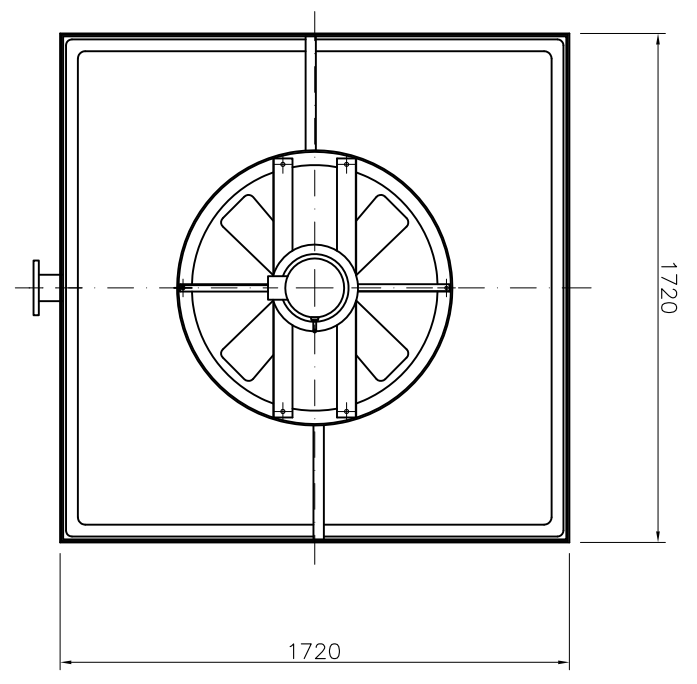
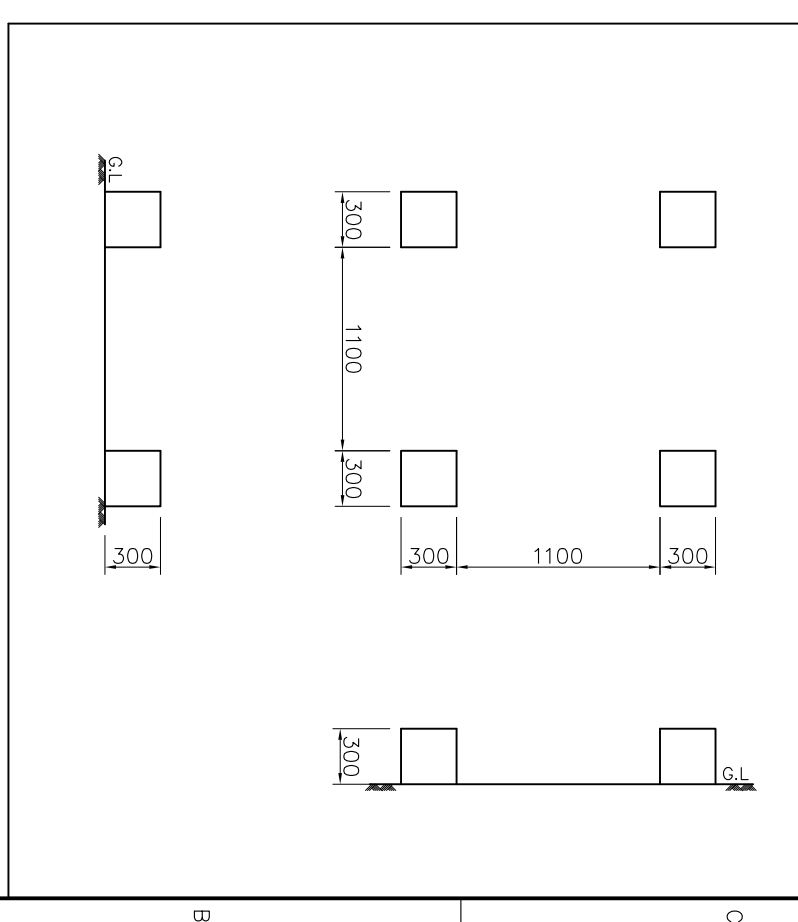

NO.	DATE	DESCRIPTION	DRN	DGN	CHK	APP
△						
△						
△						



**동해공업(주)**  
DONGHAE INDUSTRIAL CO., LTD.

TITLE	COUNTER FLOW PACKAGE TYPE	SCALE	1 / 25
MODEL NO.	XT-50	UNIT	METRIC
DWG NO.	XT-050-00	PROJECTION	1st Angle