

ITEM NO.	PART NAME	MATERIAL
101	Casing	GC200
102	Impeller	GC200
103	Bracket	GC200
104	Bearing Housing	GC200
201	Shaft	SM45C
202	Packing Gland	GC200
203	Bearing Cover	GC200
301	Suction Flange	GC200
302	Discharge Flange	GC200
303	Flap Valve	NBR
401	Ball Bearing	STB
402	Gland Pcking	GREASE PAKING
403	Deflector	NBR
404	Impeller Nut	SS400
405	Impeller Key	SM45C
501	M/S	-
502	M/S Cover	GC200

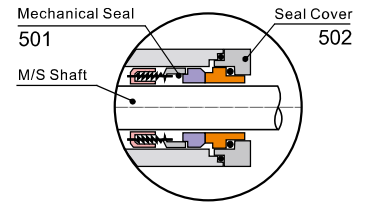

Mechanical Seal (Option)

Outline Drawing

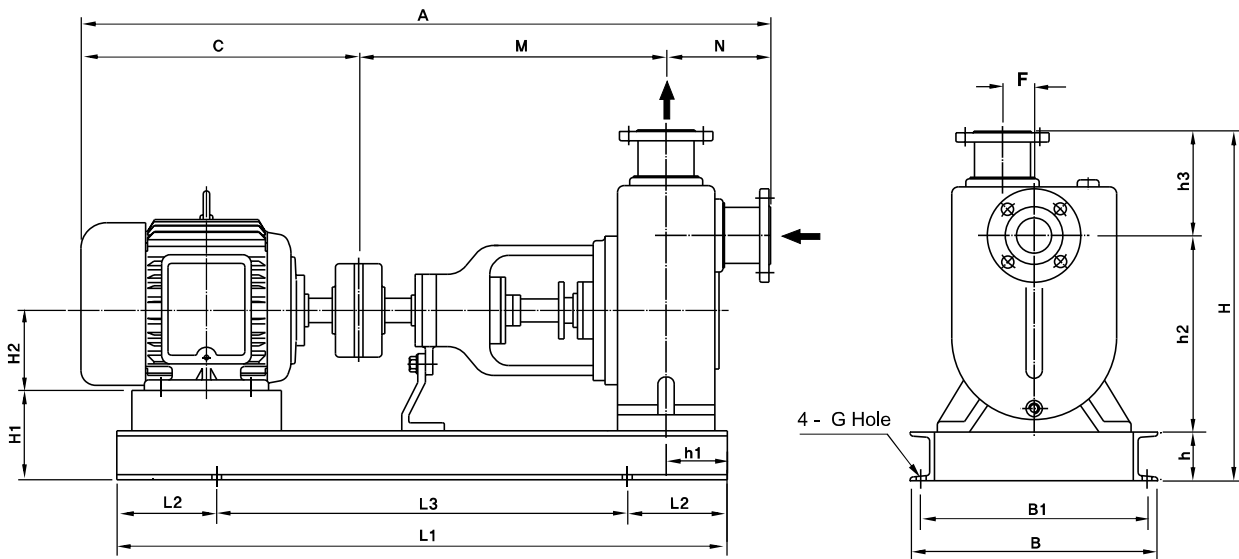

Flange Type

Unit:mm

구분 펌프형식	흡입 (Suc.)	토출 (Dis.)	동력 (kW)	DMC 외형치수 (Outline Dimensions)															
				A	C	M	N	L1	L2	L3	B	B1	H	h	h1	h2	h3	F	G
DSP 40	40	40	0,75	784	284	300	200	600	120	360	200	170	400	75	50	190	135	45	M16
DSP 50	50	50	1,5	785	330	310	145	630	120	390	210	180	439	75	50	208	156	50	M16
DSP 65	65	65	2,2	840	350	335	155	700	120	460	240	210	450	75	50	215	160	50	M16
DSP 80	80	80	3,7	890	385	340	165	730	120	490	265	235	495	75	65	205	215	80	M16
DSP 100	100	100	7,5	890	385	340	180	730	120	490	265	235	550	75	60	273	202	80	M20
DSP 125	125	125	7,5	1175	476	500	200	980	150	680	360	320	640	125	60	245	270	80	M20
			11	1265	565	500	200	1100	150	800	360	320	640	125	60	245	270	80	M20
DSP 150	150	150	15	1474	639	585	250	1250	200	850	380	350	785	125	90	372	288	80	M20