

SMART Gas Detector/Transmitter(4~20mA) with built-in LCD

DA-50



Best Detectors, Best Service



C-910C, Bupyeong Woolim Lion's Valley,
#425, Cheongcheon-Dong, Bupyeong-Gu, Incheon, Korea
TEL: +82-32-623-7507 FAX: +82-32-623-7510
E-mail: sales@gasdna.com | Web: www.gasdna.com

Contents

■ Introduction -----	3
■ Features -----	3
■ Specification -----	4
■ Operation keys -----	5
■ Sensor calibration -----	6 ~ 7
■ Sensor replacement -----	7
■ Wiring -----	8
■ Dimension -----	8
■ Installation -----	9
■ Programming -----	10 ~14

[Introduction]

DA-50 detects various combustible & toxic gases leaked from industrial areas for gas producers, gas users, gas reservoirs, gas by-producers, and so on, in order to prevent any accidents in advance.

DA-50 converts digital signal into the 4-20^{mA} standard current signal for output signal which can be transmitted to various external devices such as PLC, DDC, RECODER, and so on. Using these functions, you can easily construct the gas monitoring system more extensive as well as more comprehensive.

DA-50 provides RS-485 communication signal and gas leakage alarm signal by relay contact output. Besides, DA-50 has DC 4-20mA standard output which realizes max 2500m long distance output signal transmission from sensor to receiver and RS-485 communication signal which realizes max 1000m long distance signal transmission.

[Features]

◆ Digital Process

Digital process based on built-in micro processor realizes various artificial intelligent functions which result in more convenient, more accurate, and more efficient gas detection environment.

◆ Polycarbonate Housing

Polycarbonate housing which has corrosion proof material and water proof structure is the best application to detect corrosive gas.

◆ Self Diagnosis

Digital processor automatically diagnoses the sensor signal and sends 2mA error signal output on the malfunction in the sensor.

◆ LCD display with Back Light

LCD offers real-time display of gas density and back light offers easy reading even in dark area.

◆ User Programmable Menu

User programmable calibration density and detection range offers user's own operating functions.

◆ Multi Signal Output

Various output signals - DC 4-20mA, 2 step-relay contact, & RS-485(option) – provides best networking with all kinds of devices & equipments.

June 12, 2012

◆ 4-20mA Transmitter

4-20mA output enables stable and long distance (maximum 2.5km) signal transmission.

◆ RS-485

RS-485 enables stable and long distance (maximum 1.2km) signal communication.

◆ Alarm output

SPST 2 step relay contacts (AL1/AL2).

[Specification]

Detection principle	Catalytic, electro-chemical, NDIR, or PID
Gas sampling	Diffusion
Target gas	Refer to the list
Density indication	LCD display - PPM, %LEL, or %
Response time	Within 20 seconds, 90% / full scale
Accuracy	$\leq \pm 2\%$ / full scale
Sensor calibration	Calibration with switch
Sensor parallax	Zero – $\leq \pm 1\%$ / 6 months, Span – $\leq \pm 1\%$ / 6 months
User programmable	Calibration density, detection range
Input power	DC 20 ~ 30V
Output power	4 ~ 20mA / full scale – maximum 2.5km long signal transmission
Communication	RS-485 – maximum 1.2km long signal transmission with GasDNA's own protocol
Operating temperature and humidity	-20°C ~ 50°C, 5~95% RH (non-condensing)
Signal wire	CVVS & CVVSB 1.25sq x 3 wires - shield type
Alarm release	Manual or Automatic
Mounting	Wall or pipe mounting
Housing	Polycarbonate
Alarm output	2 step- relay contacts (AL1/AL2)

[Operation Keys]

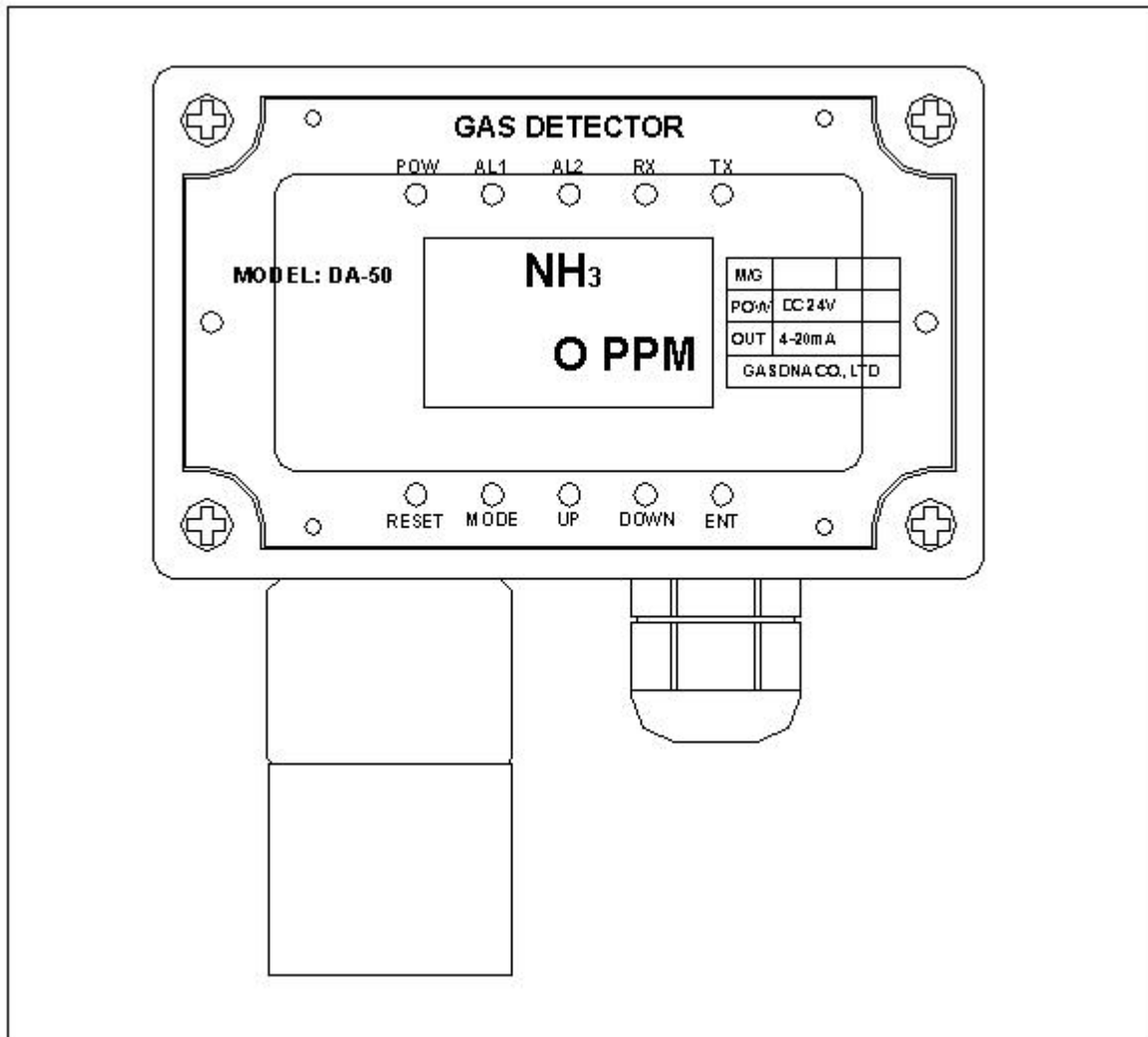

Keys	Description
RESET	Release the alarm relay. <ul style="list-style-type: none"> - When AL1 or AL2 relay operates, you can release it (In manual mode) (ex) If you set manual mode in AL-RESET menu, <ol style="list-style-type: none"> (1) When the measured value is lower than AL1 value, AL1 relay off. (2) When the measured value is higher than AL1 value, AL1 relay on.
MODE	<ul style="list-style-type: none"> - Enter into setting mode from measuring mode. - In setting menu, move to other setting menus.
UP	Increase the setting value <ul style="list-style-type: none"> - When you keep touching it more than 5 seconds, the setting value increase very fast.
DOWN	Decrease the setting value

	- When you keep touching it more than 5 seconds, the setting value decrease very fast.
ENT	Restore the set value
POW	Power on.
AL1	AL1 operates.
AL2	AL2 operates.
RX	RS-485 receives signal.
TX	RS-485 sends signal.

[Sensor Calibration]

Gas sensor's property is subject to change while it is being used. This is common to all sensors. You have to calibrate the sensor periodically to keep the optimum condition of sensor.

DA-50 has automatic calibration function by micro processor.

1. Zero calibration

Please follow below process to zero-calibrate sensor output.

- ① Please keep touching the **MODE** key more than 2 seconds through glass window and enter into setting mode.
- ② Then, LCD shows "CAL-[ZERO]". Please touch **ENT** key.
- ③ Then, LCD shows "ZERO GAS". Please infuse the standard gas.
- ④ When the measured value gets stable, please touch **ENT** key.
- ⑤ Then, if zero calibration is successful, LCD shows "[OK]".

▲ **Caution:** For zero calibration, you should have clean status without any gases. If you cannot have clean status, please use nitrogen gas for zero calibration.

2. Span calibration

Please follow below process using standard gas to calibrate the linear change of sensor output.

- ① Please assemble calibration nipple on sensor cap.
- ② Then, please touch **MODE** key more than 2 seconds after disassembling main cover. It leads you to setting mode.
- ③ Then, please move to "CAL [SPAN]" menu and touch **ENT** key.
- ④ Then, LCD shows "SPAN-ADJ". Please input desired calibration gas density values touching **UP** & **DOWN** keys. When you finish it, please touch **ENT** key. (gas density set finished)
- ⑤ Then, LCD shows "SPAN-GAS". Then, please infuse the calibration standard gas. While you infuse the gas, LCD values approaches the values of gas density. When the LCD shows stable gas values, please touch **ENT** key. (span calibration finished).

June 12, 2012

- ⑥ Then, please stop infusing the gas and disassemble the calibration nipple while LCD values gets less and shows "Holding PPM" finally.
- ⑦ After 3 minutes when an LCD value gets less than 9 PPM, it automatically enters into measuring mode. (Or when LCD value gets less than 9 PPM, you can touch RESET key to enter into measuring mode)

▲ Caution: Span calibration gas should be ranged from 5ppm to 90ppm. Sensor calibration is not possible with high density gas. High density gas puts excessive burden to the sensor and it damages the sensor or reduces the sensor life time extremely.

▲ Caution: For calibration after sensor replacement, please wait 10 minutes from power on.

[Sensor Replacement]

DA-50 has sensor cap & sensor filter in order to protect sensor. This sensor cap composes of two modules for easy disassembly. Please follow below steps for sensor replacement.

- ① Please make sure of power off to DA-50.
- ② Please open the cover of DA-50.
- ③ Please unscrew the two bolts fixing the display board and disassemble the display board.
- ④ Please disassemble the 3 wire connector which connects the sensor and sensor board.
- ⑤ Please rotate the sensor cap counterclockwise and detach the sensor cap.
- ⑥ Please rotate new sensor cap clockwise and fix it.
- ⑦ Please connect the 3 wire connector between sensor and sensor board.
- ⑧ Please fix the display board screwing the two bolts.
- ⑨ Please fix the four nuts on the cover of DA-50
- ⑩ Please power on.
- ⑪ Please do sensor calibration.
- ⑫ After sensor calibration, measuring mode automatically starts.

▲ Caution

- Please make sure of power off to DA-50 before sensor replacement or display board disassembly.
- If the direction of sensor cable connector is different with sensor board connector socket, both can not be assembled.
- Please fix the sensor cap and main cover tightly to keep water proof structure.

[Wiring]

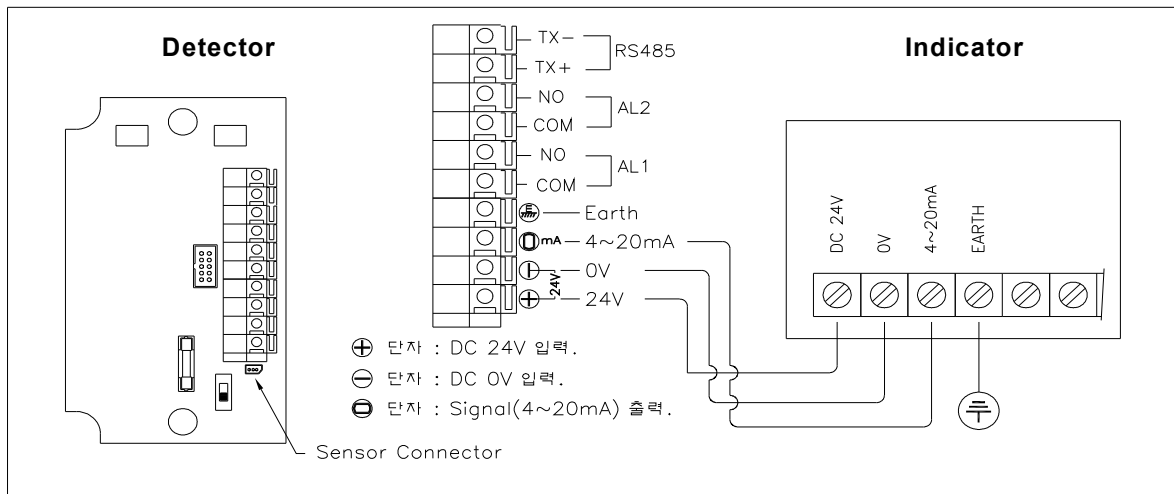

[Dimension]

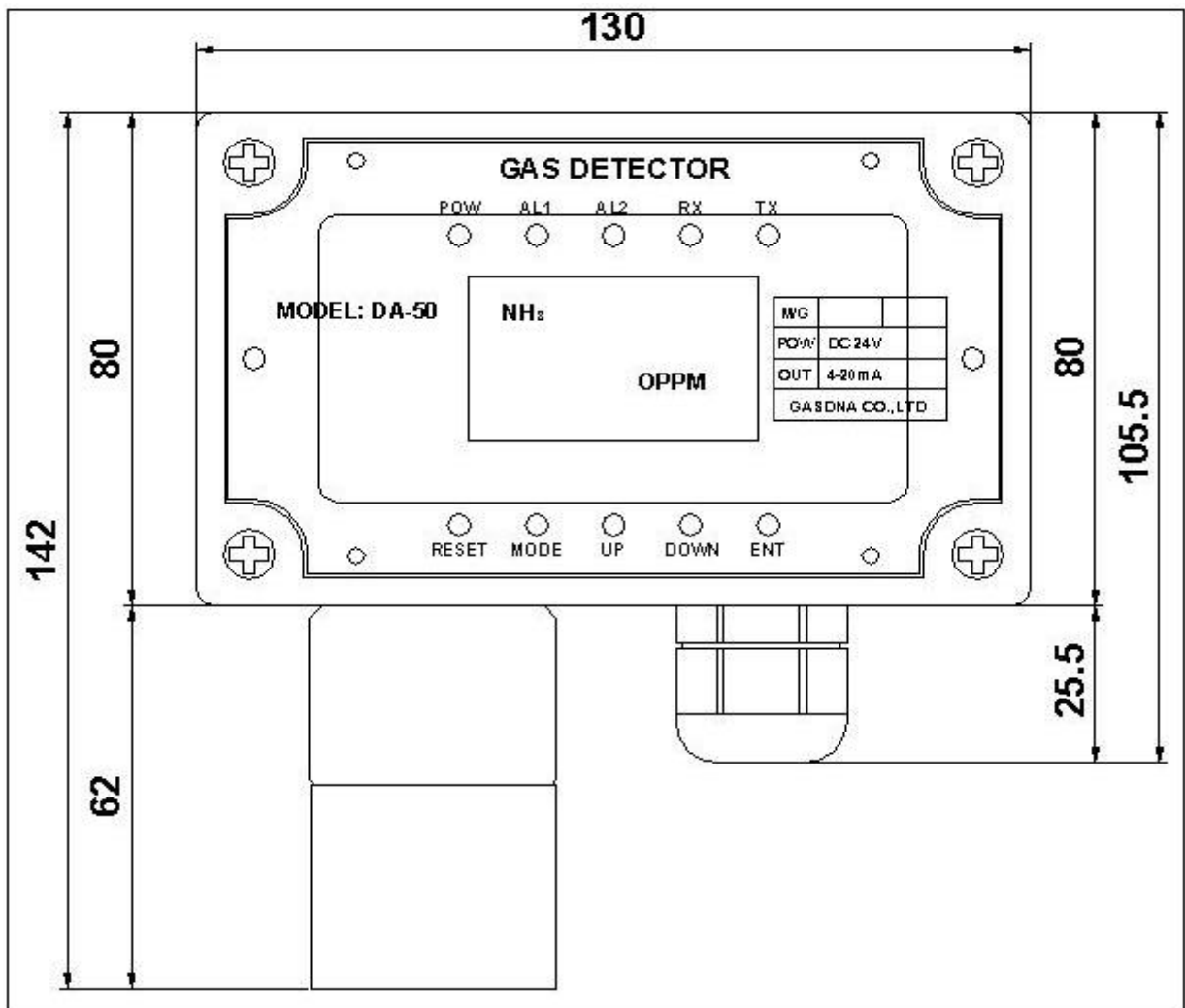

[Installation]

1. Place

- 1) Horizontal: Close to the highly suspected place for gas leakage, such as gas valve and connection of gas pipe considering weight and stay of gas.
- 2) Vertical: Considering the specific gravity of target gas (air = 1),
 - ▷ Light gas (specific gravity is less than 1): Please install the sensor 20 – 30cm from ceiling in closed room. If it is open area, please install the sensor high and closest as possible to the suspected point for gas leakage.
 - ▷ Weight gas (specific gravity is more than 1): Please install the sensor 20 – 30cm from the floor. If it is open area, please install the sensor low and closest as possible to the suspected point for gas leakage.

2. Cautions

- 1) Please avoid vibrating or physical impacting place. Vibration or physical impact can affect the output value.
- 2) Please avoid the high temperate or humid place. High temperate or humidity can result in malfunction.
- 3) Please avoid electronic noise area which has high frequency or high voltage such as motor, pump, or high voltage power cable.
- 4) Please secure enough space for convenient maintenance. As DA-50 needs periodical maintenance and calibration, you have to avoid inconvenient place for these jobs. Otherwise, we recommend suction type detector.
- 5) Cable

We recommend shield type cable to prevent external noise and cable duct, conduit pipe, or flexible to prevent external impact. Also, please avoid the junctions between cables. Otherwise, we recommend junction box.

- Cable specification and transmission distance

Transmission distance	0 ~ 500m	501 ~ 1,500m	Over 1,500m
Cable specification	0.75sq	1.25sq	2.0sq

In case of pressure-proof built-in cable package, please choose the cable with proper outer diameter fit in inner size of package and tighten the cable gland sufficiently in order to prevent any inflow of gas or flame.

[Programming]

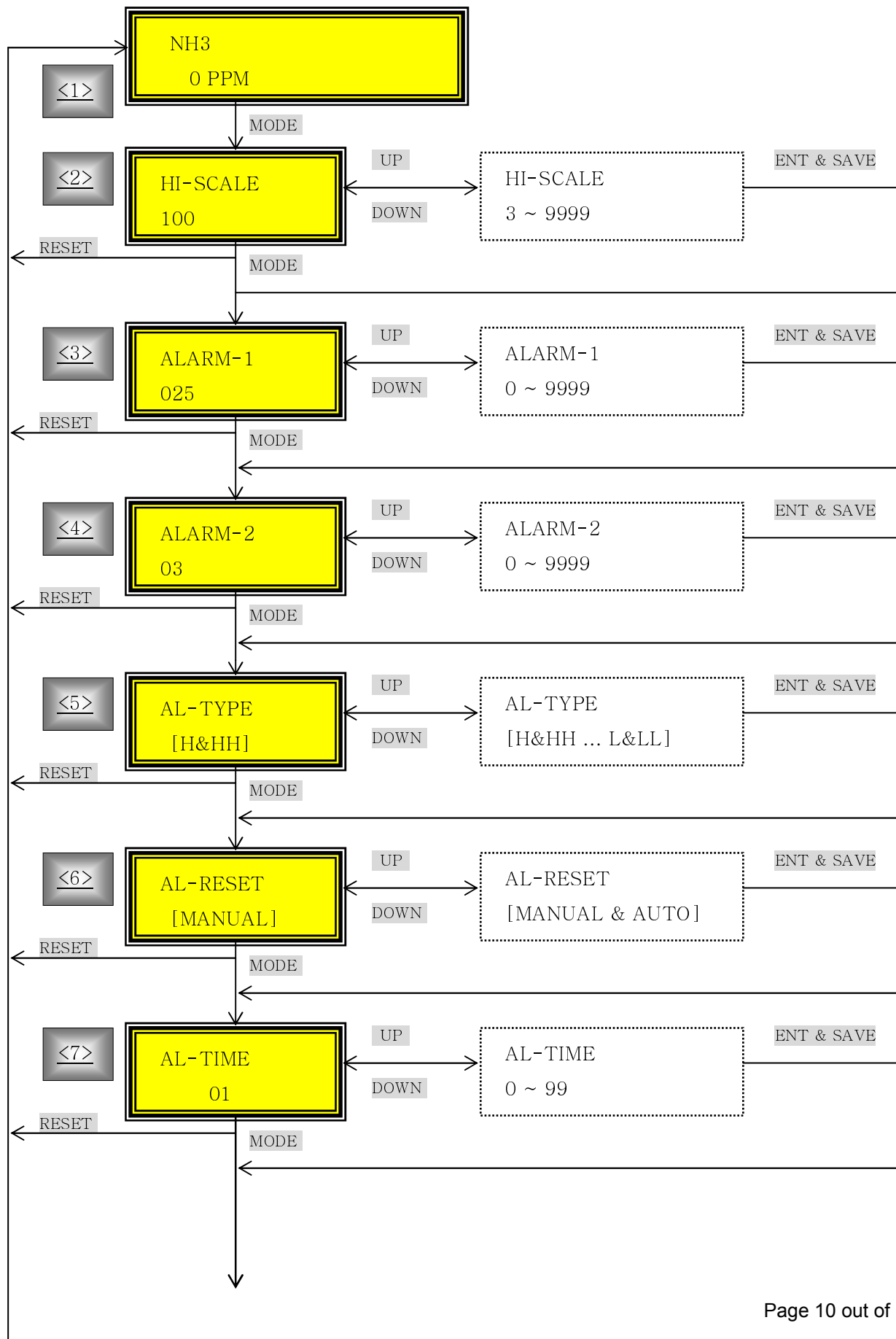

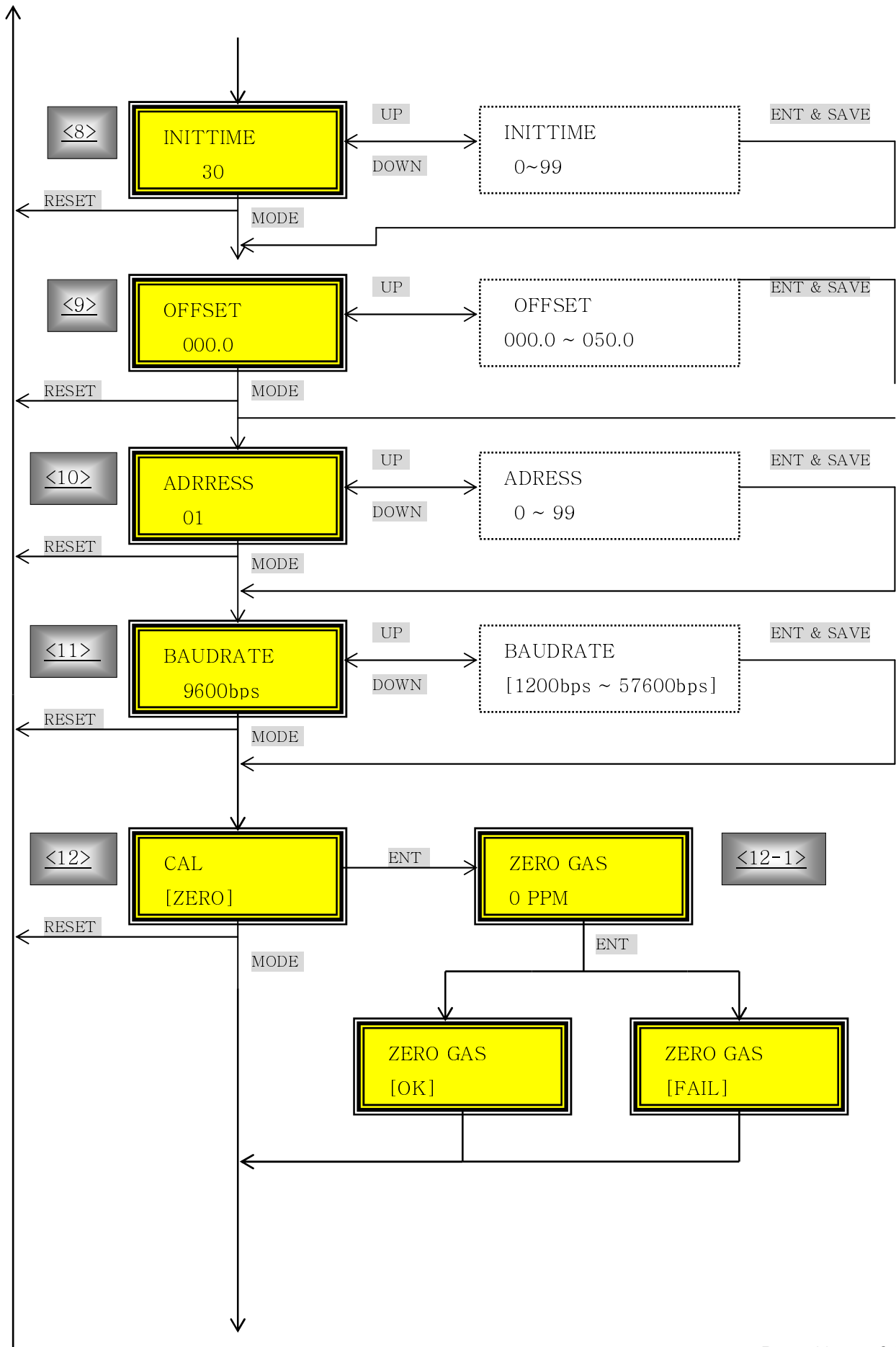

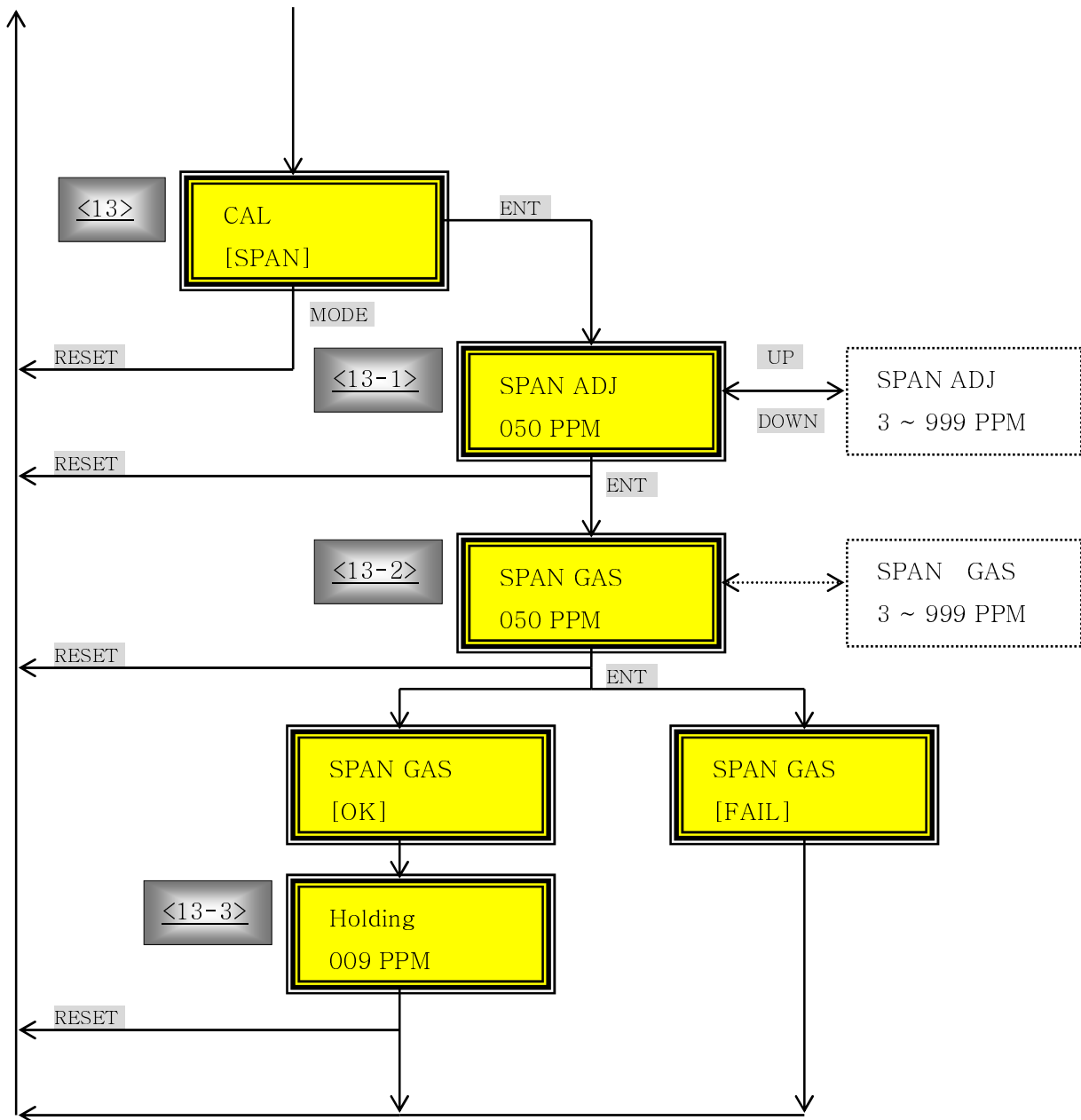

<1> Measuring mode

- LCD shows the gas density.
- If you touch **MODE** key during 2 seconds, you can enter into setting mode.

<2> HI-SCALE

- Full scale = 20mA

(ex) If you set HI-SCALE = 100,

4mA analogue output displays .

12mA analogue output displays .

June 12, 2012

20mA analogue output displays 100.

<3> ALARM-1

- Alarm-1 relay output (You can choose low or high by AL-TYPE setting)

<4> ALARM-2

- Alarm-2 relay output (You can choose low or high by AL-TYPE setting)

<5> AL-TYPE(ALARM-TYPE)

- Four kinds alarm choices: H&HH, H&L, L&H, L&LL

- Alarm relay: ALARM-1 and ALARM-2

ex) If you choose H&L,

→ ALARM-1: High alarm (it operates when measured value goes over the set value)

→ ALARM-2: Low alarm (it operates when measured value goes below set value)

<6> AL-RESET(ALARM RESET)

- Choose Alarm release methods.

- AUTO ↔ MANUAL

(1) AUTO: Without touching RESET key, relay releases automatically when the measured value goes out of alarm range.

(2) MANUAL: With touching RESET key, relay can be released when the measured value goes out of alarm range.

<7> AL-TIME(ALARM TIME)

- Set time of temporary external impact or noise which affects the sensor's normal operation. The detector skips the sensor's temporary abnormal operation during this time.

<8> INITTIME(initialization time)

- Set warming up time. Stable signal output is available after this time from power on.

<9> OFFSET

- Set values to offset the measurement error.

ex) If you set OFFSET = -5,

→ If sensor output = +5, LCD displays 0 after offset by -5.

<10> ADDRESS

- Set RS-485 address.

<11> BAUDRATE

- Set RS-485 baud rate.

<12> ZERO CALIBRATION

In CAL [ZERO], when you touch **ENT** key, LCD shows “ZERO GAS <0.0 PPM>” with random value. Then, please infuse clean air or 100% nitrogen gas into sensor cap. Then, after the LCD value get stable, please touch **ENT** key. Then, LCD shows “ [OK]”.

However, if the calibration is not successful, LCD shows “[FAIL]” during 2 seconds.

<13> SPAN CALIBRATION)

(ex) Target gas : H2S
Standard gas: H2S(25 PPM) + Air Balance

- (1) In CAL [SPAN], please touch **ENT** key.
- (2) Please input H2S standard gas density value using **UP** & **DOWN** key. And then, please touch **ENT** key)

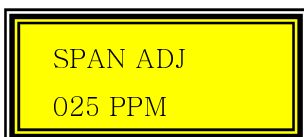

- (3) Please infuse H2S standard gas and wait until LCD value gets stable. After the value gets stable, please touch **ENT** key.

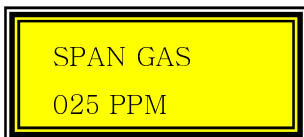

- (4) When span calibration is successful, LCD shows:



- (5) Please eliminate the span gas from gas inlet and wait the LCD value gets less than 10 PPM. When the LCD value goes less than 10 PPM, measuring mode starts automatically.

