

Non contact Temperature + Smoke Detector

TS-60

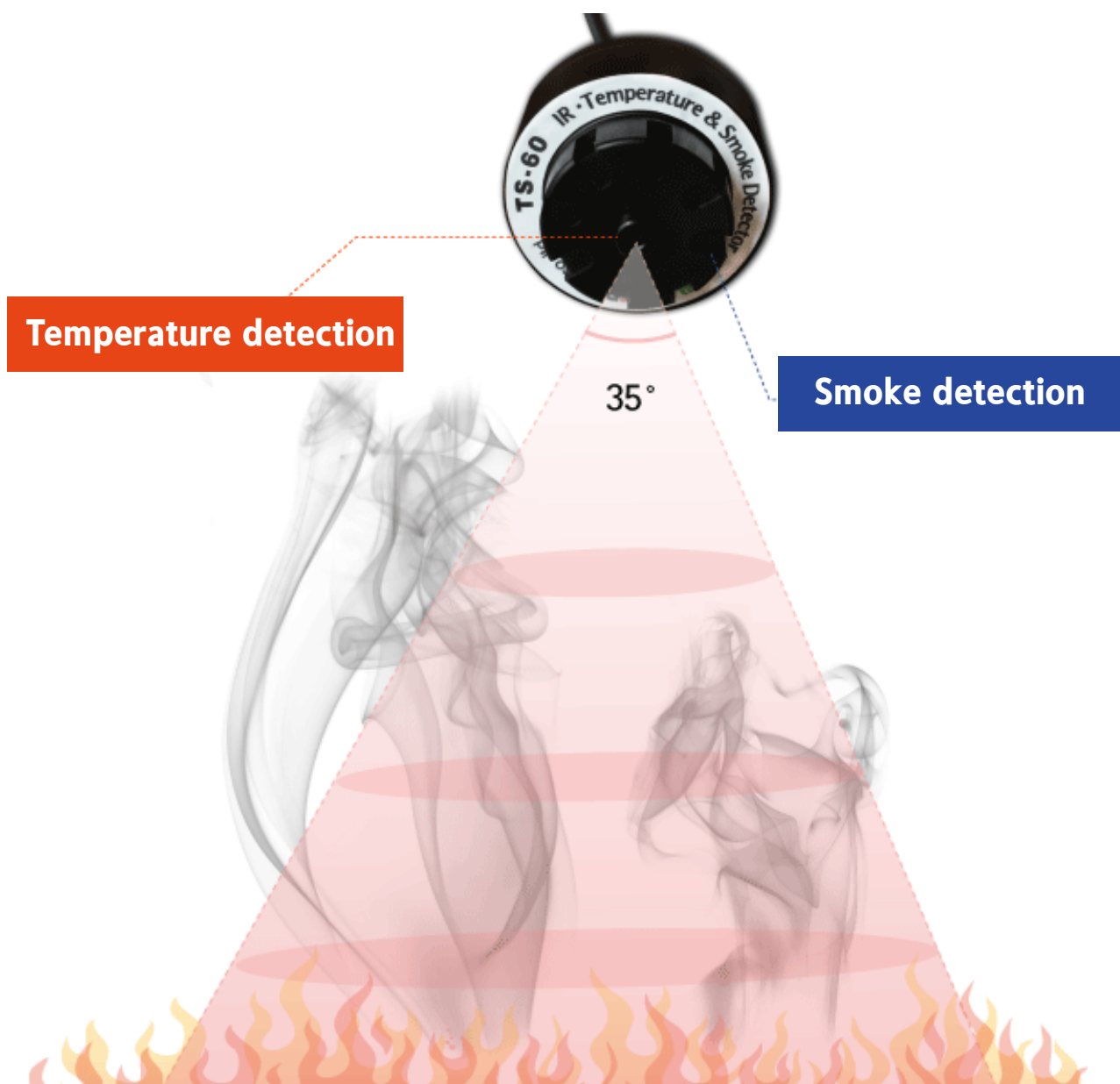

GASDNA co.,ltd

C-910C, Bupyeong Woolim Lion' s Valley,

#425, Cheongcheon-Dong, Bupyeong-Gu, Incheon, Korea

TEL: +82-32-623-7507 FAX: +82-32-623-7510 E-mail: sales@gasdna.com

<http://www.gasdna.com>

[Introduction]

TS-60 is built-in Non contact Infrared thermometer and smoke sensor.

The most of existing temperature and smoke sensors in markets can detect fire after the heat reach to temperature and smoke detector.

However, TS-60 detects the fire by increased infrared amount and low concentrated smoke in early stage of the fire and enables to prevent the fire in advance.

[Features]

_ Non contact Infrared thermometer can measure a wide range of temperature from -70°C to 380°C '

– The user can adjust the alarm temperature by DIP switch

– Low Concentrated Smoke Detection

It is designed to support the safety of industrial automation precision equipments so that it is suitable for low concentrated smoke detection

– Digital Process

Digital process based on built-in micro processor realizes various artificial intelligent functions which result in more convenient, more accurate, and more efficient detection environment.



▲ fire of switchboard _ TS-60 minimize the damage by early detecting of these fire.

[Specification]

	Non contact Infrared thermometer
Measuring Range	-70 ~ 380°C (Alarm value setting by DIP switch)
Device	Thermopile (Non contact Infrared measurement)
Optical Resolution	35°
Optical Spectrum	8~14 μ m
Response time	0.3 sec
Relay Output	Relay A (DC30V 1A)

	Smoke sensor
Detection Principle	Ionizations Smoke Chamber
Detection Method	Diffusion
Response time	Within 3 sec
Relay Output	Relay A (DC30V 1A)
Input power	DC 22V~26V
Current consumption	50mA, Maximum
Operation temperature/humidity	-20°C~ 60°C / 0 ~ 95% RH (Non-Condensing)
Process	Digital Process

Temperature setting in factory : 50°C

Smoke density : 1%

DIP Switch setting (Setting of the alarm temperature value)

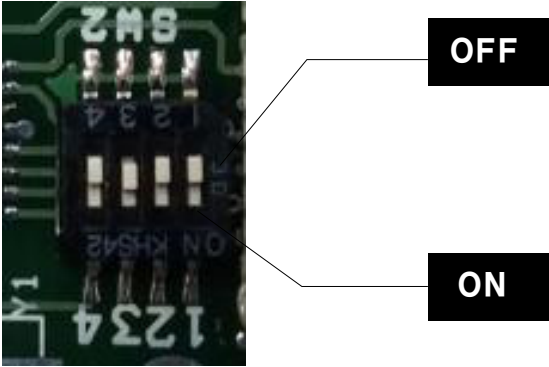

DIP-1	DIP-2	DIP-3	DIP-4	NO	Temperature
ON	ON	ON	ON	0	35
ON	ON	ON	OFF	1	40
ON	ON	OFF	ON	2	45
ON	ON	OFF	OFF	3	50
ON	OFF	ON	ON	4	55
ON	OFF	ON	OFF	5	60
ON	OFF	OFF	ON	6	65
ON	OFF	OFF	OFF	7	70
OFF	ON	ON	ON	8	75
OFF	ON	ON	OFF	9	80
OFF	ON	OFF	ON	10	85
OFF	ON	OFF	OFF	11	90
OFF	OFF	ON	ON	12	95
OFF	OFF	ON	OFF	13	100
OFF	OFF	OFF	ON	14	105
OFF	OFF	OFF	OFF	15	110

[Dimension]

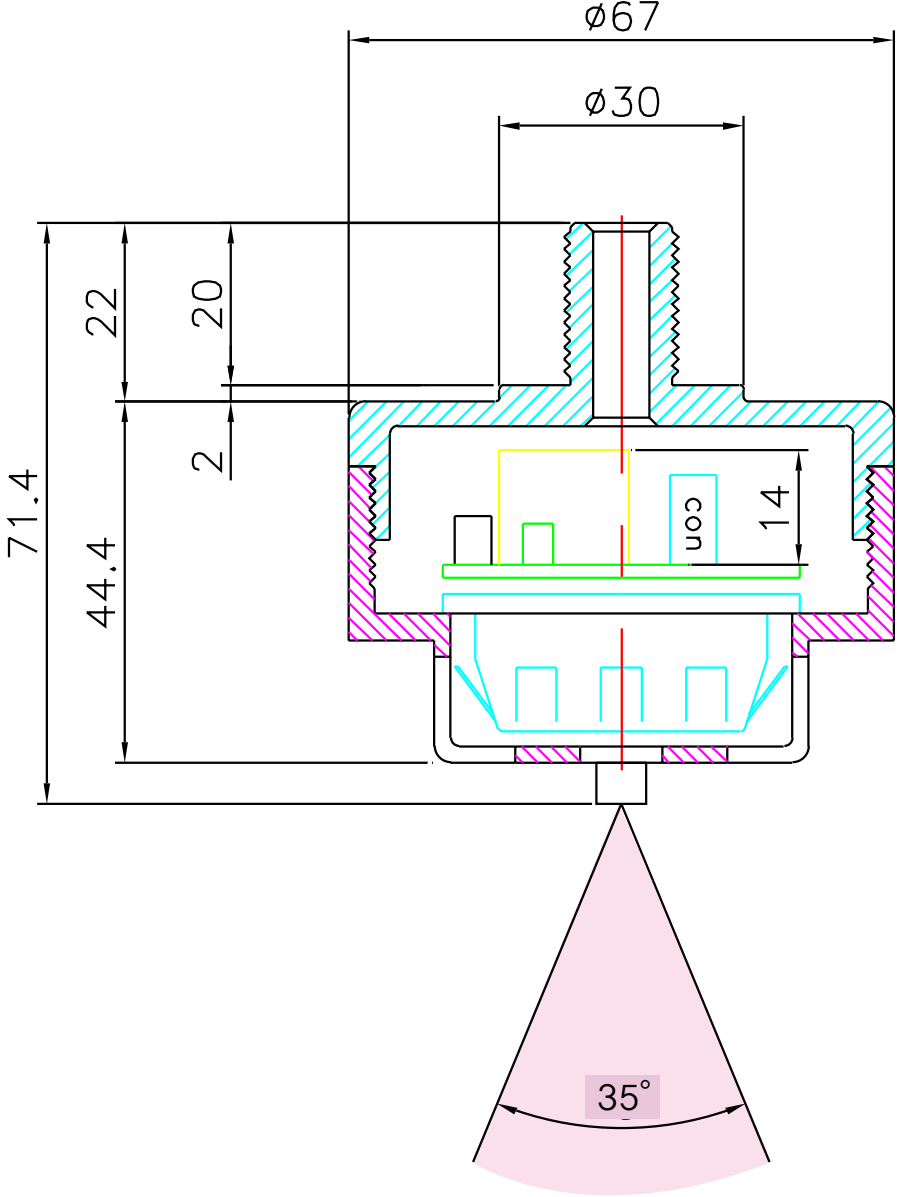

[Wiring]

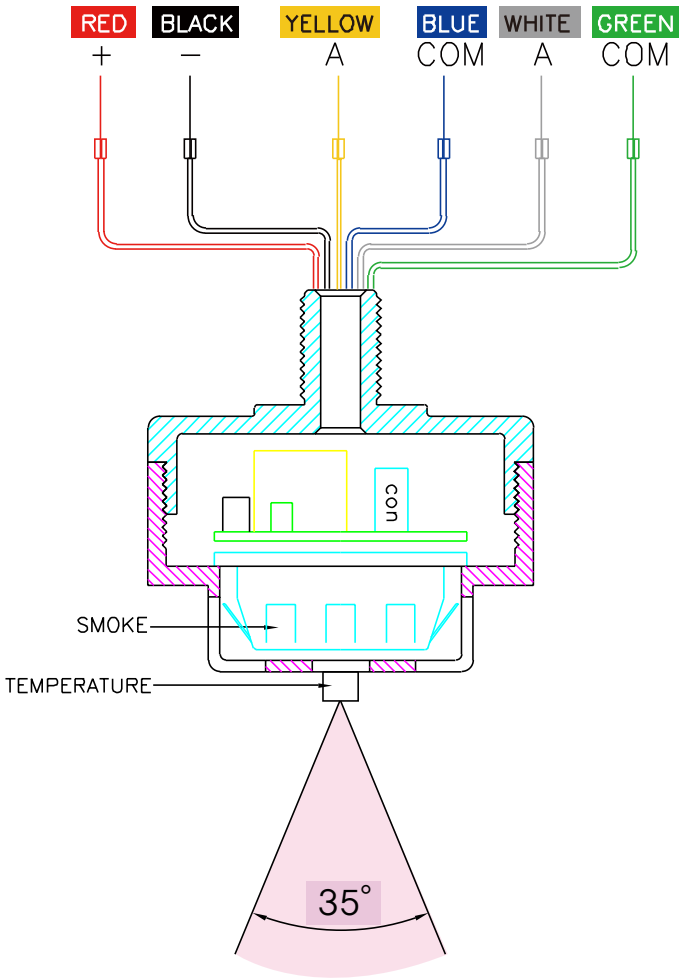

Color	USE		
RED(+)	POWER(+) : 24VDC		
BLACK(-)	POWER(-) : GND		
YELLOW(A)		NO (NORMAL OPEN)	Temperature
BLUE(COM)		RELAY COM	
WHITE(A)		NO (NORMAL OPEN)	Smoke
GREEN(COM)		RELAY COM	

Alarm setting (setting with light bar)

