

# 설치형 적외선 흡입식 가스감지기

## GTD-5000F IR

### 제품의 특징

- ▷ 내압방폭 구조로서 폭발 위험지역에 설치하여 가연성, CO<sub>2</sub>, CO, N<sub>2</sub>O가스를 연속적으로 감지
- ▷ 신기술의 적외선식 측정원리 적용
- ▷ 산소가 존재하지 않은 환경에서도 사용 가능
- ▷ 디지털 Flow Sensor를 적용한 일정한 유량 조절기능 내장
- ▷ 고성능 펌프 내장형으로 가스 누설을 신속하게 감지
- ▷ 마이크로프로세서를 적용한 자기 진단기능 내장
- ▷ 6초 이내의 빠른 응답속도
- ▷ 안정된 품질과 사용 수명이 검증된 감지 원리 적용
- ▷ 마그네틱 바를 이용하여 FND 표시창과 1:1 대화 방식의 원격 교정 및 프로그램 설정
- ▷ 4-Digit 디지털 농도 표시 및 디지털 유량 표시
- ▷ 4-20mA DC 출력 신호
- ▷ RS-485 Modbus (Isolated) Serial 통신으로  
모니터링시스템 구축 용이
- ▷ 3-Wire Type
- ▷ 2단 경보와 1개의 고장 표시 및 릴레이 접점 출력
- ▷ 작업자 1인으로 교정 및 유지보수



## General

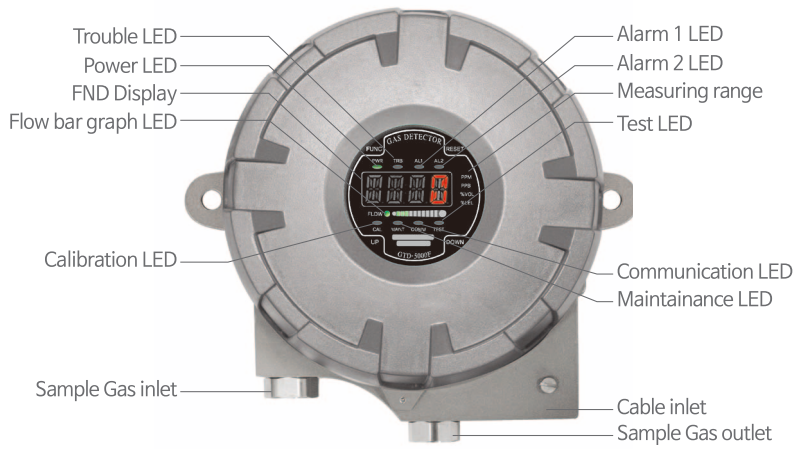

## Dimension (Unit:mm)

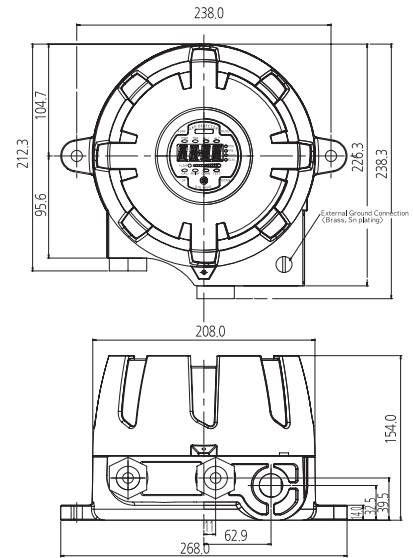

## Accessories



## Specification

※Specifications are subject to be changed without prior notice.

EXPLOSION PROOF & SAMPLING TYPE INFRARED GAS DETECTOR	
Model	GTD-5000F IR
Measuring gas	Hydrocarbon gases (LNG, LPG, Methane, Butane & etc)      CO <sub>2</sub> CO, N <sub>2</sub> O
Measuring type	Auto Sampling type
Measuring method	Infrared type
Measuring range	0~100% LEL    0~5000ppm    0~100% Vol    0-2.0% Vol    0-5.0% Vol, 0~4000ppm
Sensor life time	Over 5 years
Response time	< 6sec / 90% scale, < 3sec / 50% scale
Accuracy	±3% / Full Scale
Parameter control	Non intrusive control with a Magnet bar (calibration, maintenance, alarm setting)
Operation mode display	Alarm / Trouble LED , Flow rate
Measuring value display	FND Display(4-Digit)
Alarm signal output	250V 1A / 3-SPST relay contact (2-stage alarm, 1-trouble)
Output signal	Analog output : 4-20mA DC Digital output : RS-485 Modbus(Optional)
Sampling method	Diaphragm Pump
Sampling line	OD 1/4" (Standard)
Flow rate	0 ~ 1000 ml/min Max
Cable/Distance	Power + Signal cable : 3-wire > 1.5sq(AWG16) 4 - 20mA DC Signal : 500m RS-485 Modbus Signal : 1000m
Conduit connection	M20 x 1.5P, M25x1.5P, NPT 1/2", NPT 3/4"
Mounting type	Wall mount
Operating temperature	-40°C ~ + 60°C
Operating humidity	5 to 99% RH (Non-condensing)
Operating power	Standard : 18 ~31V DC (24V DC normal) / 600mA max
Material	ALDC
Dimensions	226.3(W) × 154(H) × 238(D) mm
Weight	5kg
Approval	Explosion proof type (Ex d IIC T6, IP65) KCs Explosion proof type (EX d IIB + H2 T6, T5) ATEX, IECEx, NEPSI, CE, KFI, KC