



[www.grtec.co.kr](http://www.grtec.co.kr)

A company dedicated to save environment with clean water management

# GREEN TECH PUMP

# GVA

입축 축류 펌프

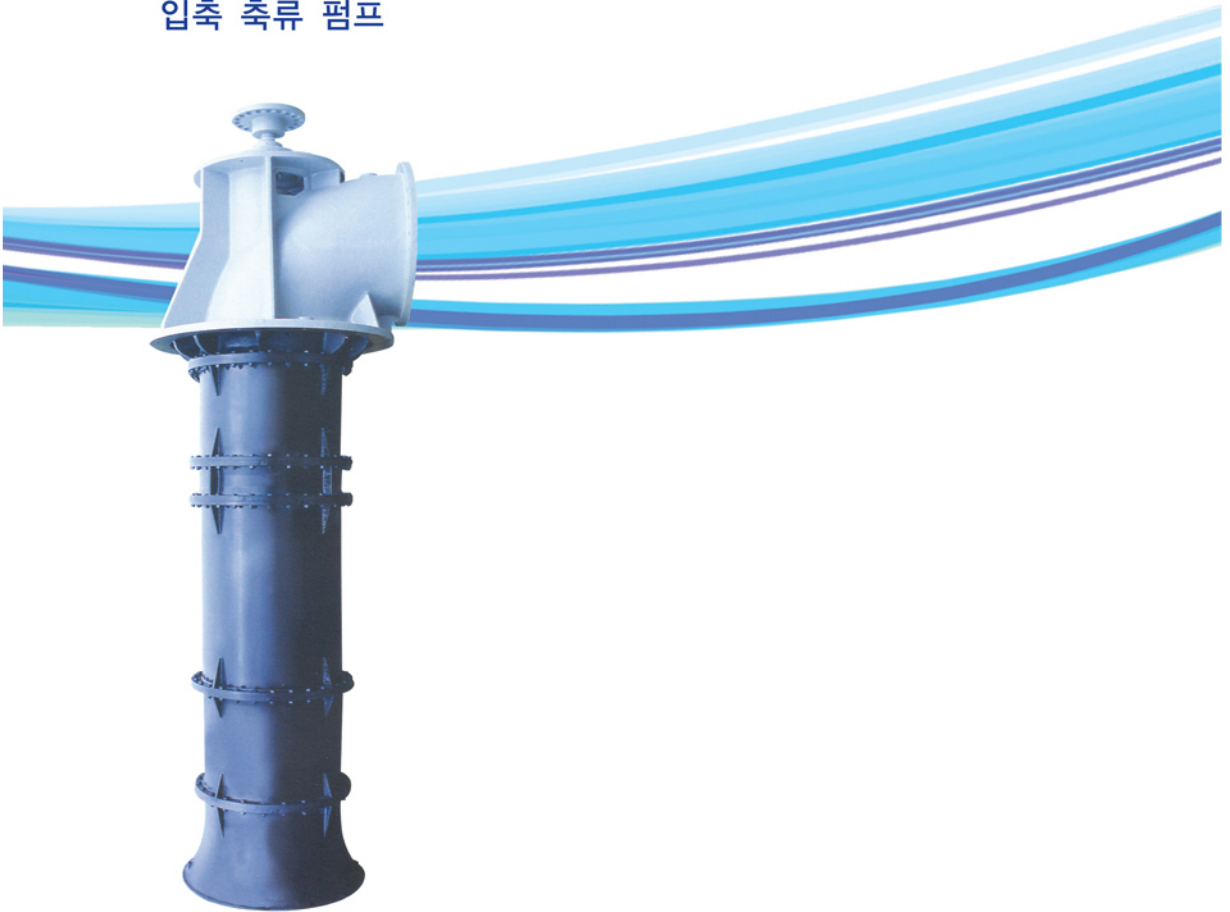

**GREEN TECH Co., Ltd.**  
Pump & System Engineering

## VERTICAL AXIAL FLOW PUMP/ 입축 축류 펌프

### Usages and Applications / 용도 및 적용 분야

- General industries, factory : For water intake, drainage
- Thermal power plant : For cooling water
- Ironworks : For circulation, drainage
- Sewage system : For water influent, effluent
- Water works : For water intake, supply
- Agriculture : For water pumping, drainage
- Others : For drainage of river
- 일반산업, 각종공장 : 취수, 배수
- 화력 발전소 : 냉각용수
- 제철소 : 순환, 배수
- 하수도 : 유입, 방류
- 상수도 : 취수, 송수
- 농업 : 양수, 배수
- 기타 : 하천 배수

### Design & Structure Feature / 설계 및 구조적 특징

- Installation : It has a various installation method to meet customer's requirement
- Rotation : CW viewed from driver
- Flange rating : KS 10Kg/cm<sup>2</sup> FF
- Installation place : Indoor and outdoor
- Sleeve bearing : Rubber (water lubrication), Bronze (grease lubrication)
- Thrust bearing : Ball or roller bearing (oil lubrication)
- Impeller : Open type having blade of 3dimensions
- 설치방법 : 1상식 및 2상식
- 회전방법 : 구동기에서 보았을 때 우회전
- 토출 플랜지 : KS 10kg/cm<sup>2</sup> FF
- 설치장소 : 옥내 및 옥외
- 슬리브 베어링 : 고무베어링 (물 윤활), 청동 (그리스 윤활)
- 스톨러스트 베어링 : 볼 및 롤러 베어링 (오일 윤활)
- 임펠러 : 3차원 깃을 가진 OPEN TYPE

### Standard Specification / 표준사양

- Total head : 2 - 6m
  - Capacity : 20 - 1000m<sup>3</sup>/min
  - Temp : 0 - 40°C
  - Bore : 500mm - 2500mm
- \*Larger sizes are also available for customized specifications.

- 전양정 : 2 - 6m
  - 유량 : 20 - 1000m<sup>3</sup>/min
  - 온도 : 0 - 40°C
  - 구경 : 500mm - 2500mm
- \*상기 사양범위를 초과하는 대형 펌프도 제작합니다.



Sectional Drawing / 조립 단면도

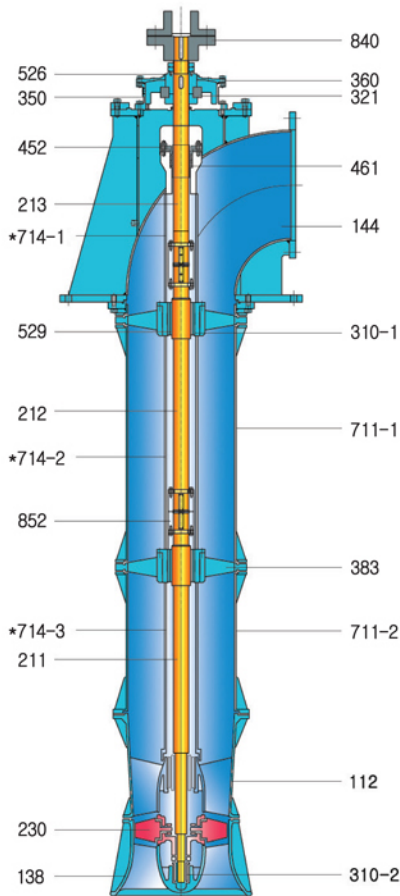

Part No. (품번)	Part Name (부품명)	Standard Material (표준재질) ASTM / KS			Q'ty (수량)
		CLASS1	CLASS2	CLASS3	
112	Guide Casing	A48-CL30 / GC200		A743-CF8 / SSC13	1
138	Suction Bell				1
144	Discharge Elbow				1
211	Shaft(Lower)	A108-1045 / SM45C	A276-304 / STS304		1
212	Shaft(Middle)				1
213	Shaft(Upper)				1
230	Impeller	A48-CL30 / GC200	A743-CF8 / SSC13	A743-CF8 / SSC13	1
310-1	Sleeve Bearing	RUBBER+A743-CF8 / RUBBER+SSC13			2
310-2	Sleeve Bearing				1
321	Ball Bearing	A295-521100 / STB2			1
350	Bearing Housing	A48-CL30 / GC200			1
360	Bearing Cover	A48-CL30 / GC200			1
383	Bearing Spider	A48-CL30 / GC200	A743-CF8 / SSC13		2
452	Packing Gland	A48-CL30 / GC200	A743-CF8 / SSC13		1
461	Packing	NON-METALLIC			5
526	Centering Sleeve	A108-1045 / SM45C			1
529	Bearing Sleeve	A276-304 / ST304			3
711-1	Column Pipe(Upper)	A53 Type F / SPP		A312-TP304 / STS304TP	1
711-2	Column Pipe(Lower)			1	
*714-1	Shaft Pro.Pipe(Upper)	A312-TP304 / STS304TP			1
*714-2	Shaft Pro.Pipe(Middle)				1
*714-3	Shaft Pro.Pipe(Lower)				1
840	Coupling	A48-CL30 / GC200			1SET
852	Screwed Coupling	A276-304 / STS304			1SET

Legends (범례)

\* : Option Parts (선택부품)

CLASS1 : Intake(취수), Industrial water(공업용수), Agricultural water(농업용수), Drainage(배수)

CLASS2 : Urbans(도시), Drainage at mills(고장배수), Filthy water(오수)

CLASS3 : Seawater(해수)

\* Shaft protec.pipe is standard for only sewage system (influent & effluent)



Outline Drawing / 외형 치수도

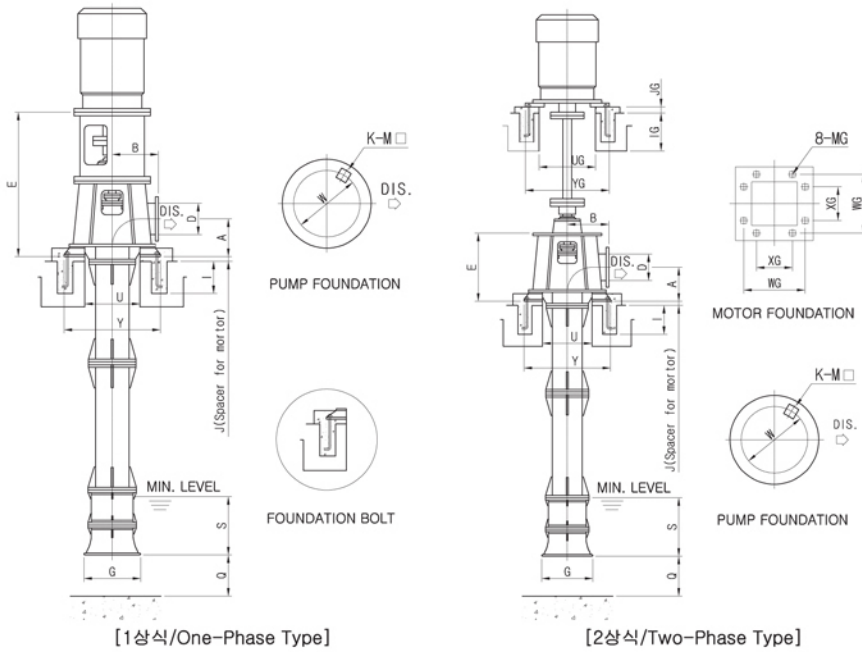

[1상식/One-Phase Type]

[2상식/Two-Phase Type]

Model (형식)	Pump							Pump Base and Foundation							Motor Foundation						
	D	A	B	E	G	Q(min)	S(min)	Y	U	W	K-M	I	J	YG	UG	XG	WG	MG	IG	JG	
GVA 500	500	570	700	950	750	550	1100	1480	950	1400	6-190	630	40	1870	1500	950	1800	130	315	40	
GVA 600	600	620	700	1220	850	650	1250	1700	1100	1600	8-220	800	40	2170	1700	1000	2100	150	400	40	
GVA 700	700	730	850	1250	1000	750	1500	1800	1200	1700	8-220	800	50	2370	1900	1200	2300	150	400	50	
GVA 800	800	815	950	1425	1100	850	1650	1900	1300	1800	8-220	800	50	2600	2000	1400	2500	190	630	50	
GVA 900	900	880	1050	1450	1250	950	1850	2100	1500	2000	8-260	1000	50	2800	2200	1600	2700	190	630	50	
GVA 1000	1000	930	1150	1550	1450	1100	2150	2350	1700	2250	8-260	1000	50	3000	2400	1800	2900	190	630	50	
GVA 1200	1200	900	1150	1600	1650	1300	2650	2400	1800	2350	12-220	1000	50	3000	2500	600	1800	200	630	50	
GVA 1350	1350	1130	1100	1895	1750	1450	3050	2500	2100	2350	16-220	1000	50	3100	2600	600	2000	200	900	50	
GVA 1500	1500	1550	1350	2400	1800	1600	3650	2700	2100	2500	16-260	1000	50	3300	2700	700	2100	220	900	50	
GVA 1650	1650	2350	1500	2600	2300	1650	4125	3500	2900	3400	16-260	1000	50	3500	2900	800	2300	260	900	50	
GVA 1800	1800	2700	1700	2800	2500	1800	4500	3700	3100	3600	16-260	1000	50	3700	3100	900	2500	260	900	50	
GVA 2000	2000	3000	1800	3000	2800	2000	5000	3950	3300	3850	16-260	1000	50	3400	3300	1000	2700	260	1200	50	
GVA 2200	2200	3300	1900	3200	3100	2200	5500	4100	3500	4000	16-260	1000	50	4100	3500	1100	2900	260	1200	50	
GVA 2500	2500	3700	2100	3400	3500	2500	6250	4200	3700	4200	16-260	1000	50	4300	3700	1200	3100	260	1200	50	

\* Note : All dimensions (millimeters) / Contact us for specific dimensions.

Selection Chart / 선정도

50Hz

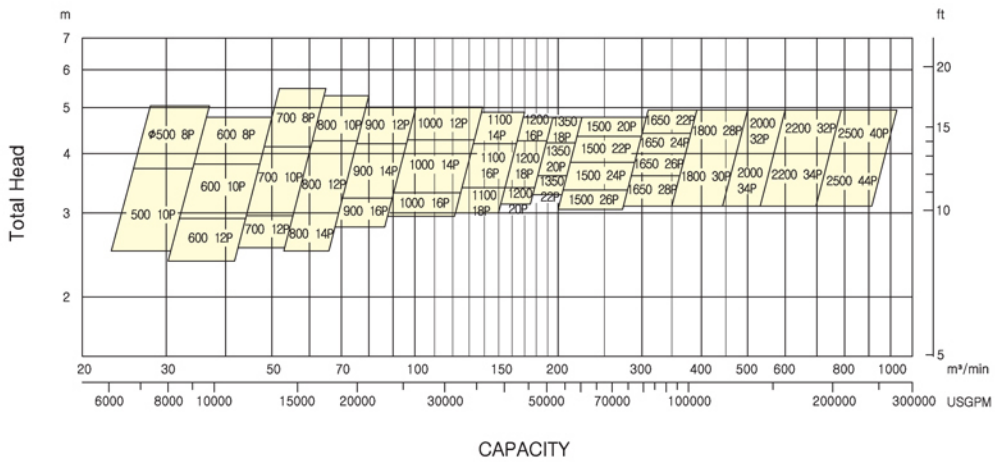

60Hz

