

Pulsing System 탈진설비

DIAPHRAGM VALVE

AIR HEADER

COIL COVER

CONNECTOR

ENCLOSURES

The products of new idea and customer's satisfaction

Air Header



고객감동의 최고품질을 추구하는 조일기업은 30여년간의 축적된 KNOW-HOW와 기술력으로 완벽한 AIR HEADER 일체형 DIAPHRAGM VALVE를 개발하여 고객만족에 최선을 다 하고 있습니다.

JOIL enterprise pursuing the best quality moving the customers, accumulated know-how and technology for 30 years, so it developed a perfect AIR HEADER all-in-one type valve to do its best for customer satisfaction.

VALVE 일체형 AIR HEADER의 특징

- > 우수한 내구성 : 알루미늄 재질의 미려한 외관 및 내식성 (JIAC Type)
- > 밸브효율 증대 : HEADER와 BLOW-TUBE의 배관단축 및 직선화로 효율증대
- > 가공품으로 용접, 배관 시의 치수 변형이 없어 조립 공차문제의 해결
- > 별도의 배관공사없이 설치, 조립



- > Corrosion resistance with aluminum material and elegant appearance with powder coating.
- > Increasing efficiency with plumbing shortening & straightening of header and blow-tube.
- > Without dimensional deformation at plumbing, so assembly tolerances issue is solved.
- > Installation and assembly without separate plumbing work.

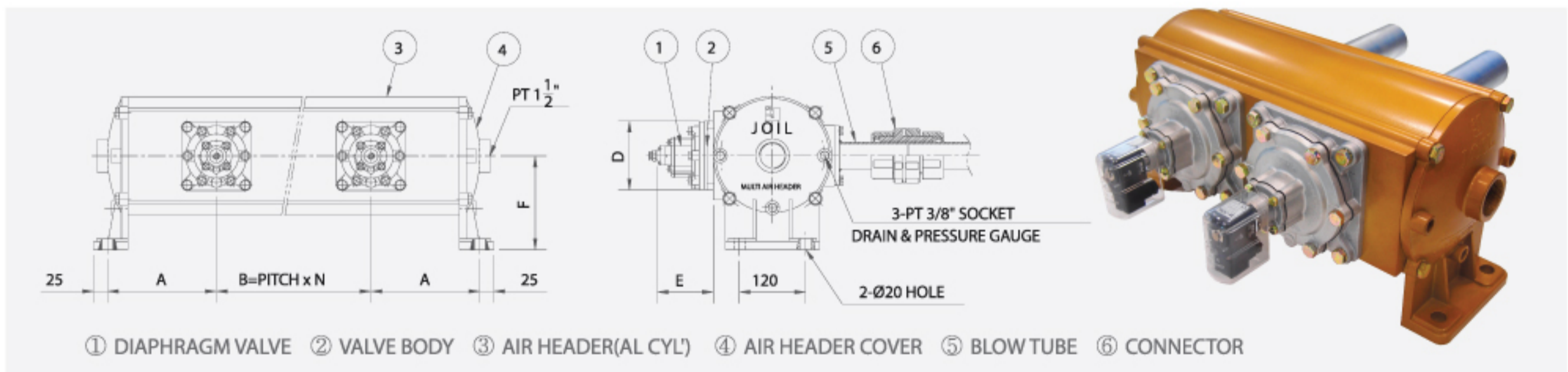

DIMENSIONS (mm)

UNIT(mm)

MODEL	A	C	D	E	F	PITCH	적용가능 밸브숫자
JIAC 40A(S)	185	214	125	90	170	200	5 ~ 15
JIAC 40A(D)	185	214	125	106	170	200	5 ~ 15
JIAC 50A	185	214	160	130	170	260	5 ~ 11

□ Pipe 규격은 당사 표준사양임. Pitch는 주문사양에 따라 변경 가능함. □ Pipe standards is our company's standard specifications. Pitch is possible to change by orders.

SPECIFICATION

UNIT(mm)

MODEL	HEADER SIZE	BLOW TUBE SIZE	PITCH(min)	INLET TUBE SIZE	Cv	VENT HOSE SIZE	OPER-PRESS(max)
JIAC 40A(S)	200A	40A	170	1½"	67.2	RC8	8kgf/cm2
JIAC 40A(D)		40A	170	1½"	70.0	RC8	
JIAC 50A		50A	170	1½"	98.0	RC8	

MULTI TIMER

차압식 TIMER

원격제어형 TIMER

MANO METER

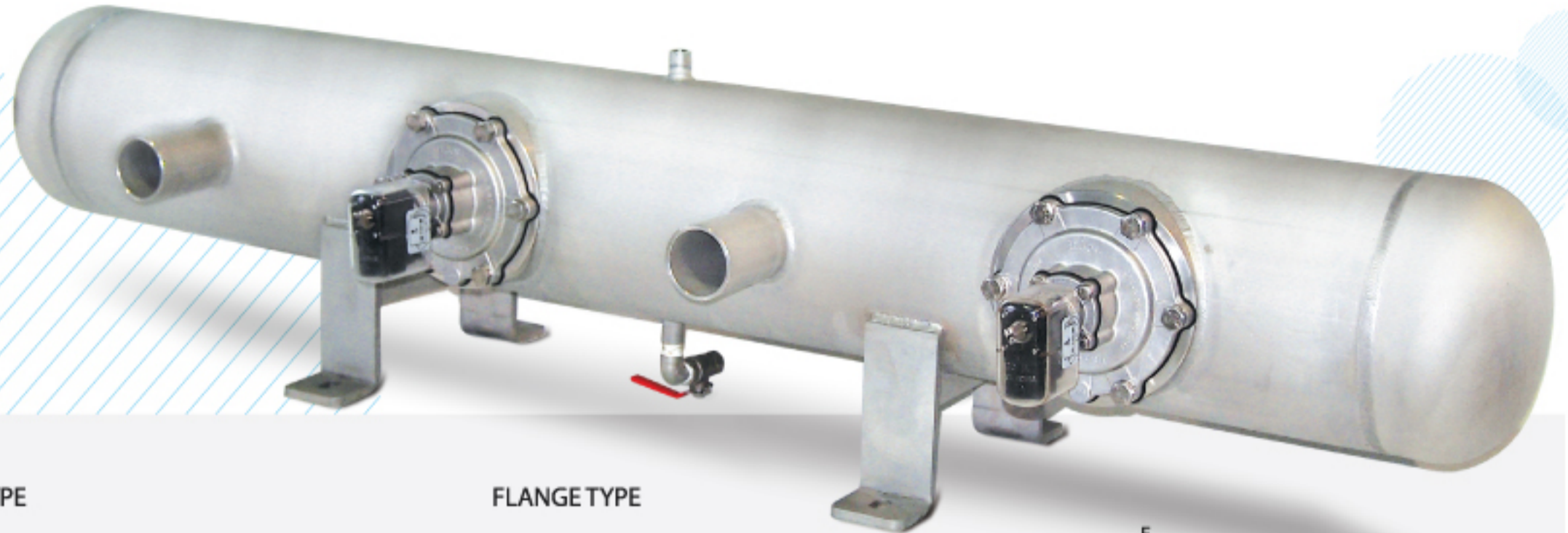

SHELL TYPE

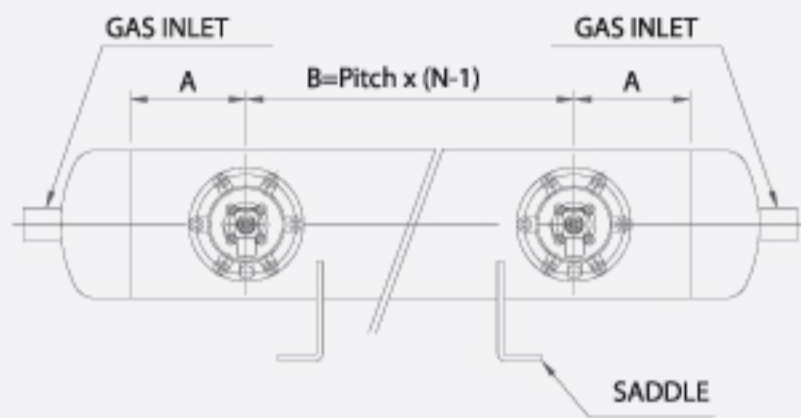

FLANGE TYPE

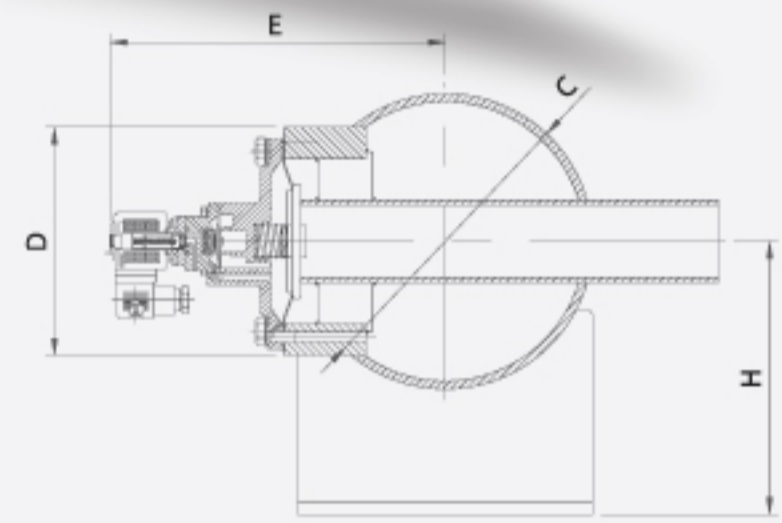
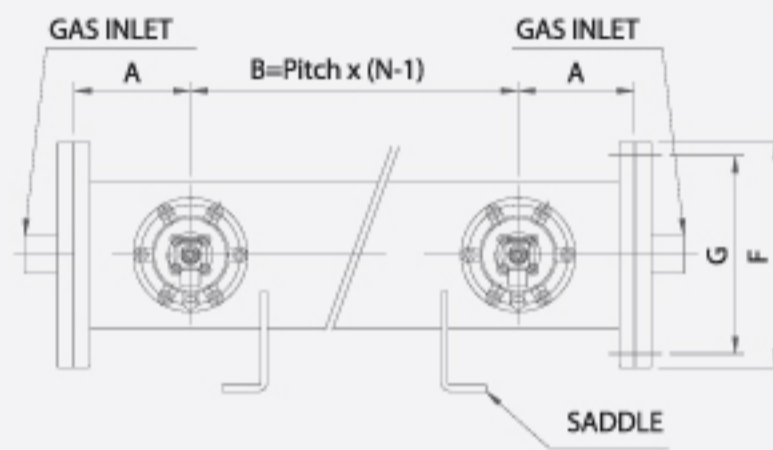

▣ DIMENSIONS (mm)

UNIT(mm)

MODEL	A	C	D	E	F	G	H	PITCH	적용가능 밸브숫자
JAR 20A	168	150	84	97	250	200	75	150	2 ~
JAR 25A	168	150	101	103	250	200	75	150	2 ~
JAR 32A	168	200	125	115	300	250	100	170	5 ~
JAR 40A(S)	168	200	125	115	300	250	100	200	5 ~
JAR 40A(D)	168	200	125	147	300	250	100	200	5 ~
JAR 50A	168	250	167	156	350	300	125	260	5 ~
JAR 65A	168	250	195	160	350	300	125	260	5 ~
JAR 80A	168	300	250	180	400	350	150	300	5 ~
JAR 100A	168	300	250	180	400	350	150	300	5 ~

- ▣ Pipe규격 및 Pitch는 당사 표준사양이며 주문에 따라 변경 가능함.
- ▣ 80A, 100A는 Header-Pipe 조립부의 형상이 다르므로 조립도면을 확인 할것.
- ▣ Pipe standards & pitch is our company's standard specifications and it is possible to change by orders.
- ▣ 80A, 100A has different shape of header-pipe assembly department, so please check assembly drawings.

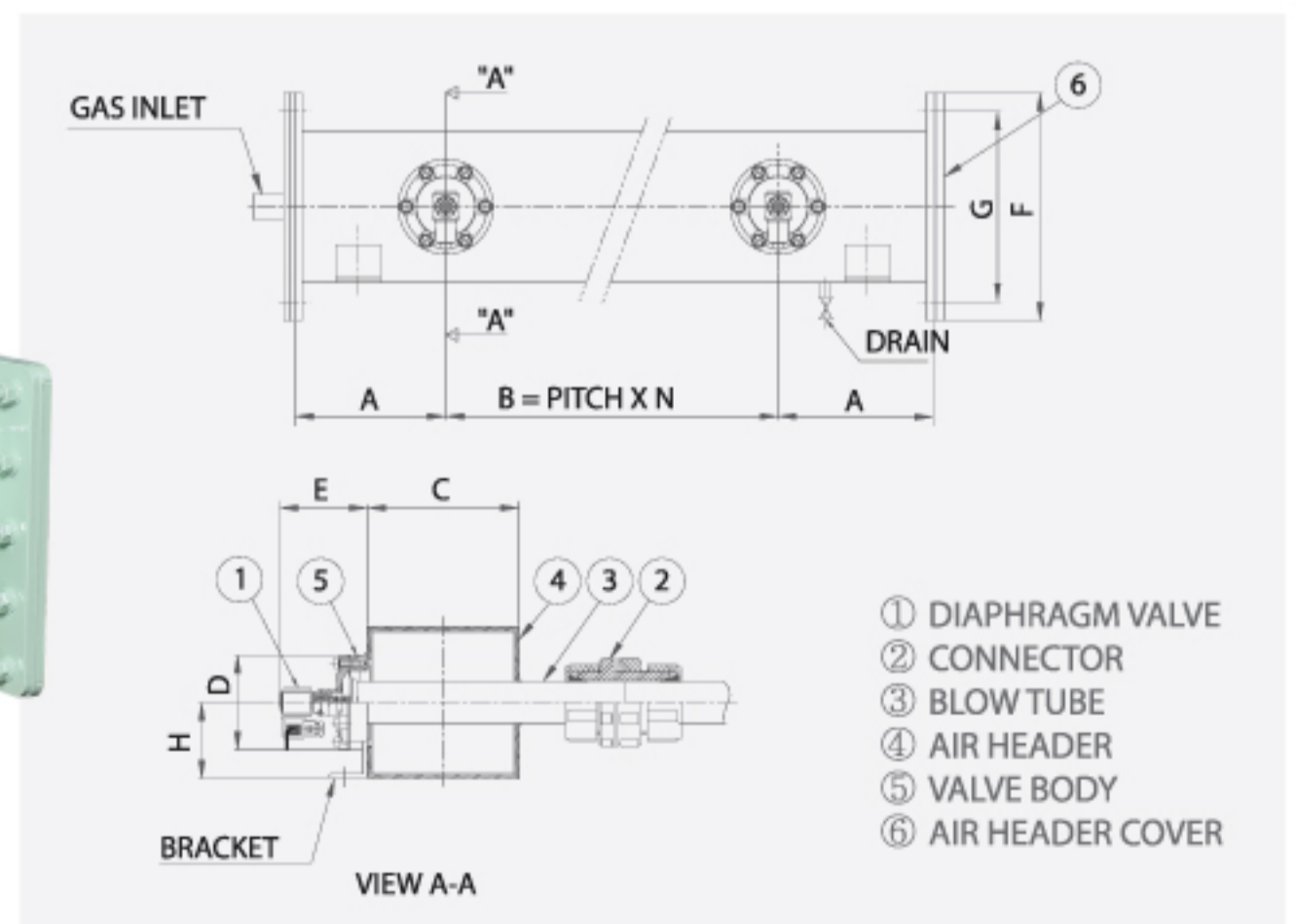
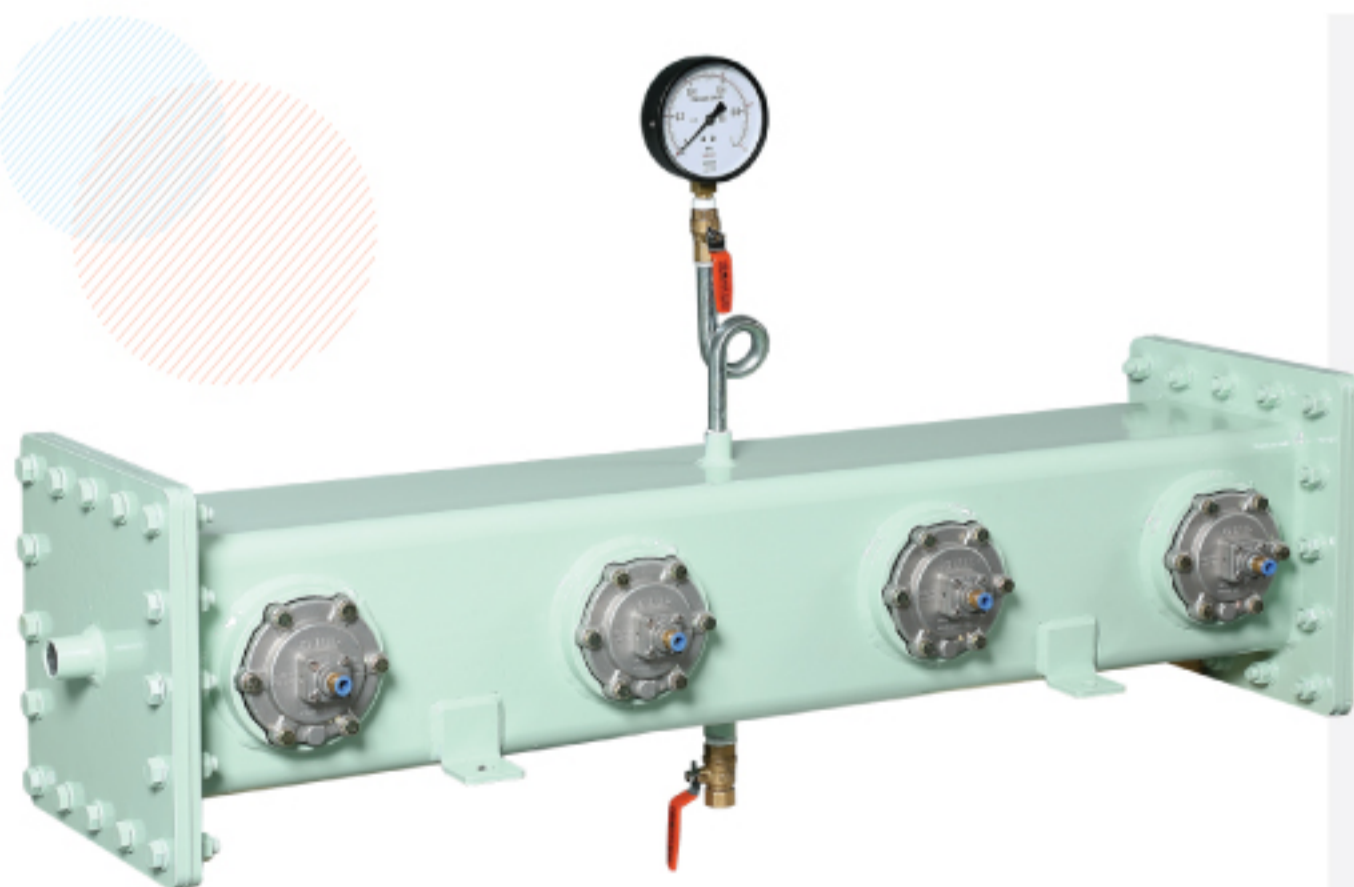

▣ DIMENSIONS (mm)

UNIT(mm)

MODEL	A	C	D	E	F	G	H	PITCH	적용가능 밸브숫자
JIAS 20A	168	150	84	97	250	200	75	150	2 ~
JIAS 25A	168	150	101	103	250	200	75	150	2 ~

- ▣ 내경 SIZE 150mm 이하의 제품은 산업안전보건공단 압력용기 미해당. (150mm 이상의 크기는 협의)