

CS76 Pressure Switch CD76 Explosion-Protected Construction Pressure Switch

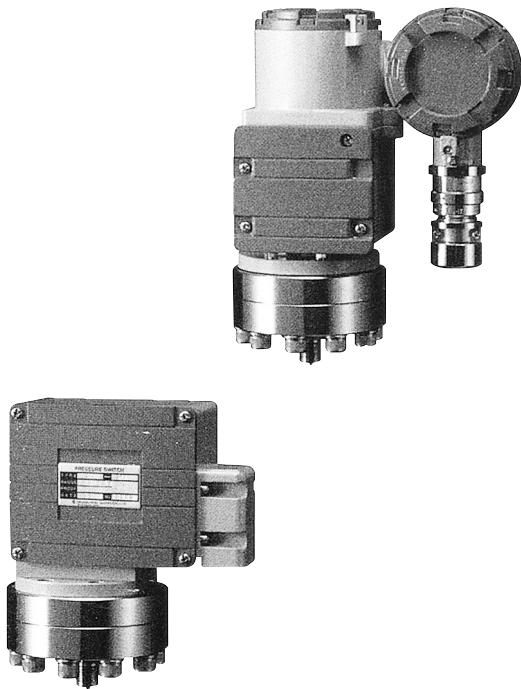

OUTLINE

This device is suitable for controlling pneumatic pressure, hydraulic pressure and various other fluid pressures such as liquid level control and flow control. This is a low setting, high-pressure withstanding type and reliable switch.

FEATURES

- With the application of a Belleville spring, this pressure switch demonstrates excellent vibration resistance and durability. (Double Snap Action Mechanism)
- This pressure switch is appropriate for the application of high pressure resistance and low pressure setting.
- Minute adjustment can be easily performed even at job side.
- Acid-proof coating prevents rusting from salt damage.

SPECIFICATION

Model :

- CS76 General process use
CD76 Explosion-protected construction (Exd II B+H₂ T4)

Fluid :

Gas or liquid

Operating condition :

CS76

Under the normal condition, where there is no inflammable gas or liquid which cause the ignition or explosion.

CD76

Hazardous area The details refer to explanation column of explosion-protected construction.

Mounting :

Panel mounting, 2B pipe mounting (CD76 only)

Connection :

G3/8B (PF), G1/2B (PF), Rc 1/4 (PT female),
Rc 1/2 (PT female), 1/4NPT female
※For other connections, please contact us.

Wetted parts material :

Diaphragm 316 st.st. (At the time of 0.08~0.8MPa
range 631 st.st.)

Flange · socket 316st.st.

Pressure range :

0.01~0.1→0.08~0.8MPa
(0.1~1→0.8~8kgf/cm²)

Max. operating pressure :

10~35MPa (100~350kgf/cm²)
(Depending on range)

Operating temperature :

CS76 -20~60°C (Fluid : -20~80°C)
CD76 -5~40°C (Fluid : -20~80°C)

Accuracy :

1%max.P.

Dead band :

Adjustable 0.01~0.02→0.08~0.16MPa
(0.1~0.2→0.8~1.6kgf/cm²) (Adjustable range)
(Depending on range)

Switch :

Micro switch

Number of contact :

One contact or two contact

Setting system :

Internal adjustment type

Outlet for electric wire :

CS76 Conduit type PF3/4 female
CD76 Flame-proof packing type

Construction :

IP65

Case material · finishing :

CS76 Aluminium alloy die casting (ADC12) ·
Blue & Gray Epoxy painted
CD76 Aluminium alloy casting (AC7A) ·
Blue & Gray Epoxy painted

Terminal box : (Option) CS76 only

Although the wire used to have to be removed from the terminal plate and the tester terminal pressed against it when measuring contact resistance, with the provision of a check terminal, simply remove the screws on the terminal plate and insert the terminals of the tester. This ensures stability when measuring and eliminates the trouble of removing the wire from the terminal plate.

Operation lamp : (Option) CS76 only

The on/off state of the pressure switch and the operating state of the microswitch can also be confirmed at a glance.

Weight :

CS76 Approx. 5kgs

SPECIFICATION 2

Electric characteristics :

Switch	Rating			Withstand voltage	Insulation resistance
		Load resistance	Inductive load		
Single setting	125V AC	10 A	6 A	2000V AC Between terminal and case 1 minute	500V DC 100MΩ over Between terminal and case
	250V AC	10 A	4 A		
	125V DC	0.5 A	0.05 A		
	250V DC	0.25 A	0.03 A		
Single setting direct current use	125V AC	10 A	6 A		
	250V AC	3 A	1.5 A		
	125V DC	10 A	6 A		
	250V DC	3 A	1.5 A		
Single setting dual circuits	125V AC	10 A	6 A		
	250V AC	10 A	4 A		
	125V DC	0.5 A	0.05 A		
	250V DC	0.25 A	0.03 A		
• Inductive load : Power factor 0.4 over (AC) Time-constant 7ms or less (DC) ※One contact direct current use : Direct current rating is bigger than standard.					

Pressure range and dead band · Max. operating pressure :

Pressure range MPa (kgf/cm ²)	Dead band MPa (kgf/cm ²) (Adjustable range)	Max. operating pressure MPa (kgf/cm ²)
0.01~0.1 (0.1~1)	0.01~0.02 (0.1~0.2)	10 (100)
0.02~0.2 (0.2~2)	0.02~0.04 (0.2~0.4)	10 (100)
0.04~0.4 (0.4~4)	0.04~0.08 (0.4~0.8)	30 (300)
0.08~0.8 (0.8~8)	0.08~0.16 (0.8~1.6)	35 (350)

WIRING

CS76

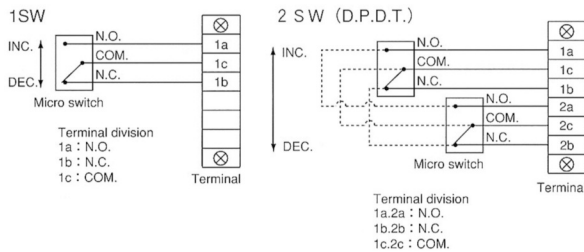

CD76

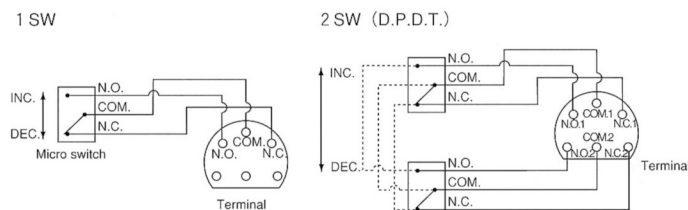

DIMENSIONS

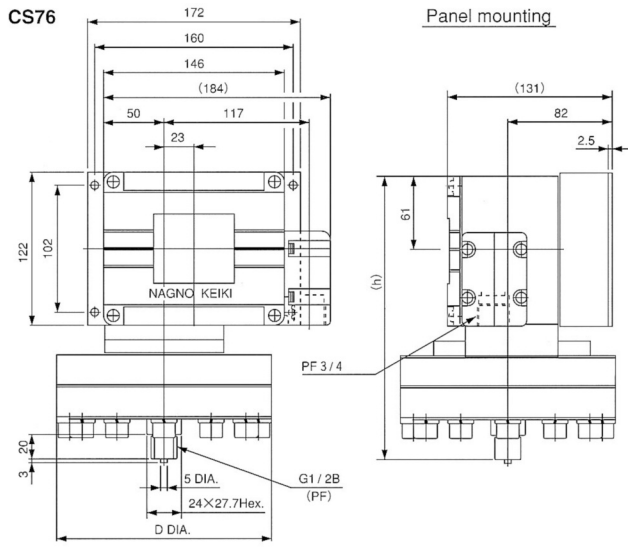

Range	Operating pressure	D	h
0.01~0.1MPa (0.1~1kgf/cm ²)	-0.1~10MPa (-1~100kgf/cm ²)	174	228.5
0.02~0.2MPa (0.2~2kgf/cm ²)	-0.1~10MPa (-1~100kgf/cm ²)	156	226.5
0.04~0.4MPa (0.4~4kgf/cm ²)	-0.1~30MPa (-1~300kgf/cm ²)	128	231.5
0.08~0.8MPa (0.8~8kgf/cm ²)	-0.1~35MPa (-1~350kgf/cm ²)	118	229.5

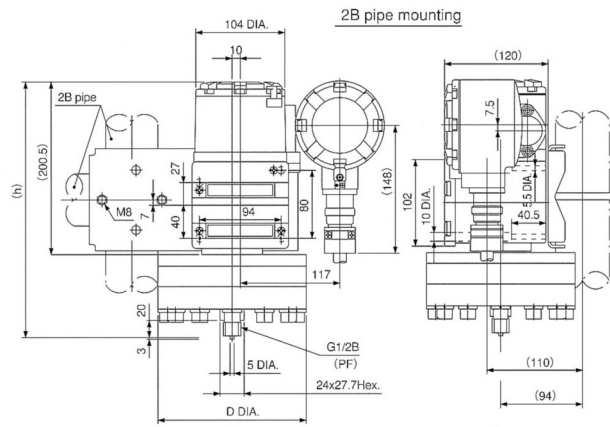
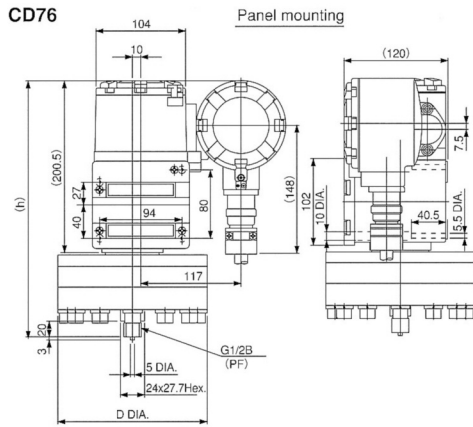
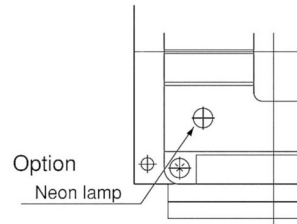

Range	Operating pressure	D	h
0.01~0.1MPa (0.1~1kgf/cm ²)	-0.1~10MPa (-1~100kgf/cm ²)	174	296
0.02~0.2MPa (0.2~2kgf/cm ²)	-0.1~10MPa (-1~100kgf/cm ²)	156	294
0.04~0.4MPa (0.4~4kgf/cm ²)	-0.1~30MPa (-1~300kgf/cm ²)	128	299
0.08~0.8MPa (0.8~8kgf/cm ²)	-0.1~35MPa (-1~350kgf/cm ²)	118	297

OUTLET FOR ELECTRIC WIRE

Conduit connection	Packing inner DIA. (d)	Applicable cable Out DIA.	Protecting tube connection
PF1/2	8 DIA.~12 DIA. Available by 1mm step	7.0 DIA.~12.0 DIA. Available by 0.5mm step	PF1/2
PF3/4	13 DIA.~16 DIA. Available by 1mm step	12.0 DIA.~16.0 DIA. Available by 0.5mm step	PF3/4
PF1	17 DIA.~20 DIA. Available by 1mm step	16.0 DIA.~20.0 DIA. Available by 0.5mm step	PF1

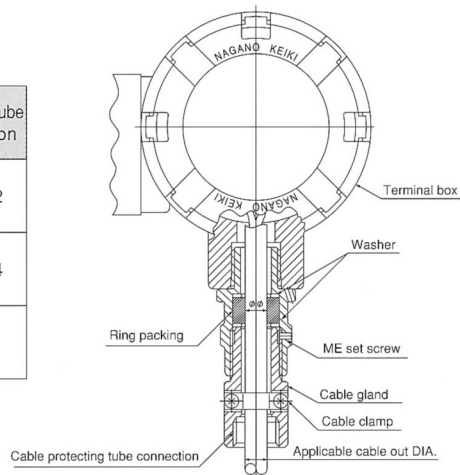

EXPLOSION-PROTECTED CONSTRUCTION

Type approval for explosion-proof : (CD76)

It acquires a technical standard adjusted in international standard IEC by the ministry of Labor notification and the national authorization on the basis of new explosion proof guide.

Type name	Type approval number
CD76	No. C 1 2 3 4 3

Explosion-protected construction :

Explosion protected-construction is a totally enclosed construction such that even if the explosive gas explodes inside the container, the container withstands the force of the explosion and there is no danger of ignition of external explosive gases. As for our pressure switch produced based on this policy, use can have combustible gases or steam of combustibility liquid in pressure measurement at a place with existing fear in a factory, other business office.

Exd II+H₂ T4 :

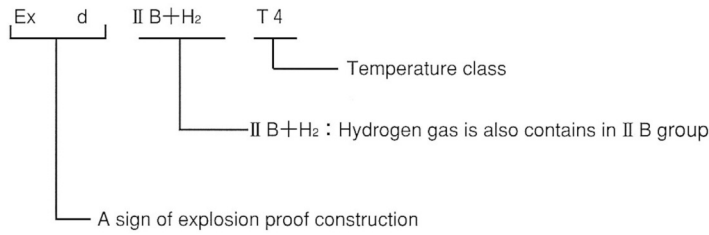

Group classification

A kind of explosion proof electrical instrument and apparatus is classed in group I and group II by a place to be used. CD76 belongs to group II, and comes under machinery using it in a factory except hazardous location of the mine or hazardous location of business office.

Applicable group and classification of gas or steam.

Classification of gas or steam	Applicable group		
A	IIA	IIB	IIC
B	—	IIB	IIC
C	—	—	IIC

Ignition point of gas or steam which T4 can apply.

Ignition point of gas or steam	Applicable temperature class					
Higher than 450°C	T1	T2	T3	T4	T5	T6
Higher than 300°C	—	T2	T3	T4	T5	T6
Higher than 200°C	—	—	T3	T4	T5	T6
Higher than 135°C	—	—	—	T4	T5	T6
Higher than 100°C	—	—	—	—	T5	T6
Higher than 85°C	—	—	—	—	—	T6

Example of applicable gas or steam.

Temperature class / Group	T1	T2	T3	T4	T5	T6
I IA	Acetone Ammonia Carbon monoxide Ethane Acetic acid Ethyl acetate Toluene Propane Benzene Methanol Methane	Ethanol 1-butanol Butane	Hexane	Acetaldehyde		
I IB		Ethylene Ethylenoxide		Ethylmethyl Ether		
I IC	Hydrogen	Acetylene			Carbon bisulfide	Nitric acid ethyl

Type No. constitution

Please specify Type No., each specification and range when ordering.

Note : For this Model, there is no applicable item for the figures X, but please specify X when ordering.

