

# PAPERLESS RECORDER

## Paperless Recorder DYR-B100

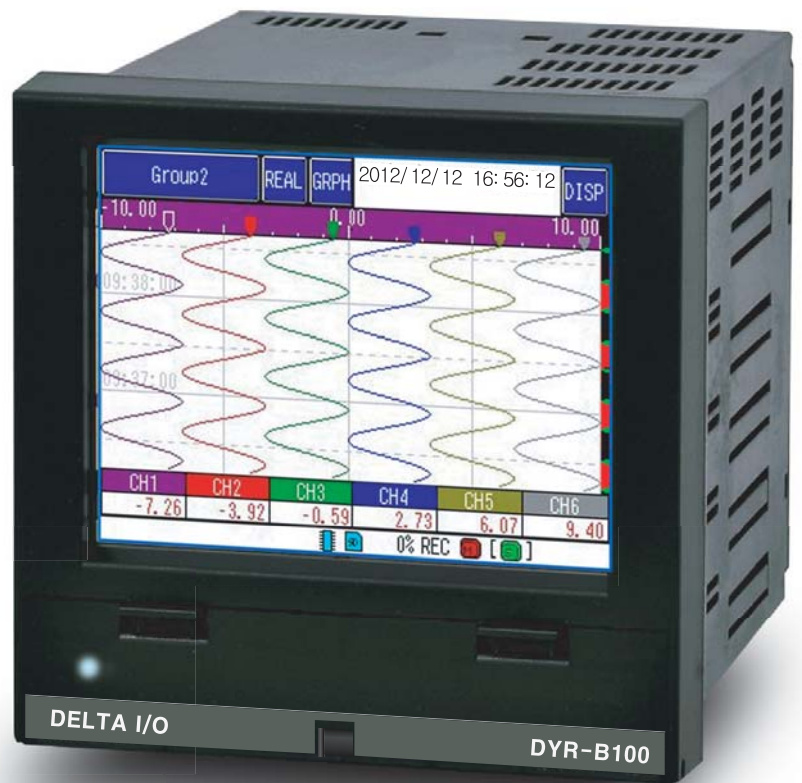

# Easy-to-Use!

Paperless Recorder with Touch Screen

# DYR-B100



## Touch Screen Operation

User friendly interface through a 5.7 inch LCD touch screen. Most of daily operations are achieved on the touch screen.



## Basic Display Screens

Real-time Trend Display (Vertical)

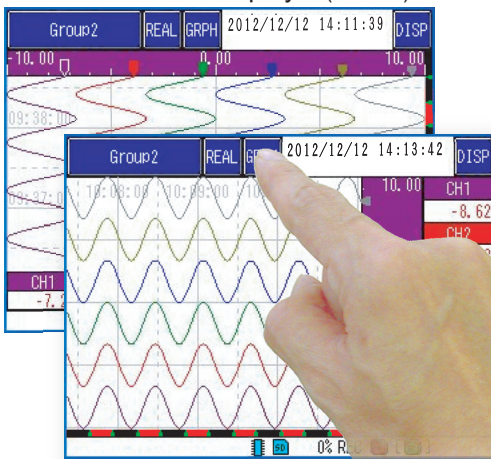

(Horizontal)

Bar Graph Display

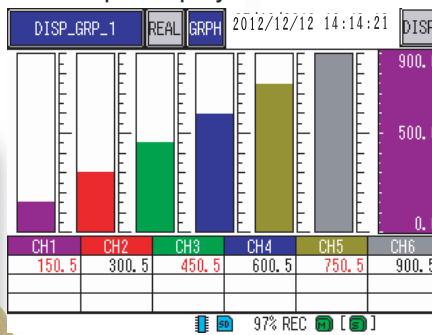

Digital Display

CH1	CH2	CH3	CH4
-9.77 mV	-6.44 mV	-3.11 mV	0.22 mV
CH5	CH6	CH7	CH8
3.55 mV	6.88 mV	10.22 mV	13.55 mV
CH9			
16.88 mV			

- Each press of the GRAPH key on the screen switches the present screen to the next.

Historical Trend Display

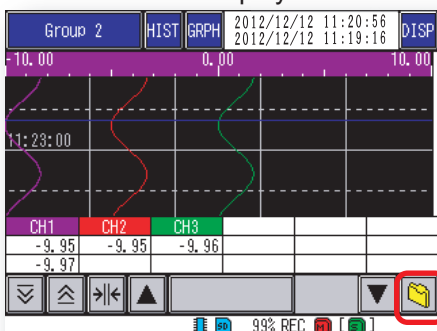

(Saved record files)

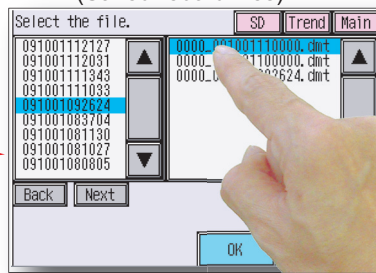

Event History/Communication History Display

Event log	Clear	Update
01/10/2009 12:40:17 CH01 Alarm1 recovery		
01/10/2009 12:39:26 CH01 H Alarm1 occurrence		
01/10/2009 12:39:24 Power ON		
01/10/2009 12:39:20 Power OFF		

- The REAL key on the real time trend screen allows access to the historical data of the currently displayed data and the data from saved file.

- Any event that became active in the currently recorded data as well as a user defined message can be saved in the data file. The LAN communication history can also be logged into the file.

# Quick start of recording at the press of REC button

Recording starts immediately after upon pressing the REC button.

The recorded data can be easily copied to the SD card and viewed with Excel or the supplied software.

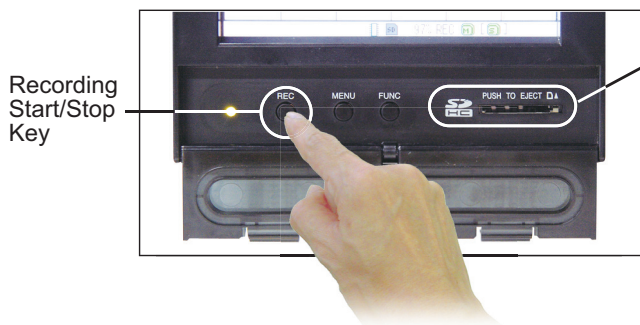

SD Card Slot



32GB SDHC Card

• An SD card is not supplied with the product and must be supplied by the user.

- The recorded data is first stored in the internal Flash memory and then copied into the external SD card when recording is stopped.
- The following table is based on 6 analog inputs (binary format only), without saving max/min values, alarm and messages.

SD Card Capacity	2GB				
	1 hour		1 day		
File saving cycle					
Data recording cycle	1 sec	2 sec	5 sec	10 sec	1 min
Recording capacity	1.0 year	1.4 year	1.8 year	14.0 year	33.7 year

(Recording beyond the service life of the SD card is not warranted.)

- The recorder has an onboard Flash memory (approximately 100MB).
- The data can be saved in CSV format that can be directly edited with Excel or binary format. (whichever is selected \*1).
- Recording cycle is 0.1 second (sub-recording) or adjustable from 1 second to 60 minutes.

\*1 : The storage format is either binary format only or binary format +CSV format.

# Flexible Inputs

Up to 12 analog data can be handled on the main unit.

Use of optional remote inputs expands the inputs up to 36 points.

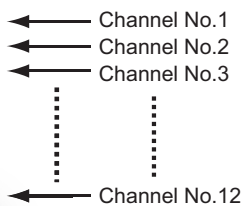

- Thermocouple
- RTD
- DC voltage
- DC current

- Select from 3/6/9/12 input type. [Specify when ordering.]
- Universal input per channel

• When 12 channel input type is specified, no digital inputs/outputs nor relay contact outputs are available.

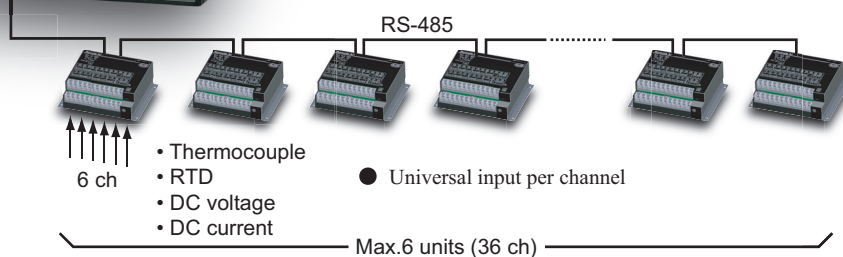

- Thermocouple
- RTD
- DC voltage
- DC current

- Universal input per channel

Max.6 units (36 ch)

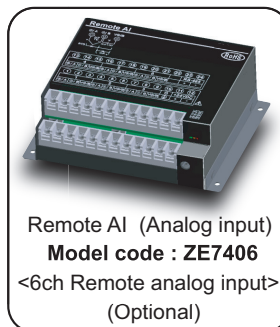

Remote AI (Analog input)  
Model code : ZE7406  
<6ch Remote analog input>  
(Optional)

# Math Function

In addition to arithmetic operations and totalizing of inputs, the math function enables storage of various computed data such as F-value and DI status.

# Lock screen to prevent unintentional operations

Operations via touch screen and front keys can be locked.

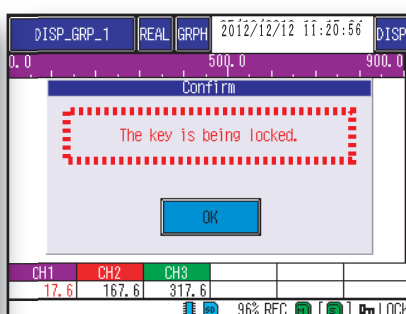
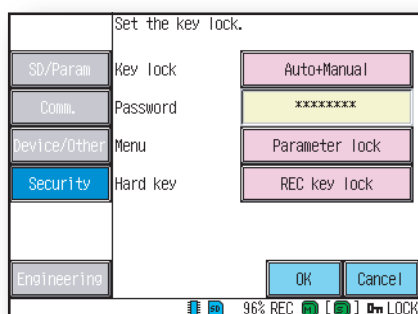

- Security on/off requires password entry.



# Versatile Data Management Function

Comment function allows the user to enter a comment at any time axis. Data management of plural recorders using the supplied software.

## Comment Function

Comment can be entered at any time axis.

● Touching the entered comment switches the screen to the time axis of the selected comment.

Capture Save

The captured screen image can be also saved in bitmap format.

## Real-time Trend Graph

Maximum 8 recorders can be viewed on the same screen via Ethernet.

● Data management Item

- Real-Time Trend Display
- Measured Data (Per recorder)
- Event List (Alarm, etc.)
- List Printing Data (CSV File)

Ethernet (Modbus/TCP) (Standard Function)

Max. 8 units

Software (Data Viewer) • Standard software

- Display: Selectable from trend graph, digital display, and latest value display.
- Recorder can be started/stopped from the Data Viewer (running on PC).

## Parameter Loader Function

The recorder setup data can be uploaded to the recorder and downloaded from the recorder.

Software (Parameter Loader) • Standard software

SETTING1 121213.dps

SETTING2 121225.dps

- ← CH 1 : Thermocouple K
- ← CH 2 : Thermocouple K
- ⋮
- ← CH 1 : DC voltage
- ← CH 2 : DC current
- ⋮

● Setup data can be managed with the SD card and via Ethernet.

# Rear Terminals

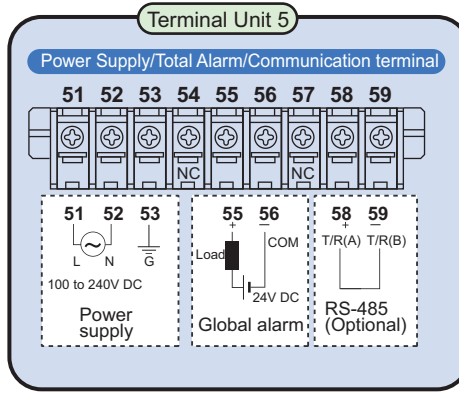
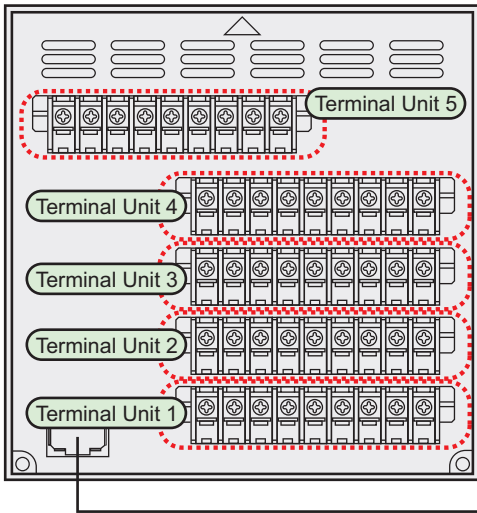

Ethernet Connector

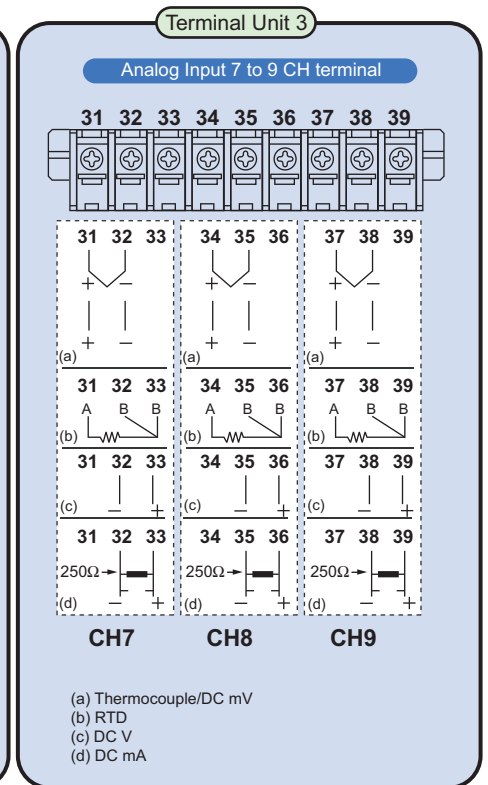
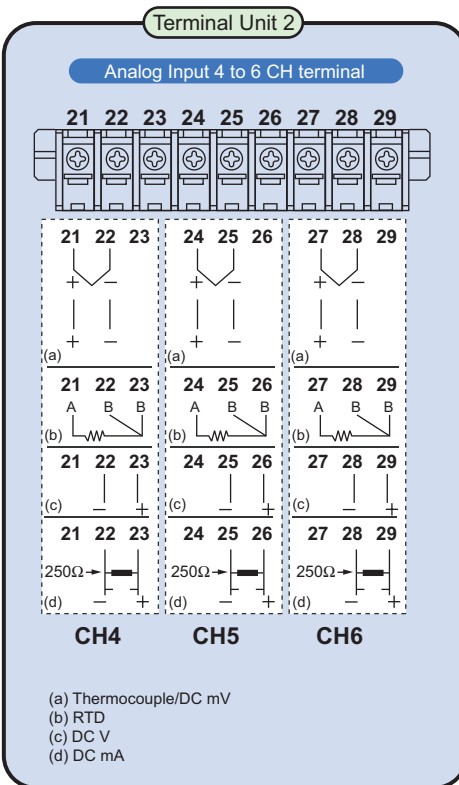
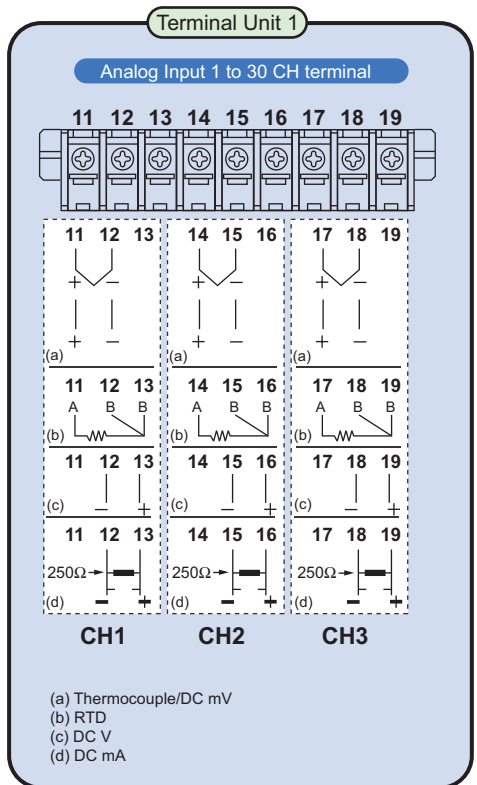
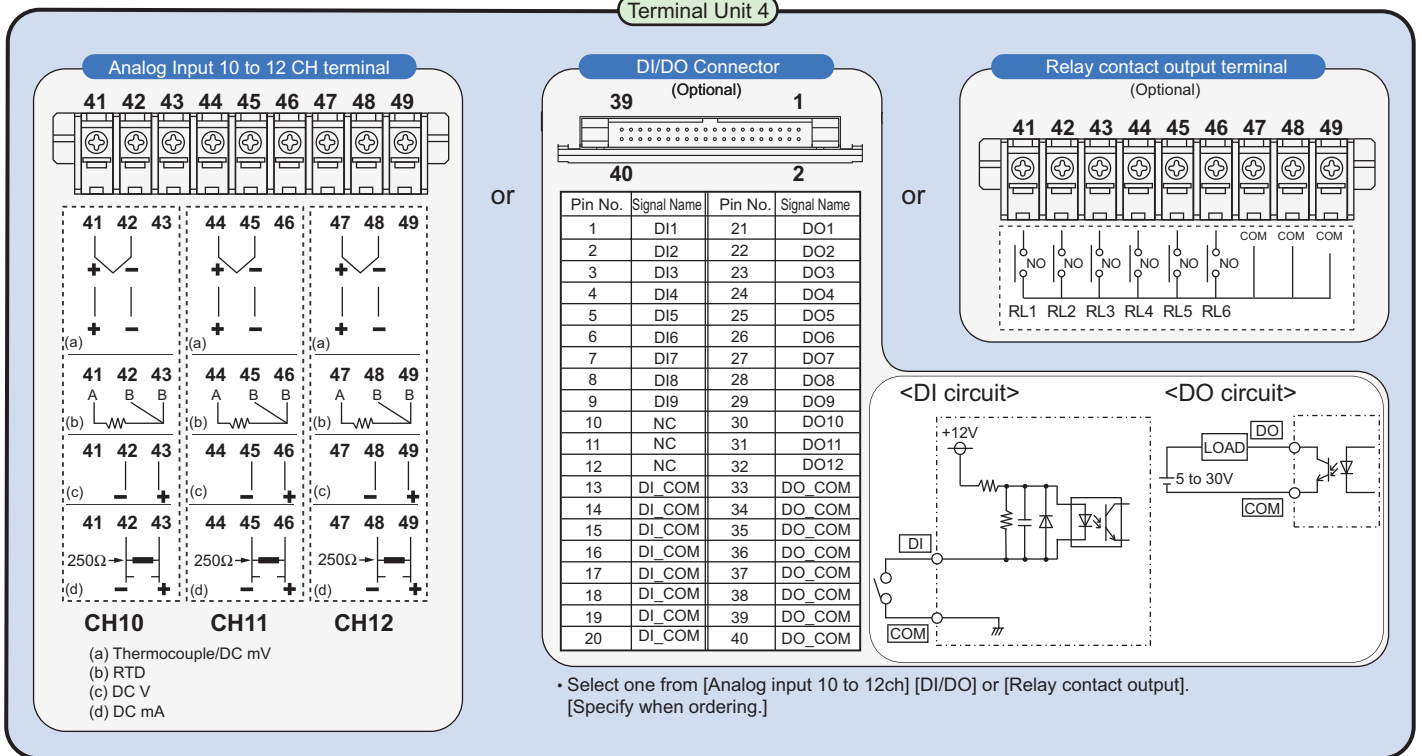

# Specifications

## Input

- Number of inputs** : 3, 6, 9, 12 points  
 • Isolated between each input)
- Measurement interval** : 100m sec
- Input signal** : DC voltage, DC current (Using external shunt resistor), Thermocouple, RTD
- Burnout** : Available on TC and DC mV range, •ON/OFF selectable (per channel)
- Influence of external resistance (Thermocouple)** : Approx. 0.18μV/Ω
- Influence of input lead resistance (RTD)** : Maximum 5Ω per wire
- PV Digital filter** : 0 to 99 sec (OFF when 0 is set.)
- Scaling range** : -32000 to +32000 (DC voltage, DC current input)  
 • Decimal point is programmable
- Unit sign** : Preset units or 20 units (each unit eight characters or less) that can be made.
- Square Root Extraction** : PV ratio + PV bias
- Math function** : Number of math channel : 36 channels  
 Arithmetic, general, multiplication and F value calculation can be computed with each math channel.  
 • The content of the math can be set and be confirmed only with the Parameter Loader Software (Standard supplied)
- F value computation function**  
 : F value of each channel (fatal value of the bacterium by the heating sterilization) is computed from the measurement temperature.  
 The content of the computation can be set and be confirmed only with the Parameter Loader Software (Standard supplied)

### Measurement range/accuracy

Input		Range	Max. Resolution	Measurement Accuracy	
DC Voltage/ DC Current	mV	-10.00 to +10.00	10μV	±(0.1%+1digit)	
		0.00 to +20.00	10μV		
		0.00 to +50.0	10μV		
	V	-0.200 to +0.200	1mV		
		-1.000 to +1.000	1mV		
		-10.00 to +10.00	10mV		
mA	0.000 to +5.000	1mV			
		4.00 to 20.00	0.01mA		
Thermocouple *5	B *1	0.0 to 1820.0	0.1°C	±(0.1%+1digit)	
	R *2	0.0 to 1760.0	0.1°C		
		0.0 to 1200.0	0.1°C		
	S *2	0.0 to 1760.0	0.1°C		
	K	-200.0 to 1370.0	0.1°C	±(0.1%+1digit) • -200.0 to 0.0°C : ±(0.15%+1digit)	
		-200.0 to 600.0	0.1°C		
		-200.0 to 300.0	0.1°C		
	E	-200.0 to 800.0	0.1°C		
		-200.0 to 300.0	0.1°C		
		-200.0 to 150.0	0.1°C		
	J	-200.0 to 1100.0	0.1°C		
		-200.0 to 400.0	0.1°C		
		-200.0 to 200.0	0.1°C		
	T	-200.0 to 400.0	0.1°C		
		-200.0 to 200.0	0.1°C		
	C(W5Re/W26Re)	0.0 to 2320.0	0.1°C		±(0.1%+1digit)
	Au-Fe *3	1.0 to 300.0	0.1K		±(0.2%+1digit)
	N	0.0 to 1300.0	0.1°C		±(0.1%+1digit)
PR40-20 *4	0.0 to 1880.0	0.1°C	±(0.2%+1digit)		
PLII	0.0 to 1390.0	0.1°C	±(0.1%+1digit)		
U	-200.0 to 400.0	0.1°C	±(0.1%+1digit) • -200.0 to 0.0°C : ±(0.15%+1digit)		
L	-200.0 to 900.0	0.1°C			
RTD	Pt100	-200.0 to 650.0	0.1°C	±(0.1%+1digit)	
		-200.0 to 200.0	0.1°C		
	JPt100	-200.0 to 630.0	0.1°C		
		-200.0 to 200.0	0.1°C		

- \*1 0.0 to 400°C : ±4%, 400 to 800°C : ±(0.15%+1digit)
- \*2 0.0 to 200°C : ±(0.15%+1digit)
- \*3 1 to 20K : ±(0.5% + 1 digit), 20 to 50K : ±(0.3%+1digit)
- \*4 0 to 300°C : ±(1.5% + 1 digit), 300 to 800°C : ±(0.8%+1digit)
- \*5 Reference Junction Compensation (Ambient temperature : 23±2°C)  
 R, S, PR40-20, Au-Fe : ±1.0°C, K, E, J, T, C, N, PLII, U, L : ±0.5°C

## Display

- Display** : Touch Panel type 5.7-inch TFT color LCD (320 X 240 dots)
- Display language** : English/Japanese (Selectable by setting )
- Display group** : Number of groups : Main records 6, Sub record 1  
 Number of channels : Max. 12 channels/group
- Display color** : 16 colors
- Display interval** : 1 sec

## Recording

- External memory** : SD memory card (SD/SDHC)
- Internal memory** : Approx. 100MB
- Memory Capacity** : SD : Max. 2GB, SDHC : Max. 32GB
- Main record data** : Trend graph, Event Data, Message data
- Sub record data** : Trend graph  
 • The record condition can be selected from "sync.", "Alarm", "DI".
- Recording cycle** : 1 sec to 60 min (SUB record is possible 100m sec)
- Data saving cycle** : 1 hour to 1 year  
 • Data is first saved to the internal memory and then copied to the SD card at the specified cycle. When the internal memory is full or when recording is stopped, data is saved to the SD card.
- Trend data** : Minimum value, Maximum value, Current value  
 Average value (Selectable)
- Other record data** : Alarm status, Message
- Memory remaining capacity display** : When the SD card is full, recording is stopped or data can overwrite oldest data (whichever is selected)
- Data format** : Binary or Binary + CSV format (Selectable)

## Standard Function

- Alarm** : Number of alarm setting : Max. 4 point per channel  
 Alarm type : High limit, Low limit, Abnormal data  
 Alarm output : 1 point  
 Open collector output, 30V DC, 20mA
- Communication** : Type :Ethernet (10BASE-T)  
 Protocol :Modbus/TCP  
 • Built in HTTP server and FTP server

## Optional Function

- Communication** : Type :RS-485  
 Protocol :Modbus RTU  
 Bit format :  
 Start bit : 1, Data bit :8, Parity bit : Without, Odd or Even  
 Communication speed : 9600 bps  
 Maximum connection : 32 units (Including host)
- Digital input/Digital output**  
 • 12 channel type is not available with Digital input/Digital output.  
 : Number of Digital input : 9 points, Non-voltage input (Same common)  
 Digital input function  
 Recording RUN/STOP, Message setting, Multiplication value RESET  
 LCD backlight ON/OFF  
 : Number of Digital output : 12 points, Open collector output (Same common)  
 30V DC, 20mA/point  
 Digital output function : Alarm output
- Relay contact output**  
 • 12 channel type is not available with Relay contact output.  
 : Number of Relay contact output : 6 points, 250V AC 3A, 30D DC 3A  
 (• 3A/common, Total : Less than 9A)  
 Output function : Alarm output
- Remote AI**  
 A maximum of 6 remote units can be connected via RS-485.

## General Specifications

- Memory backup** : Flash memory.  
 Clock backup : Lithium battery. (Life : Approx 5years at non power supply status)
- Power supply** : 85 to 264V AC (50/60 Hz)
- Power consumption**

Power supply voltage	LCD ON	LCD OFF
100V AC	15VA	12VA
200V AC	25VA	22VA

- Insulation resistance** : Between terminals and ground : 20MΩ or more (at 500V DC)
- Dielectric strength** : 500V AC for one minute between input terminals  
 500V AC for one minute between input terminals and ground  
 2000V AC for one minute between power terminals and ground
- Ambient temperature and humidity** : 0 to 50°C, 20 to 80%RH
- Net Weight** : Approx 1.0kg (3 channels type)
- Waterproof/Dustproof** : IP65 (Front panel)

# Specifications

## External Dimension

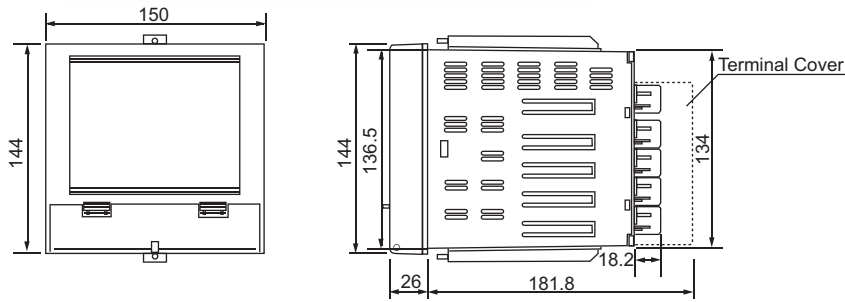

## Panel Cutout

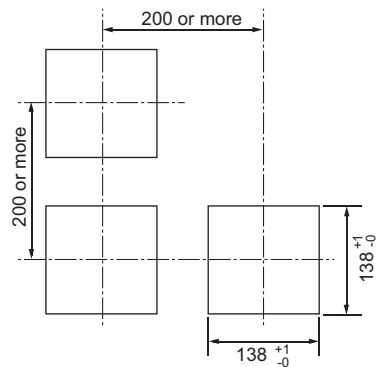

## Remote AI Specifications (Optional)

### External Dimension/Terminals

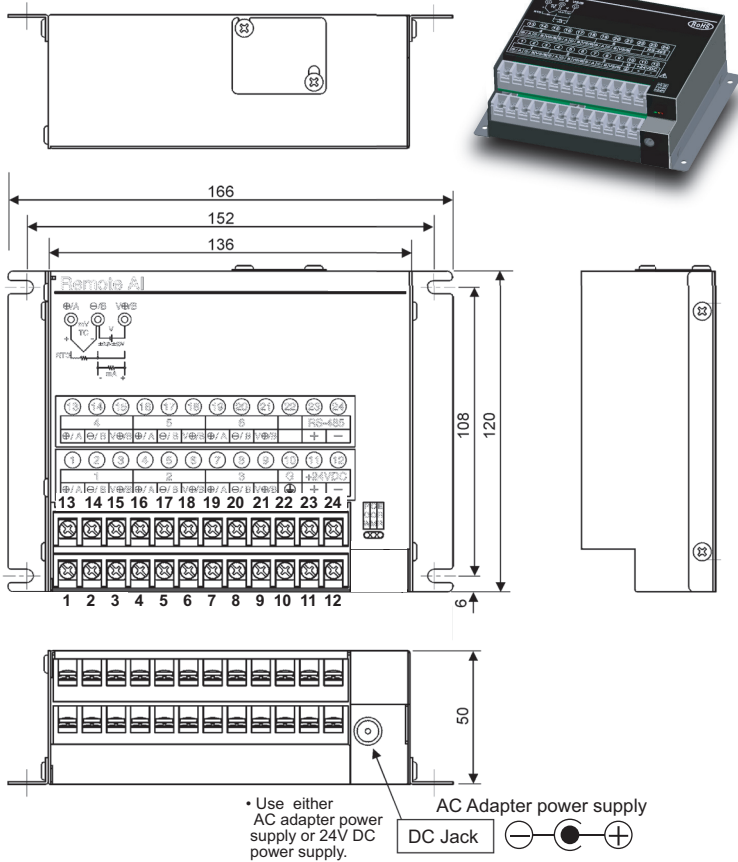

## Specifications

### Analog Input

- Number of inputs : 1, 6, 9, 12 points
- Sampling time : Approx. 0.1 sec/all channel
- Input type and Scaling setting : Set by parameter loader
- Other specifications is same to DYR-B100.

### Communication

- Communication method : RS-485
- Protocol : Modbus RTU
- Bit format : Start bit : 1, Data bit : 8, Parity bit : Without, Odd or Even  
Stop bit : 1
- Communication speed : 9600, 19200, 38400bps  
• Selectable
- Data communication cycle : 1 sec
- Slave address : 1 to 9
- Maximum connection : 6 units to DYR-B100

### General Specifications

- Power supply : 21.6 to 26.4V DC (Rating 24V DC)
- Power consumption : 1.8W
- Insulation resistance : Between terminals and ground : 20MΩ or more (at 500V DC)
- Dielectric strength : 500V AC for one minute between input terminals  
500V AC for one minute between input terminals and ground  
500V AC for one minute between power terminals and ground
- Ambient temperature and humidity : 0 to 50°C, 20 to 80%RH
- Net Weight : Approx 670g
- Mounting method : DIN rail or screw mounting

### Analog input 1 to 3 channel, Power supply

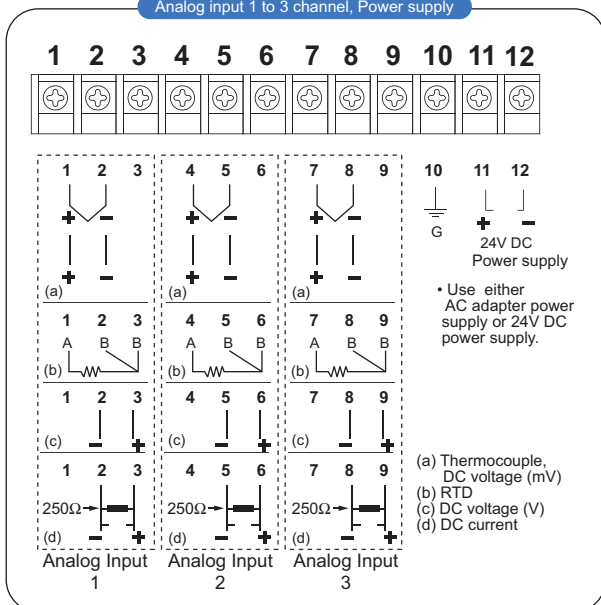

### Analog input 4 to 6 channel, Communication

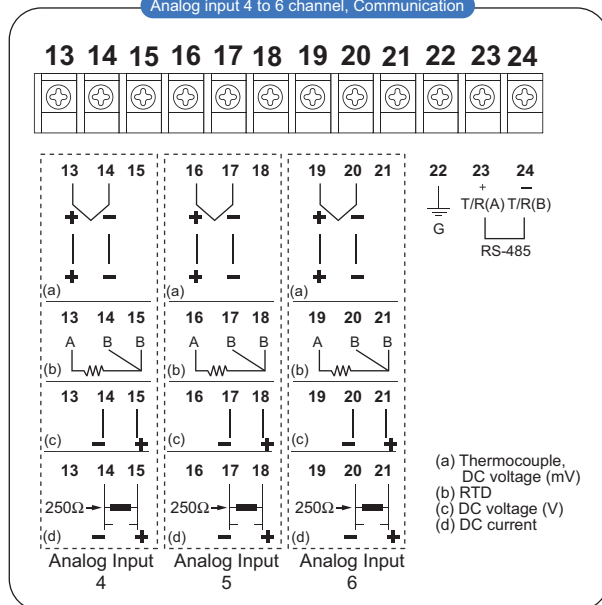



# Model and Suffix Code



## Paperless Recorder

Specifications	Paperless Recorder	DIYR-B	①	②	③
Analog Input	3 points (3 channels)		103		
	6 points (6 channels)		106		
	9 points (9 channels)		109		
	12 points (12 channels) *1		112		
RS-485 Communication	Not supplied			0	
	RS-485			6	
Digital Input/Output function	Not supplied				0
	Digital Input (DI) : 9 points, Digital Output (DO) : 12 points				*1 1
	Relay contact output : 6 points				*1 2

Standard Accessories : Mounting brackets, Packing for waterproof (Panel packing, O-ring)  
CD-ROM (Instruction Manual, Software)

\*1 When 12 channel input type is specified, no digital inputs/outputs nor relay contact outputs are available.

\*2 Ethernet communication is standard function.

### Optional Accessories

#### DI/DO cable

(1m)

Model Code : WMSU0468A01



• Terminal : No treatment

(3m)

Model Code : WMSU0468A02



Shunt resistance for a current input  
Model Code : HMSU3081A11

(250Ω±0.1%)



The terminator for RS-485  
Model Code : WMSU0303A01

200Ω

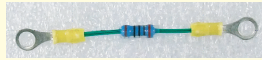

## Remote AI (Analog Input)

Specifications	ZE74	06	A001
Analog Input	6 points		06

Standard Accessories : CD-ROM (Instruction Manual)



### Optional Accessories

#### DIN Rail Mounting Bracket

Model Code : WMSU0678B02

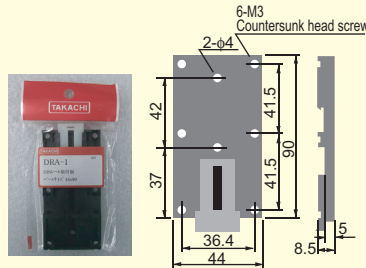

#### AC Adapter

Model Code : WMSU0678B01

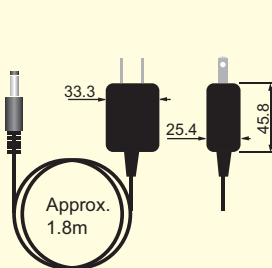

- Before operating this product, read the instruction manual carefully to avoid incorrect operation.
- This product is intended for use with industrial machines, test and measuring equipment. It is not designed for use with medical equipment.
- If it is possible that an accident may occur as a result of the failure of the product or some other abnormality, an appropriate independent protection device must be installed.

## System Configuration

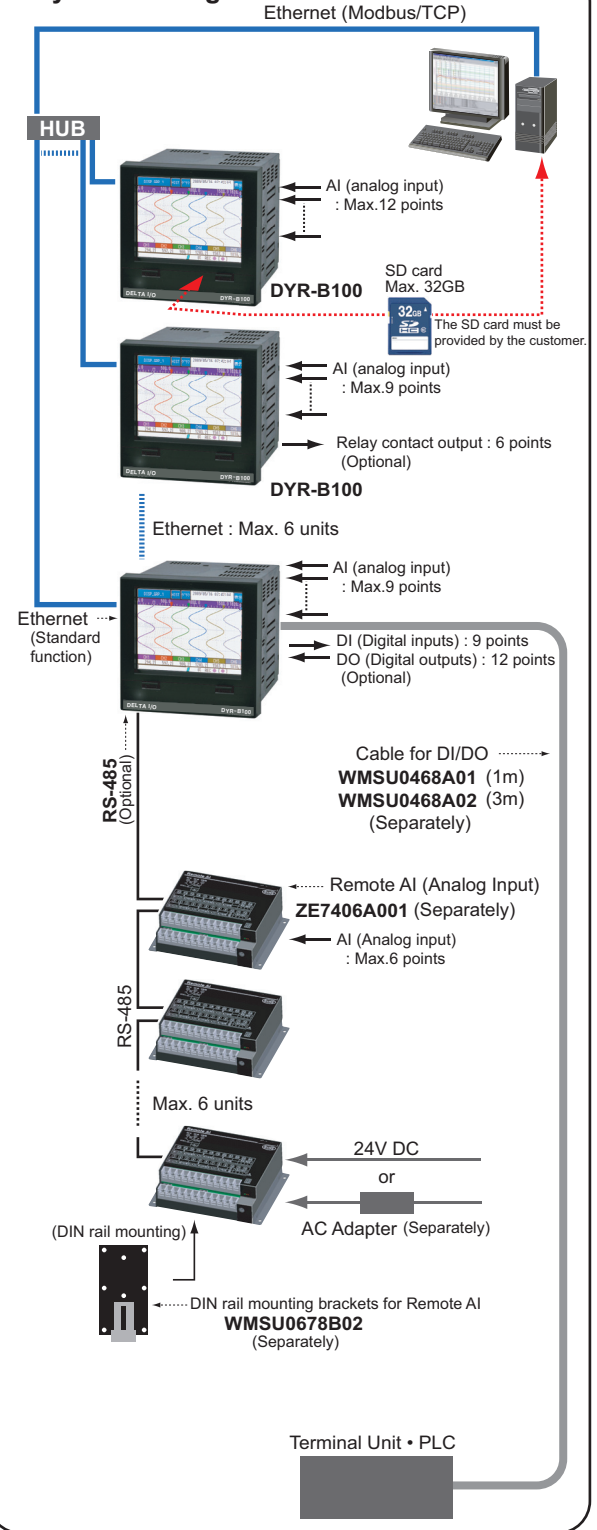

Head office : (443-803)

#55, Sinwon-ro 283beon-gil, Yeongtong-gu, Suwon-city, Korea

http://www.deltaioco.co.kr

TEL 031)245-6001 (Rep)

FAX 031)245-6182

E-mail : deltaio@deltaio.co.kr

**DELTA I/O**