

KJS TYPE

플라스틱 간편조작형

플라스틱 간편조작형으로 안쪽 Cover가 개폐되어 Cable, Hose 분해설치가 쉬우며, 비교적 간단한 공작기계 및 자동화 설비에 적합 합니다.

PLASTIC SIMPLE OPERATION TYPE

THE INSIDE COVER OPENS AND SHUTS SO IT'S EASILY DISASSEMBLED AND CABLE AND HOSE ARE EASILY INSTALLED. IT IS AN OPTIMUM PRODUCT FOR A COMPARATIVELY SIMPLE MACHINE TOOL AND AUTOMATION EQUIPMENT.

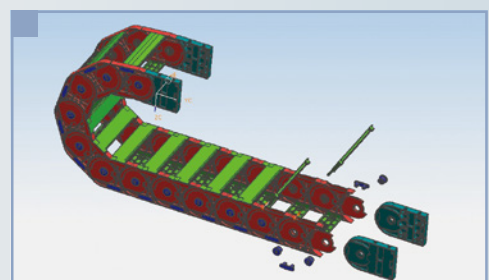

KJS 045 TYPE

⊕ Cablechain / Chain Pitch(P)=45mm

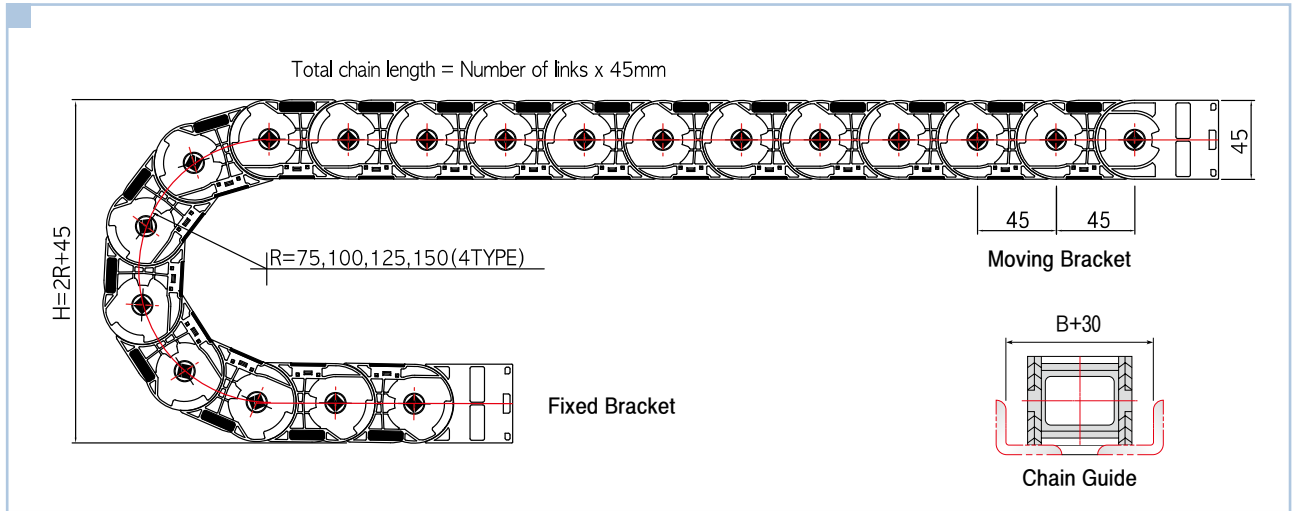

⊕ A-A Cross Section / D.Max

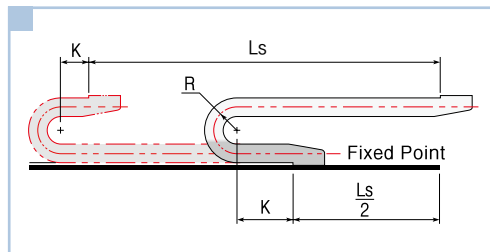
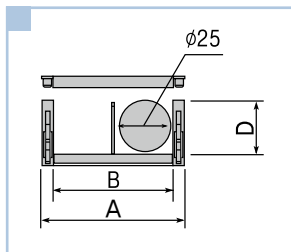

- Chain Length $L = \frac{Ls}{2} + \pi R + 3P(2K)$
- 곡률반경에 따른 H값

R	75	100	125	150
H	195	245	295	345

단위 mm

SERIES	KJS 045-B50	KJS 045-B75	KJS 045-B100	KJS 045-B125
R	75, 100, 125, 150			
A	68	93	118	143
B	50	75	100	125
D	36			

※ Manufacturing Tolerance of ± 10%

⊕ End Bracket (택 1)

Plastic Type

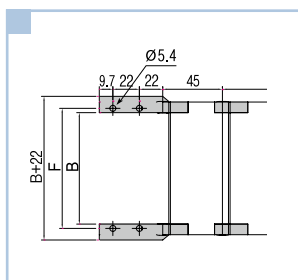

Steel Type

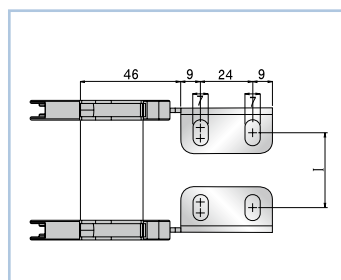

단위 mm

SERIES WITH RODS	F(B+8.5)	I(B-10)
KJS 045-B50	58.5	40
KJS 045-B75	83.5	65
KJS 045-B100	108.5	90
KJS 045-B125	133.5	115

⊕ Order Example [주문예]

KJS 045-B50 / Type ➤ R75 / Radius ➤ 50L/K / Length ➤ 3Sets(P/S) / Q'ty

⊕ Cablechain / Chain Pitch(P)=65mm

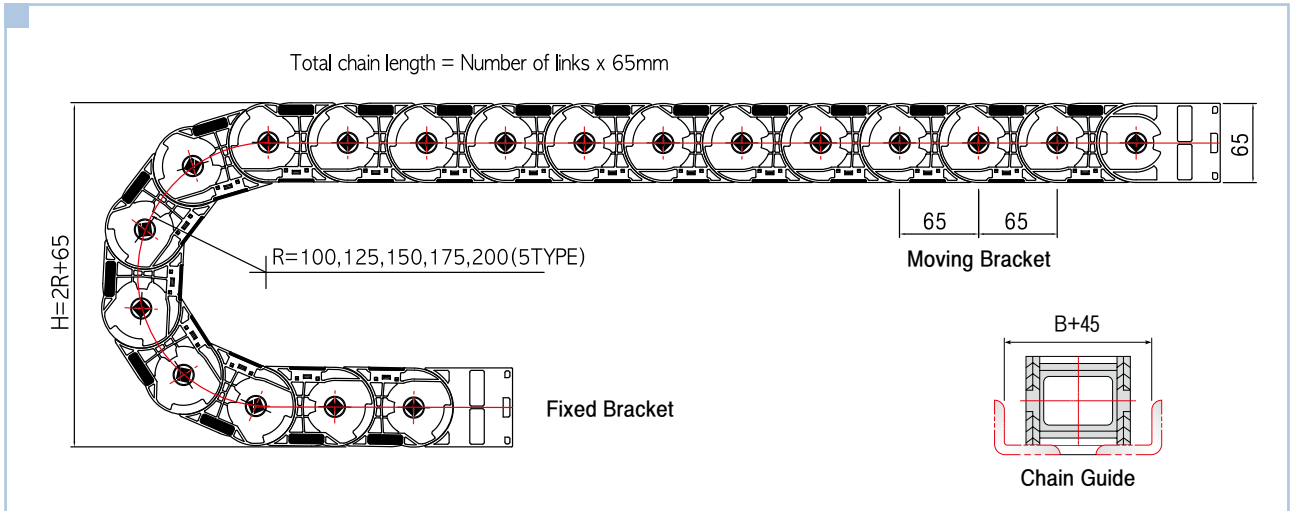

⊕ A-A Cross Section / D.Max

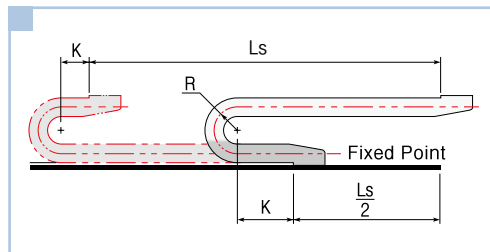
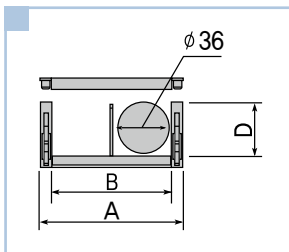

- Chain Length $L = \frac{Ls}{2} + \pi R + 3P(2K)$
- 곡률반경에 따른 H값

R	100	125	150	175	200
H	265	315	365	415	465

단위 mm

SERIES	KJS 065-B75	KJS 065-B100	KJS 065-B125	KJS 065-B150
R	100, 125, 150, 175, 200			
A	102	127	152	177
B	75	100	125	150
D	52			

※ Manufacturing Tolerance of $\pm 10\%$

⊕ End Bracket (택 1)

Plastic Type

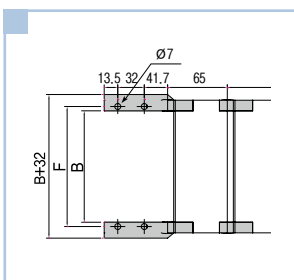

Steel Type

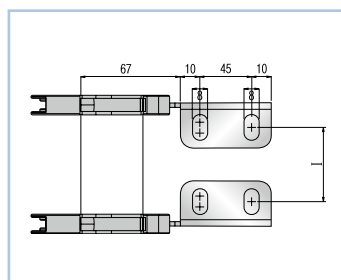

단위 mm

SERIES WITH RODS	F(B+12)	I(B-15)
KJS 065-B75	87	60
KJS 065-B100	112	85
KJS 065-B125	137	110
KJS 065-B150	162	135

⊕ Order Example [주문예]

KJS 065-B100 / Type ➤ R150 / Radius ➤ 50L/K / Length ➤ 5Sets / Q'ty

KJS 090 TYPE

KUKJE CABLECHAIN

KJS TYPE

⊕ Cablechain / Chain Pitch(P)=90mm

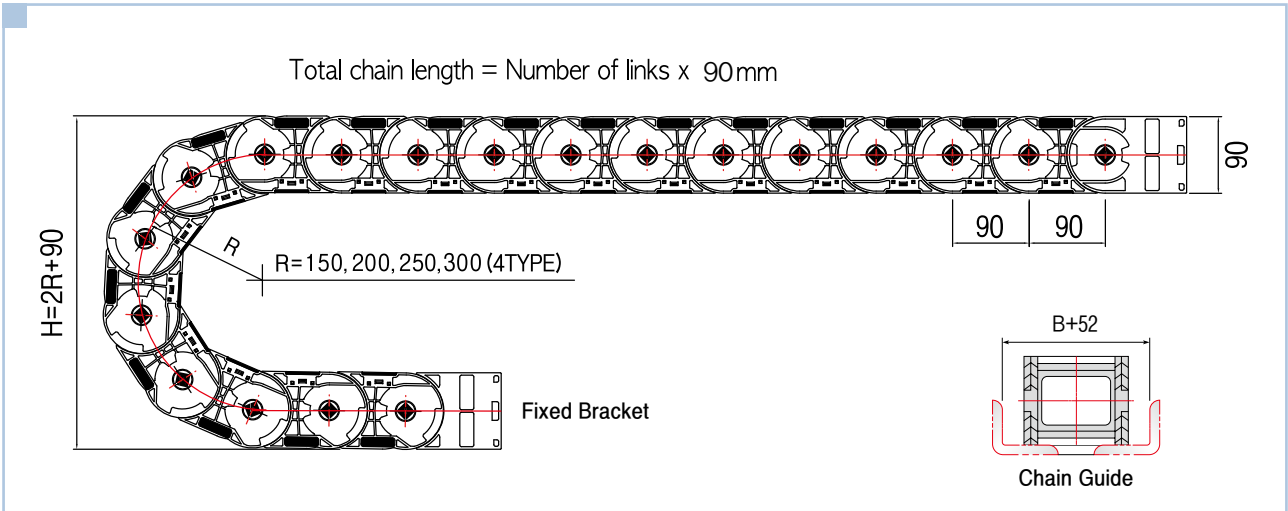

⊕ A-A Cross Section / D.Max

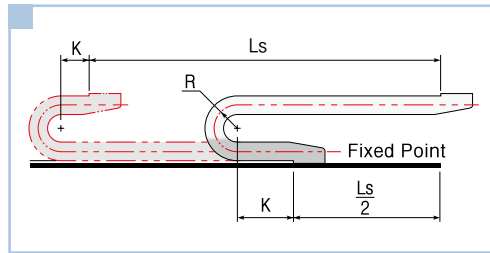
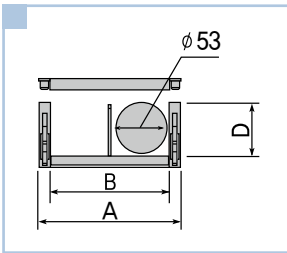

- Chain Length $L = \frac{Ls}{2} + \pi R + 3P(2K)$
- 곡률반경에 따른 H값

R	150	200	250	300
H	390	490	590	690

단위 mm

SERIES	KJS 090-B118	KJS 090-B168	KJS 090-B218	KJS 090-B268
R	150, 200, 250, 300			
A	150	200	250	300
B	118	168	218	268
D	72			

※ Manufacturing Tolerance of ± 10%

⊕ End Bracket (택 1)

Plastic Type

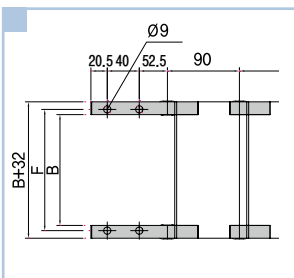

Steel Type

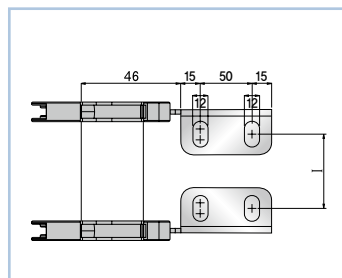

단위 mm

SERIES WITH RODS	F(B+13)	I(B-24)
KJS 090-B118	131	94
KJS 090-B168	181	144
KJS 090-B218	231	194
KJS 090-B268	281	244

⊕ Order Example [주문예]

KJS 090-B118 / Type ➤ R200 / Radius ➤ 40L/K / Length ➤ 10Sets / Q'ty