

TYPE
"_"

REV.NO.	DATE	DESCRIPTION	REV'D BY	CHE'D BY	APP'D BY
△					
△					
△					

SELECTION TABLE

ITEM NO.	LAMP	LAMP SIZE	Q'TY	SUPPLY VOLTAGE	FREQUENCY				
					<input type="checkbox"/> 50Hz	<input type="checkbox"/> 60Hz			
	<input type="checkbox"/> MERCURY VAPOR	<input type="checkbox"/> 70W <input type="checkbox"/> 100W	SET SET	<input type="checkbox"/> AC110V <input type="checkbox"/> AC120V <input type="checkbox"/> AC208V <input type="checkbox"/> AC220V	<input type="checkbox"/> AC230V <input type="checkbox"/> AC240V <input type="checkbox"/> AC277V <input type="checkbox"/>				
	<input type="checkbox"/> H. P. SODIUM								
	<input type="checkbox"/> METAL HALIDE								
				HUB SCHEDULE	THREAD	<input type="checkbox"/> NPT	<input type="checkbox"/> PF	<input type="checkbox"/> MM	<input type="checkbox"/>
					SIZE	<input type="checkbox"/> 3/4"	<input type="checkbox"/> 1"	<input type="checkbox"/> M	<input type="checkbox"/>
					LOCATION	 <input type="checkbox"/> 1-2 <input type="checkbox"/> 1-3 <input type="checkbox"/> 1-2-3 <input type="checkbox"/> 1-2-3-4			
					<input type="checkbox"/> W/2-BLIND PLUGS <input type="checkbox"/> NONE				

NOTE
1.

16	BALLAST HOUSING	CARBON STEEL	
15	BALLAST	FOR H.I.D LAMP	HIGH POWER FACTOR
14	MOUNTING BOX	CAST ALUMINIUM ALLOY	
13	NIPPLE	STEEL	
12	WEATHERPROOF CAP	SILICONE RUBBER	
11	HINGE PIN	ø5 STAINLESS STEEL ROD	SUS304
10	LAMP HOLDER MTG. DEVICE	PHENOL RESIN	
9	LAMP HOLDER	PORCELAIN W/MEDIUM SOCKET	E26
8	BODY	DIE CASTING ALUMINIUM	
7	REFLECTOR	HIGH GRADE ALUMINIUM SHEET	
6	LAMP	H.I.D LAMP	SEE SELECTION TABLE
5	GLOBE RING	DIE CASTING ALUMINIUM	
4	O RING GASKET	SILICONE RUBBER	
3	LOCK RING	DIE CASTING ALUMINIUM	
2	GLOBE	HEAT RESISTANT HARD GLASS	
1	GUARD	ø4 STAINLESS STEEL WIRE	SUS304
NO	PARTS	MATERIAL	REMARK

SCALE	N.S	APPROVED BY	
UNIT	mm	CHECKED BY	
DATE		DRAWN BY	

NB 南北電氣株式會社
NAMBUELECTRIC CO.,LTD

TITLE	H.I.D LTG. FIXTURE (CEILING MTG. TYPE)			APPLICATION AREA	
CAT NO.	EU-L SERIES			CLASS OF PROTECTION	Ex d IIB T*
COLOR FINISHING	MUNSELL NO. 7.5BG 6/1.5			DRAWING NO.	N B - E L H - D 1 - A 0 1

* LENGTH(L) ORDER MADE.

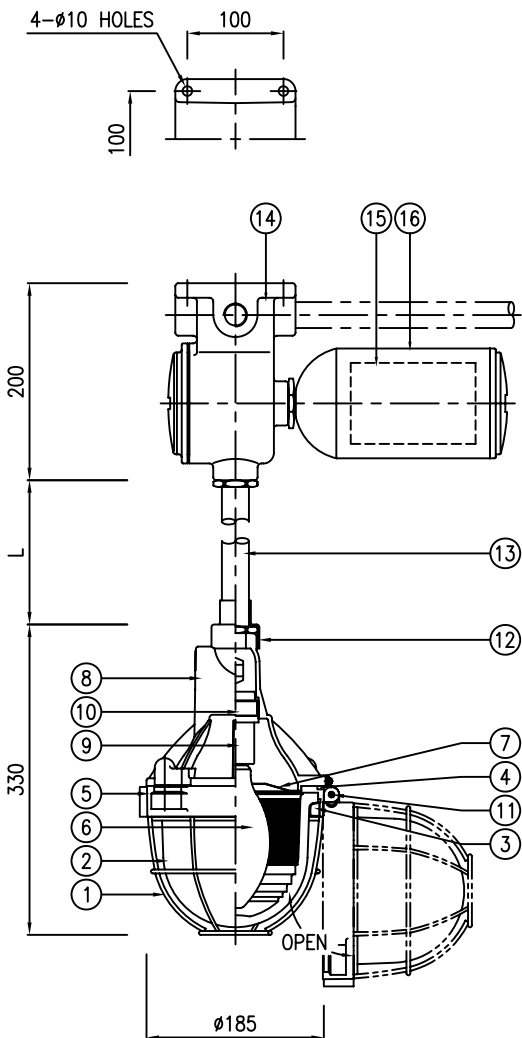

TYPE
"_"

REV.NO.	DATE	DESCRIPTION	REV'D BY	CHE'D BY	APP'D BY
△					
△					
△					

SELECTION TABLE

ITEM NO.	LAMP	LAMP SIZE	Q'TY	SUPPLY VOLTAGE	FREQUENCY				
					<input type="checkbox"/> AC110V	<input type="checkbox"/> AC230V	<input type="checkbox"/> AC240V	<input type="checkbox"/> 50Hz	
	<input type="checkbox"/> MERCURY VAPOR	<input type="checkbox"/> 70W <input type="checkbox"/> 100W	SET SET	<input type="checkbox"/> AC208V <input type="checkbox"/> AC277V <input type="checkbox"/> AC220V	<input type="checkbox"/> AC240V	<input type="checkbox"/> AC277V	<input type="checkbox"/>	<input type="checkbox"/> 60Hz	
	<input type="checkbox"/> H. P. SODIUM								
	<input type="checkbox"/> METAL HALIDE								
				HUB SCHEDULE	THREAD	<input type="checkbox"/> NPT	<input type="checkbox"/> PF	<input type="checkbox"/> MM	<input type="checkbox"/>
					SIZE	<input type="checkbox"/> 3/4"	<input type="checkbox"/> 1"	<input type="checkbox"/> M	<input type="checkbox"/>
					LOCATION	 <input type="checkbox"/> 1-2 <input type="checkbox"/> 1-3 <input type="checkbox"/> 1-2-3 <input type="checkbox"/> 1-2-3-4			
					<input type="checkbox"/> W/2-BLIND PLUGS				<input type="checkbox"/> NONE

NOTE

1.

NO	PARTS	MATERIAL	REMARK
16	BALLAST HOUSING	CARBON STEEL	
15	BALLAST	FOR H.I.D LAMP	HIGH POWER FACTOR
14	MOUNTING BOX	CAST ALUMINIUM ALLOY	
13	SUSPENSION STEM	RIGID STEEL PIPE	
12	WEATHERPROOF CAP	SILICONE RUBBER	
11	HINGE PIN	φ5 STAINLESS STEEL ROD	SUS304
10	LAMP HOLDER MTG. DEVICE	PHENOL RESIN	
9	LAMP HOLDER	PORCELAIN W/MEDIUM SOCKET	E26
8	BODY	DIE CASTING ALUMINIUM	
7	REFLECTOR	HIGH GRADE ALUMINIUM SHEET	
6	LAMP	H.I.D LAMP	SEE SELECTION TABLE
5	GLOBE RING	DIE CASTING ALUMINIUM	
4	O RING GASKET	SILICONE RUBBER	
3	LOCK RING	DIE CASTING ALUMINIUM	
2	GLOBE	HEAT RESISTANT HARD GLASS	
1	GUARD	φ4 STAINLESS STEEL WIRE	SUS304

SCALE	N.S	APPROVED BY	
UNIT	mm	CHECKED BY	
DATE		DRAWN BY	

NB 南北電氣株式會社
NAMBUK ELECTRIC CO.,LTD

TITLE	H.I.D LTG. FIXTURE (PENDANT MTG. TYPE)		APPLICATION AREA	
CAT NO.	EU-L SERIES		CLASS OF PROTECTION	Ex d IIB T*
COLOR FINISHING	MUNSELL NO. 7.5BG 6/1.5		DRAWING NO.	N B - E L H - D 1 - A 0 1

REV.NO.	DATE	DESCRIPTION	REV'D BY	CHE'D BY	APP'D BY
△					
△					
△					

SELECTION TABLE

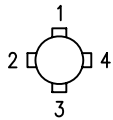
ITEM NO.	LAMP	LAMP SIZE	Q'TY	SUPPLY VOLTAGE	FREQUENCY				
					<input type="checkbox"/> AC110V	<input type="checkbox"/> AC230V	<input type="checkbox"/> AC240V	<input type="checkbox"/> 50Hz	
	<input type="checkbox"/> MERCURY VAPOR	<input type="checkbox"/> 70W <input type="checkbox"/> 100W	SET SET	<input type="checkbox"/> AC120V <input type="checkbox"/> AC208V <input type="checkbox"/> AC220V	<input type="checkbox"/> AC277V	<input type="checkbox"/>	<input type="checkbox"/> 60Hz		
	<input type="checkbox"/> H. P. SODIUM								
	<input type="checkbox"/> METAL HALIDE								
				HUB SCHEDULE	THREAD	<input type="checkbox"/> NPT	<input type="checkbox"/> PF	<input type="checkbox"/> MM	<input type="checkbox"/>
					SIZE	<input type="checkbox"/> 3/4"	<input type="checkbox"/> 1"	<input type="checkbox"/> M	<input type="checkbox"/>
					LOCATION	 <input type="checkbox"/> 1-2 <input type="checkbox"/> 1-3 <input type="checkbox"/> 1-2-3 <input type="checkbox"/> 1-2-3-4			
					<input type="checkbox"/> W/2-BLIND PLUGS				<input type="checkbox"/> NONE

NOTE
1.

16	BALLAST HOUSING	CARBON STEEL	
15	BALLAST	FOR H.I.D LAMP	HIGH POWER FACTOR
14	MOUNTING BOX	CAST ALUMINIUM ALLOY	
13	SUSPENSION STEM	RIGID STEEL PIPE	
12	WEATHERPROOF CAP	SILICONE RUBBER	
11	HINGE PIN	ø5 STAINLESS STEEL ROD	SUS304
10	LAMP HOLDER MTG. DEVICE	PHENOL RESIN	
9	LAMP HOLDER	PORCELAIN W/MEDIUM SOCKET	E26
8	BODY	DIE CASTING ALUMINIUM	
7	REFLECTOR	HIGH GRADE ALUMINIUM SHEET	
6	LAMP	H.I.D LAMP	SEE SELECTION TABLE
5	GLOBE RING	DIE CASTING ALUMINIUM	
4	O RING GASKET	SILICONE RUBBER	
3	LOCK RING	DIE CASTING ALUMINIUM	
2	GLOBE	HEAT RESISTANT HARD GLASS	
1	GUARD	ø4 STAINLESS STEEL WIRE	SUS304
NO	PARTS	MATERIAL	REMARK

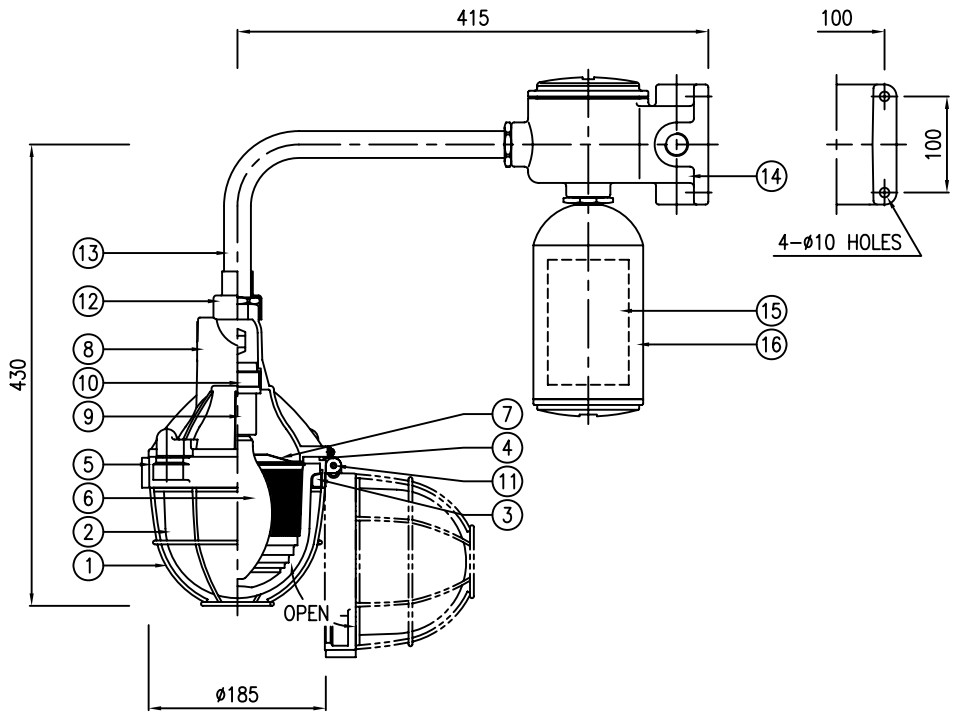

TYPE
"_"

SCALE	N.S	APPROVED BY	
UNIT	mm	CHECKED BY	
DATE		DRAWN BY	

NB 南北電氣株式會社
NAMBUK ELECTRIC CO.,LTD

TITLE	H.I.D LTG. FIXTURE (BRACKET MTG. TYPE)		APPLICATION AREA	
CAT NO.	EU-L SERIES		CLASS OF PROTECTION	Ex d IIB T*
COLOR FINISHING	MUNSELL NO. 7.5BG 6/1.5		DRAWING NO.	N B - E L H - D 1 - - A 0 1

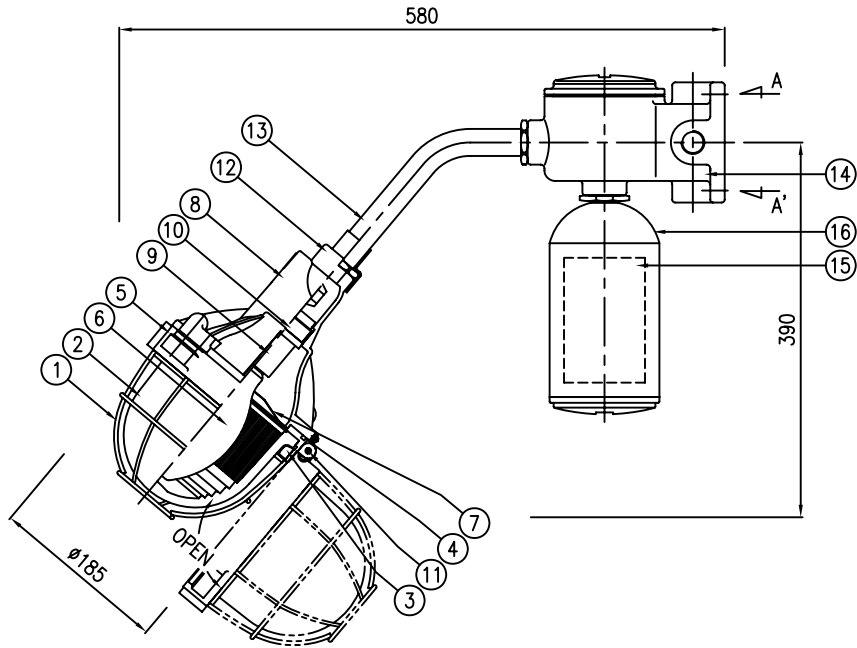
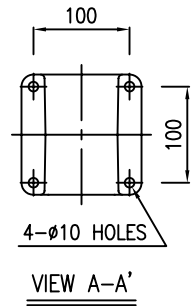

TYPE
"_"

REV.NO.	DATE	DESCRIPTION	REV'D BY	CHE'D BY	APP'D BY
△					
△					
△					

SELECTION TABLE

ITEM NO.	LAMP	LAMP SIZE	Q'TY	SUPPLY VOLTAGE	FREQUENCY	
					□ 50Hz	□ 60Hz
	<input type="checkbox"/> MERCURY VAPOR	<input type="checkbox"/> 70W <input type="checkbox"/> 100W	SET SET	<input type="checkbox"/> AC110V <input type="checkbox"/> AC120V <input type="checkbox"/> AC208V <input type="checkbox"/> AC220V	<input type="checkbox"/> AC230V <input type="checkbox"/> AC240V <input type="checkbox"/> AC277V <input type="checkbox"/>	
	<input type="checkbox"/> H. P. SODIUM					
	<input type="checkbox"/> METAL HALIDE					
				HUB SCHEDULE	THREAD	<input type="checkbox"/> NPT <input type="checkbox"/> PF <input type="checkbox"/> MM <input type="checkbox"/>
					SIZE	<input type="checkbox"/> 3/4" <input type="checkbox"/> 1" <input type="checkbox"/> M <input type="checkbox"/>
				HUB SCHEDULE	LOCATION	
						<input type="checkbox"/> W/2-BLIND PLUGS <input type="checkbox"/> NONE

NOTE

1.

NO	PARTS	MATERIAL	REMARK
16	BALLAST HOUSING	CARBON STEEL	
15	BALLAST	FOR H.I.D LAMP	HIGH POWER FACTOR
14	MOUNTING BOX	CAST ALUMINIUM ALLOY	
13	SUSPENSION STEM	RIGID STEEL PIPE	
12	WEATHERPROOF CAP	SILICONE RUBBER	
11	HINGE PIN	φ5 STAINLESS STEEL ROD	SUS304
10	LAMP HOLDER MTG. DEVICE	PHENOL RESIN	
9	LAMP HOLDER	PORCELAIN W/MEDIUM SOCKET	E26
8	BODY	DIE CASTING ALUMINIUM	
7	REFLECTOR	HIGH GRADE ALUMINIUM SHEET	
6	LAMP	H.I.D LAMP	SEE SELECTION TABLE
5	GLOBE RING	DIE CASTING ALUMINIUM	
4	O RING GASKET	SILICONE RUBBER	
3	LOCK RING	DIE CASTING ALUMINIUM	
2	GLOBE	HEAT RESISTANT HARD GLASS	
1	GUARD	φ4 STAINLESS STEEL WIRE	SUS304

SCALE	N.S	APPROVED BY	
UNIT	mm	CHECKED BY	
DATE		DRAWN BY	

NB 南北電氣株式會社
NAMBUK ELECTRIC CO.,LTD

TITLE	H.I.D LTG. FIXTURE (40" BRACKET MTG. TYPE)		APPLICATION AREA	
CAT NO.	EU-L SERIES		CLASS OF PROTECTION	Ex d IIB T*
COLOR FINISHING	MUNSELL NO. 7.5BG 6/1.5		DRAWING NO.	N B - E L H - D 1 - A 0 1

* LENGTH(L) ORDER MADE.

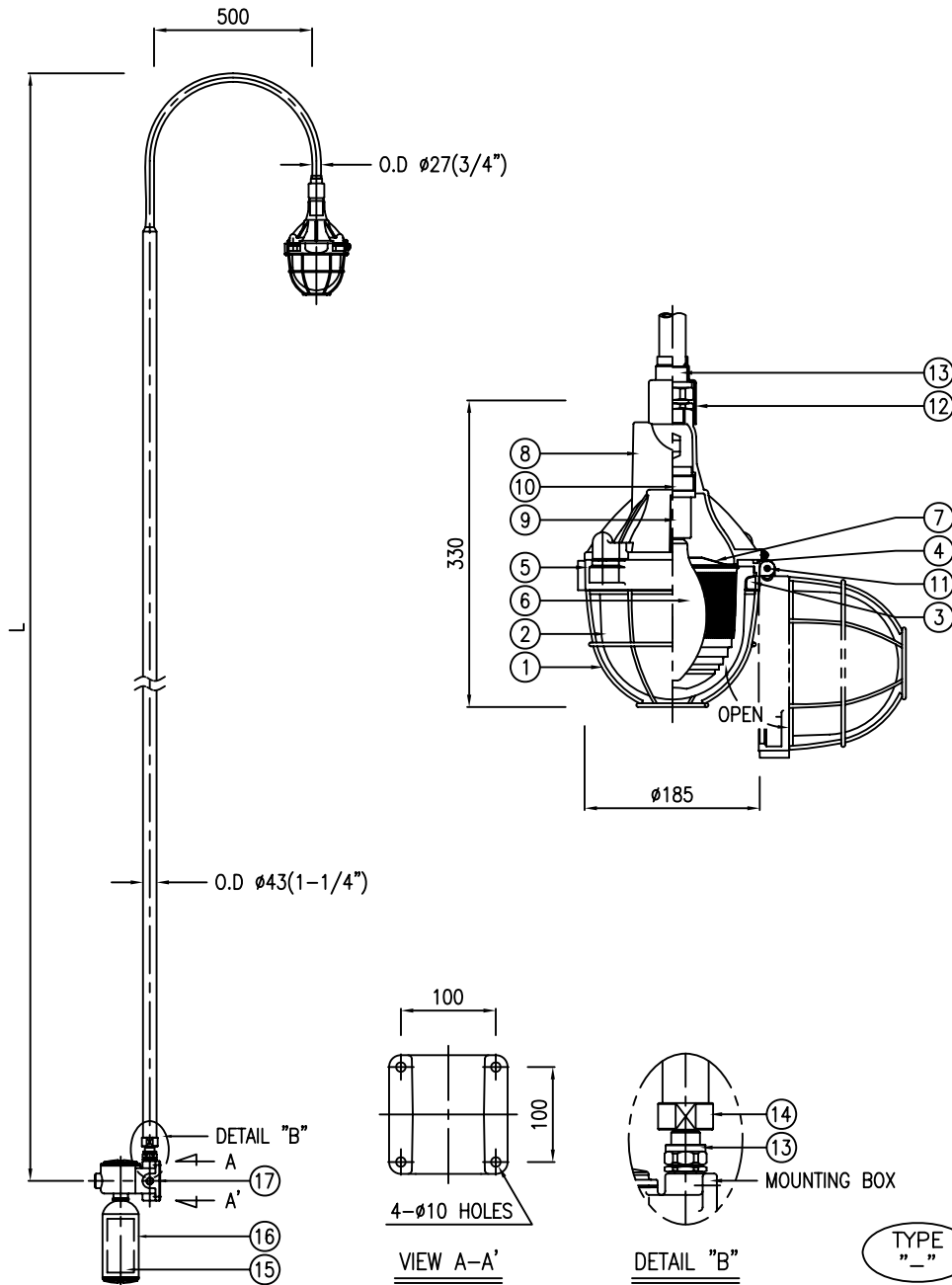

REV.NO.	DATE	DESCRIPTION	REV'D BY	CHE'D BY	APP'D BY
△					
△					
△					

SELECTION TABLE

ITEM NO.	LAMP	LAMP SIZE	Q'TY	SUPPLY VOLTAGE		FREQUENCY		
				<input type="checkbox"/> AC110V <input type="checkbox"/> AC120V <input type="checkbox"/> AC208V <input type="checkbox"/> AC220V	<input type="checkbox"/> AC230V <input type="checkbox"/> AC240V <input type="checkbox"/> AC277V <input type="checkbox"/>	<input type="checkbox"/> 50Hz <input type="checkbox"/> 60Hz		
	<input type="checkbox"/> MERCURY VAPOR	<input type="checkbox"/> 70W <input type="checkbox"/> 100W	SET SET	HUB SCHEDULE	THREAD	<input type="checkbox"/> NPT <input type="checkbox"/> PF <input type="checkbox"/> MM	<input type="checkbox"/>	
	<input type="checkbox"/> H. P. SODIUM				SIZE	<input type="checkbox"/> 3/4" <input type="checkbox"/> 1"	<input type="checkbox"/> M <input type="checkbox"/>	
	<input type="checkbox"/> METAL HALIDE				LOCATION	POLE		<input type="checkbox"/> P-1 <input type="checkbox"/> P-2 <input type="checkbox"/> P-1-2 <input type="checkbox"/> P-1-2-3
						<input type="checkbox"/> W/2-BLIND PLUGS <input type="checkbox"/> NONE		

NOTE
1.

NO	PARTS	MATERIAL	REMARK
17	MOUNTING BOX	CAST ALUMINIUM ALLOY	
16	BALLAST HOUSING	CARBON STEEL	
15	BALLAST	FOR H.I.D LAMP	HIGH POWER FACTOR
14	SOCKET	CARBON STEEL	
13	UNION COUPLING	CARBON STEEL	
12	WEATHERPROOF CAP	SILICONE RUBBER	
11	HINGE PIN	φ5 STAINLESS STEEL ROD	SUS304
10	LAMP HOLDER MTG. DEVICE	PHENOL RESIN	
9	LAMP HOLDER	PORCELAIN W/MEDIUM SOCKET	E26
8	BODY	DIE CASTING ALUMINIUM	
7	REFLECTOR	HIGH GRADE ALUMINIUM SHEET	
6	LAMP	H.I.D LAMP	SEE SELECTION TABLE
5	GLOBE RING	DIE CASTING ALUMINIUM	
4	O RING GASKET	SILICONE RUBBER	
3	LOCK RING	DIE CASTING ALUMINIUM	
2	GLOBE	HEAT RESISTANT HARD GLASS	
1	GUARD	φ4 STAINLESS STEEL WIRE	SUS304

SCALE	N.S	APPROVED BY	
UNIT	mm	CHECKED BY	
DATE		DRAWN BY	

南北電氣株式會社
NAMBUK ELECTRIC CO.,LTD

TITLE	H.I.D LTG. FIXTURE (HAND RAIL TYPE)	APPLICATION AREA	
CAT NO.	EU-L SERIES	CLASS OF PROTECTION	Ex d IIB T*
COLOR FINISHING	LTG. FIXTURE : MUNSELL NO. 7.5BG 6/1.5 POLE : HOT DIP GALVANIZED	DRAWING NO.	N B - E L H - D 1 - A 0 1