

# BS-TYPE

**“NEW”**

**FEATURES ;**

- Accuracy guaranteed to 0,002 mm TIR(0,0001” ).
- Excellent for grinders and CNC lathes.
- Heat-treated point to HRc 60±2.
- Two angular contact bearings for superior performance.
- Anti-friction seal for coolant deflectors and high speed.
- High RPM, up to 6,000.
- Heat-treated body for extra strength, rigidity and long life.

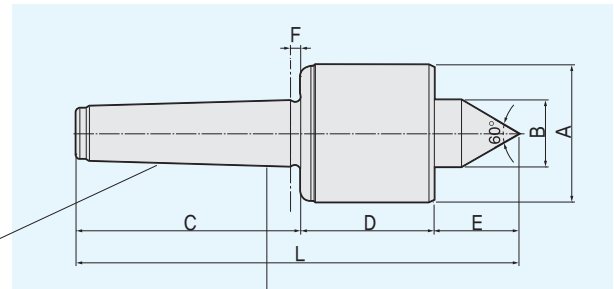

Shaft borehole for easy efficient dismounting

Drop-forged body for long life  
HRc. 50±2

**Dimension**

16	1	0	0	MT								
MODEL	MT	A	B	C	D	E	F	L	W.P Weight	Max, R.P.M	Weight	Max, Run Out
161003	3	50	20	85	58	23	4,5	166	750	6,000	1,9	0,002
161004	4	66	30	108	71	35	5,3	214	1,400	6,000	2,4	0,002
161005	5	80	35	136	76	38	6,3	250	2,500	5,000	5,3	0,002

Unit : mm, kg

# BSC-TYPE

“NEW”

## FEATURES ;

- Accuracy guaranteed to 0,002mm TIR(0,0001” ).
- Excellent for grinders and CNC lathes.
- Heat-treated point to HRc 90±2.
- Two angular contact bearings for superior performance.
- Anti-friction seal for coolant deflectors and high speed.
- High RPM, up to 6,000.
- Heat-treated body for extra strength, rigidity and long life.

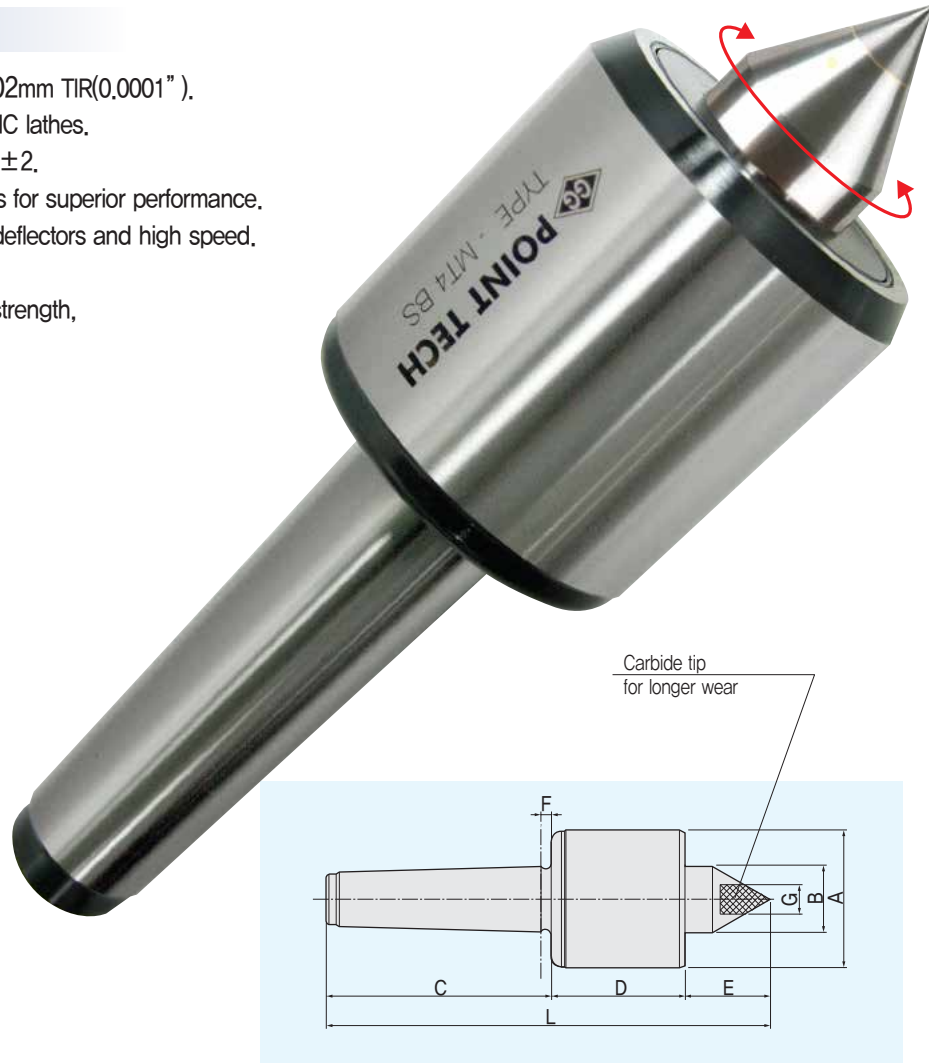

## Dimension

16	2	0	0	MT	Unit : mm, kg								
MODEL	MT	A	B	C	D	E	F	G	L	W.P Weight	Max, R.P.M	Weight	Max, Run Out
162003	3	50	22	85	58	23	4.5	10	166	750	6,000	1.9	0.002
162004	4	66	30	108	71	35	5.3	14	214	1,400	6,000	2.4	0.002
162005	5	80	35	136	76	38	6.3	18	250	2,500	5,000	5.3	0.002

# BSL30-TYPE

**“NEW”**

**FEATURES :**

- Accuracy guaranteed to 0,002mm TIR(0,0001” ).
- Excellent for grinders and CNC lathes.
- Heat-treated point to HRC 60±2.
- Three angular contact bearings for superior performance.
- Anti-friction seal for coolant deflectors and high speed.
- High RPM, up to 6,000.
- Heat-treated body for extra strength, rigidity and long life.

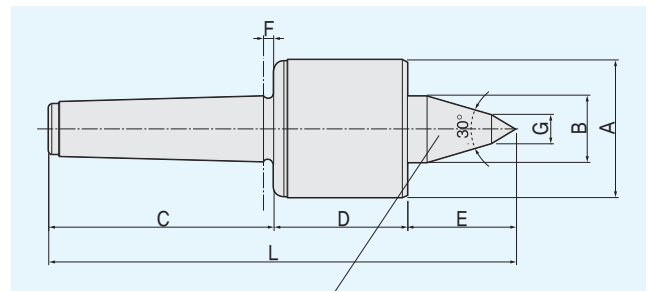
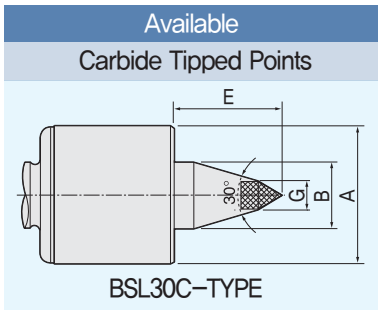

30° point is specially shaped for improved tool clearance

**Dimension**

16	3	0	0	MT									
MODEL	MT	A	B	C	D	E	F	G	L	W,P Weight	Max, R.P.M	Weight	Max, Run Out
163003	3	50	20	85	58	31	4.5	10	174	750	6,000	1.9	0,002
163004	4	66	30	108	71	51	5.3	14	230	1,400	6,000	2.4	0,002
163005	5	80	35	136	76	53	6.3	18	265	2,500	5,000	5.3	0,002

Unit : mm, kg

# BSL30A-TYPE

“NEW”

## FEATURES ;

- Accuracy guaranteed to 0,002mm TIR(0,0001” ).
- Excellent for grinders and CNC lathes.
- Heat-treated point to HRc 60±2.
- Three angular contact bearings for superior performance.
- Anti-friction seal for coolant deflectors and high speed.
- High RPM, up to 6,000.
- Heat-treated body for extra strength, rigidity and long life

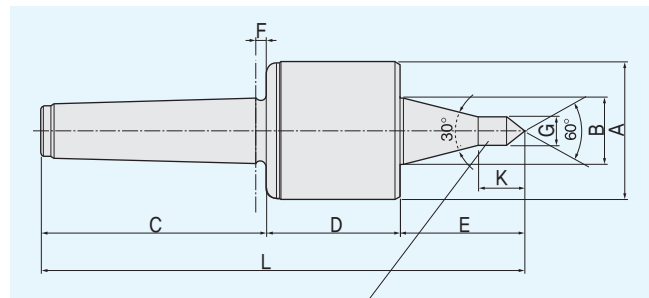
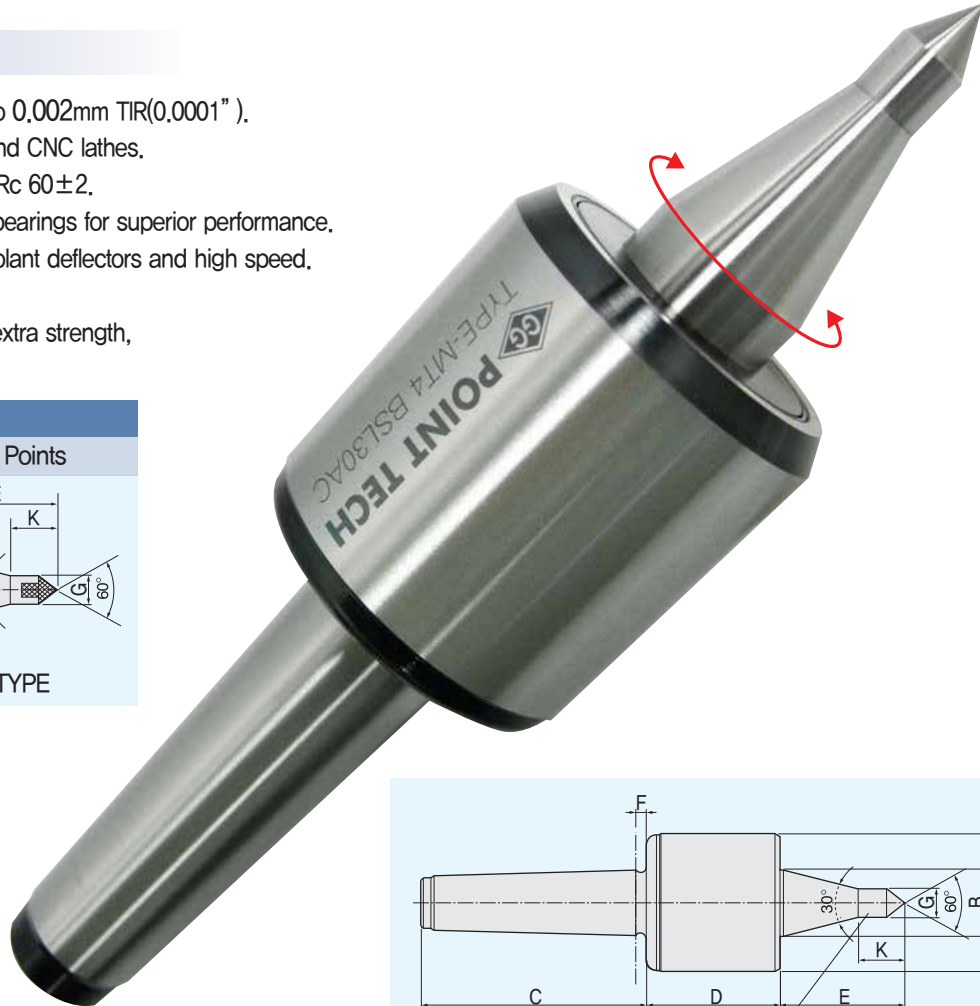
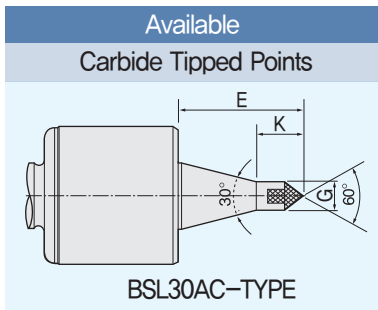

Elongated center point is specially shaped for improved tool clearance(Diagram)

## Dimension

16	5	0	0	MT											Unit : mm, kg	
MODEL	MT	A	B	C	D	E	F	G	K	L	W.P Weight	Max, R.P.M	Weight	Max, Run Out		
165003	3	50	20	85	58	37	4.5	10	15	180	750	6,000	1.9	0.002		
165004	4	66	30	108	71	63.5	5.3	12.5	23	242.5	1,400	6,000	2.4	0.002		
165005	5	80	35	136	76	70	6.3	12.5	23.5	282	2,500	5,000	5.3	0.002		