

FD Finger Chuck

핑거 척



제품 특징

내·외경 클램핑이 불가능하거나 내·외경 변경이 우려되는 공작물에 적합

주요 기술

가공물의 두께편차에 대한 플로팅 기능
2조, 3조, 4조 모두 사용가능

Application / Customer's Benefit

Ideal for gripping workpieces that are impossible to grip from the inner and outer diameter or where deformations are likely to occur.

Technical features

Floating clamping fingers adjust to workpiece shape
Available in 2-jaw, 3-jaw, and 4-jaw models

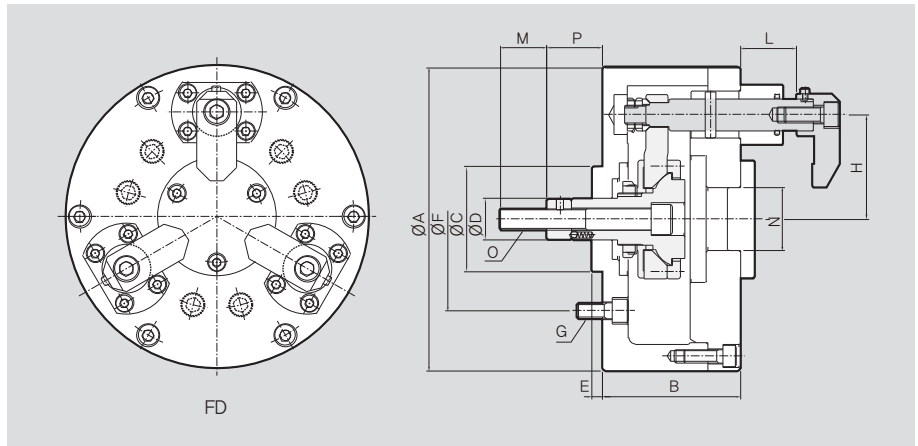
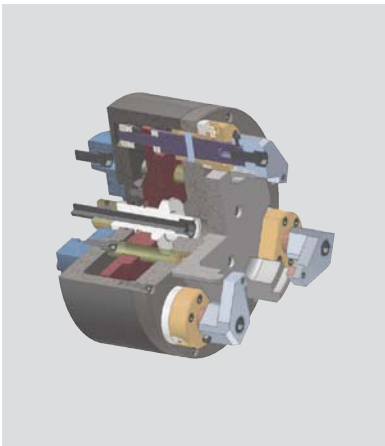

제품 치수 / DIMENSIONS

	FD-06	FD-08	FD-10	FD-12	FD-15	FD-18
ΦA	165	210	254	304	381	457
B	75	85	95	110	125	140
ΦC(h7)	60	80	120	120	150	150
ΦD	35	42	52	52	55	55
E	7	7	7	7	7	7
ΦF	104.8	133.4	171.4	171.4	230	230
G	M10	M12	M16	M16	M20	M20
H	55	75	95	120	155	192
ΦLmax.	54	59	72	72	84	84
ΦLmin.	30	35	40	45	50	50
M	36	36	46	46	50	50
ΦN	40	45	55	55	60	60
O	M16	M20	M24	M24	M27	M27
Pmax.	44	50	60	60	75	75
Pmin.	30	35	40	40	50	50

제품 사양 / SPECIFICATIONS

		FD-06	FD-08	FD-10	FD-12	FD-15	FD-18
최대 파악력 [kgf]	Max. Clamping Force	1400	2100	2800	2800	3600	3600
최대 인장력 [kgf]	Max. Drawbar Pull	1800	2700	3600	3600	4500	4500
조스트로크 직경 [mm]	Jaw Stroke Dia.	2	2	2	2	2	2
플런저 스트로크 [mm]	Plunger Stroke	14	15	20	20	20	25
파악경 [mm]	Clamping Range	Max.	75	110	145	195	330
		Min.	30	50	60	110	180
최대 회전속도 [r.p.m.]	Max. Speed	3500	2800	2400	2100	1800	1500
무게 [kg]	Weight	9	18	30	41	73	102
관성모멘트 [kgf · m ²]	GD2	0.12	0.41	1.05	2.17	5.65	11.6