

HRS-204, 254i

Controller Type Hydraulic NC Rotary Table



- High Precision, High Speed Systems
- Vertical & Horizontal available
- Compact Design
- Extremely Rigid Body
- Realize High Clamping Force by applying Double Piston

HRS-SERIES

Model No. **HRS-204**

Table Diameter
TYPE : Hydraulic Single Spindle NC Rotary Table

HRS-204

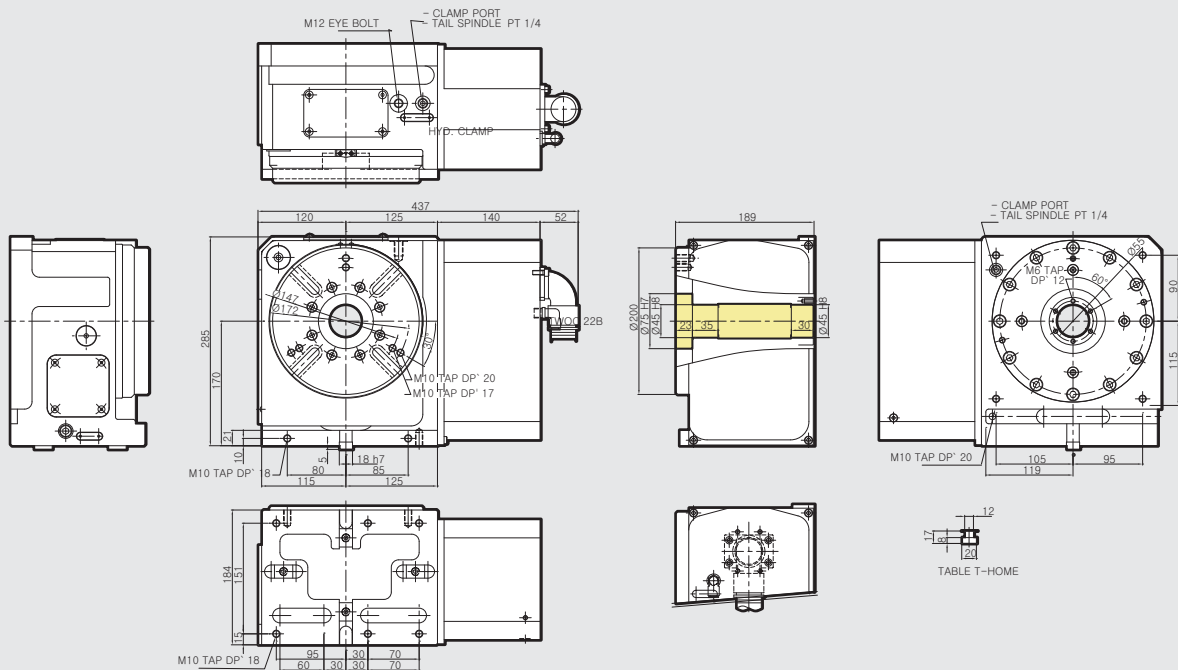

HRS-254i

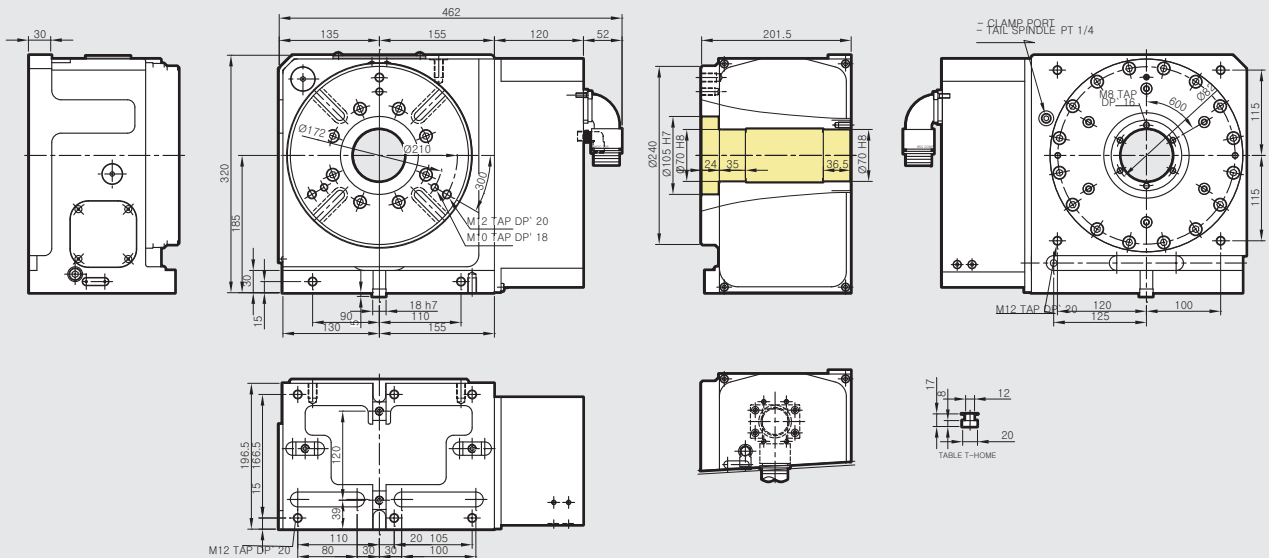

HRS-324i

Controller Type Hydraulic NC Rotary Table



- High Precision, High Speed Systems
- Vertical & Horizontal available
- Compact Design
- Extremely Rigid Body
- Realize High Clamping Force by applying Double Piston

HRS-SERIES

Model No. **HRS-324 i**

Motor Spec (None : 1HP, i : 2HP)
Table Diameter
TYPE : Hydraulic Single Spindle NC Rotary Table

HRS-324i

