

IPk 성능곡선

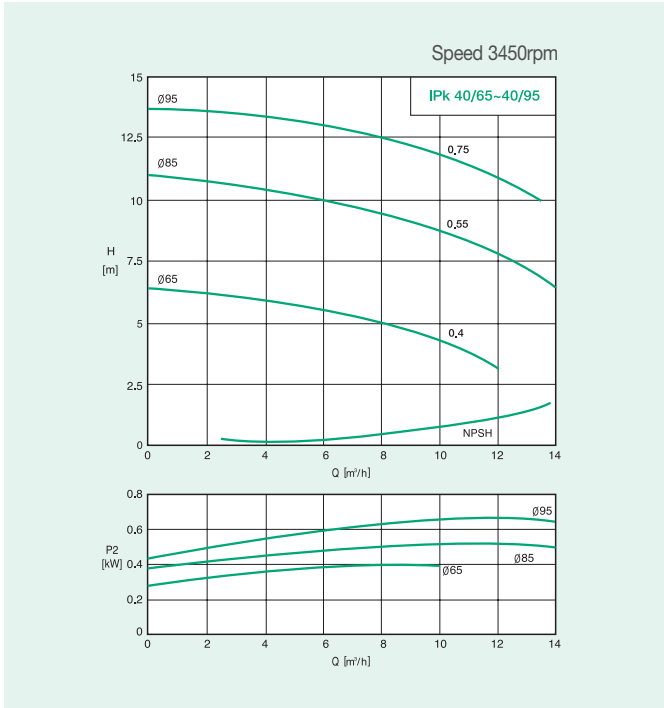

외형도

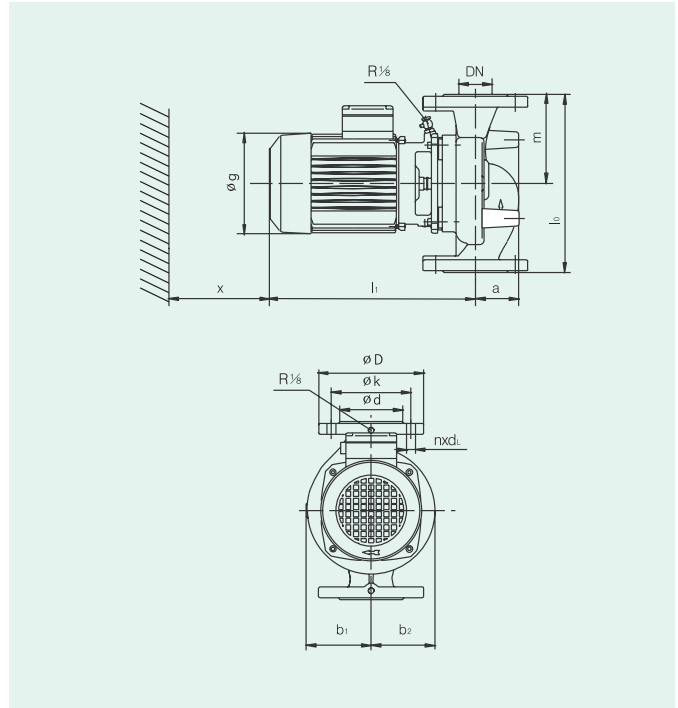

플랜지 규격

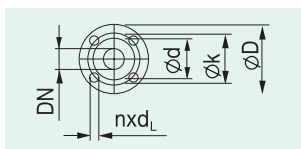

PN 16-EN1092-2					
모델	구경	펌프 플랜지			
	DN	D	d	k	n x dL
IPk 40	40	150	88	110	4 x 18

외형치수 (IPk 40/65~40/95)

모델	외 형 치 수									무게	모터
	l0	a	b1	b2	b3	g	l1	m	x		동력
	mm										kg
IPk 40/65-0.4/2	250	75	90	80	207	152	350	125	150	20	0.4
IPk 40/85-0.55/2											0.55
IPk 40/95-0.75/2											0.75

*IPk 40/65-0.4/2는 단상 Motor임.(전원 1~220V, 60Hz)

*IPk series는 Option 적용 불가함.

In-Line Pumps

IP-E/DP-E Series

WILO

제품소개



WILO-IP-E/DP-E

전자제어 인라인 펌프

모델명

- 예) IP-E 32/160-1,1/2
- IP-E : 전자제어 인라인펌프
 - DP-E : 듀얼 전자제어 인라인펌프
 - 32/ : 플랜지 구경(mm)
 - 160 : 공칭 임펠러외경(mm)
 - 1,1/2 : 모터동력(kW) /극수

적용범위

냉 · 온수 순환, 난방순환용 등에 사용되며,
글리콜 10%의 액체까지 사용이 가능

구조

- 펌프하우징
구형 볼류트를 가지고 있고, 흡·토출 배관이 인라인에 위치합니다.
펌프의 차압을 측정할 수 있도록 플랜지에 1/8" Tap 가공하여
차압센서를 부착하였습니다.
- 미캐니컬 실
용액 온도 120℃까지 사용 가능하며 40℃의 온도까지는 글리콜
20~40% 용액까지 사용가능합니다.

기술자료

- 허용유체
VDI 2035에 적합한 유체
냉수/냉각수
- 성능
무단변속
최고 사용 압력 : 10bar
온도범위 : -10℃ ~ +120℃
전 원 : 3~380V, 60Hz/3~400V, 50Hz
- 배관 연결
구 경 : DN32~DN80
(PN16/EN 1092-2)
- 주위온도
최고온도 : +40℃
- 재 질
펌프케이싱 : Gray Cast Iron
어댑터 : Gray Cast Iron
임펠러 : Engineering Plastic
샤프트 : Stainless Steel
미캐니컬 실 : AQ, EGG
- Motor 방식
보호계급 : IP55
절연계급 : F

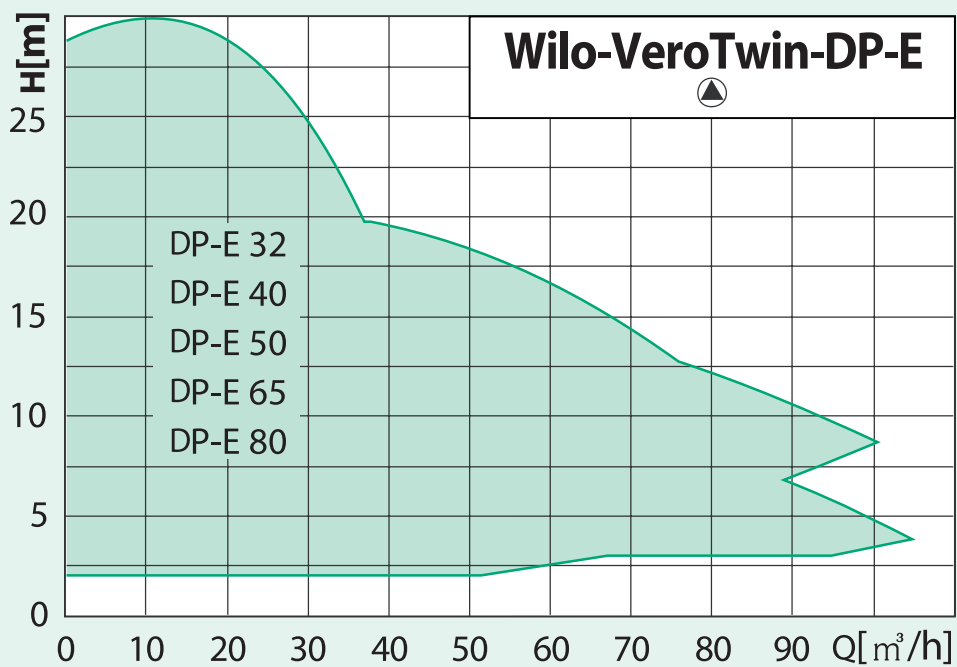
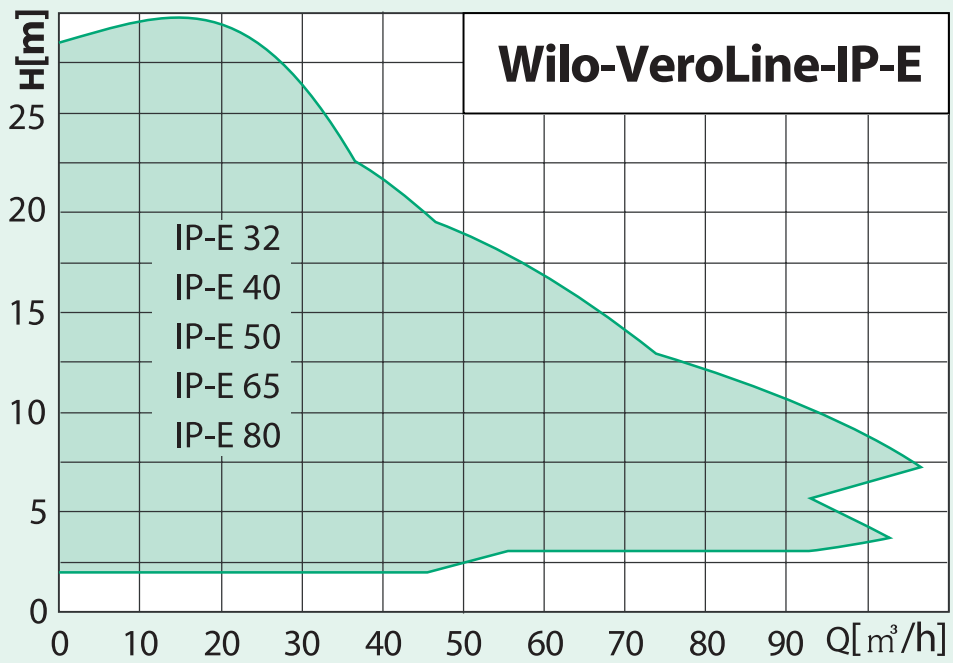

In-Line Pumps

IP-E Series



성능곡선

IP-E 32/160-1.1/2

Δp -c (constant)

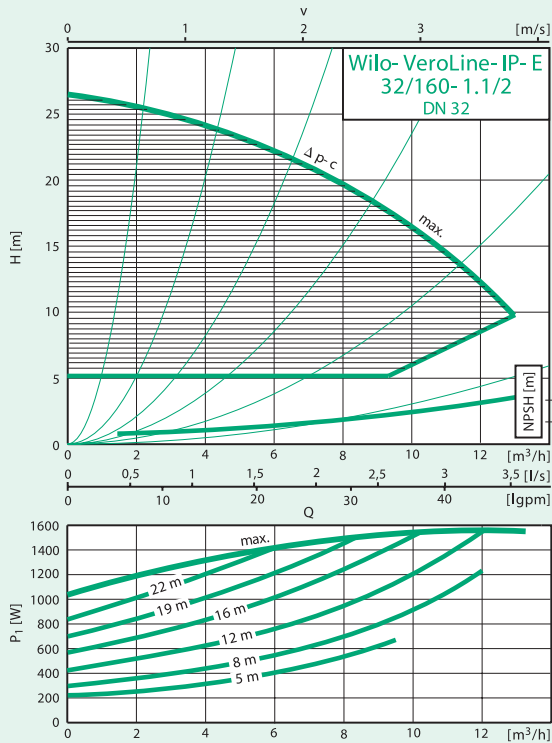

Δp -v (variable)

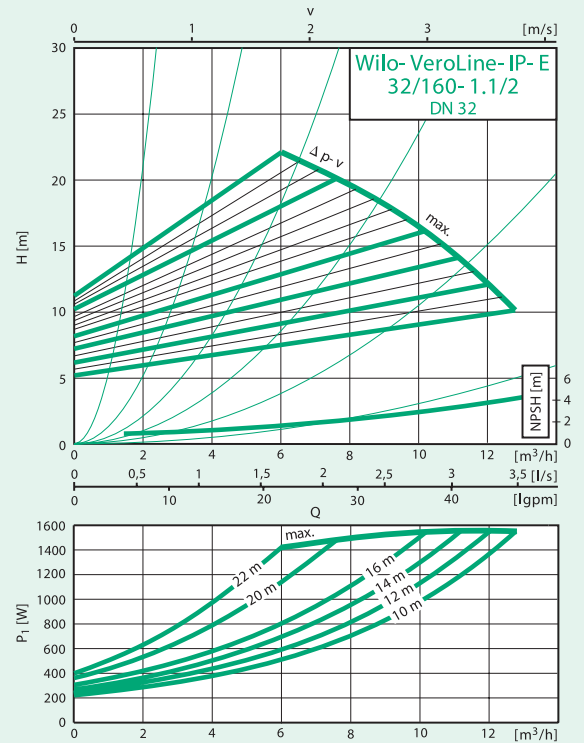

IP-E 40/115-0.55/2

Δp -c (constant)

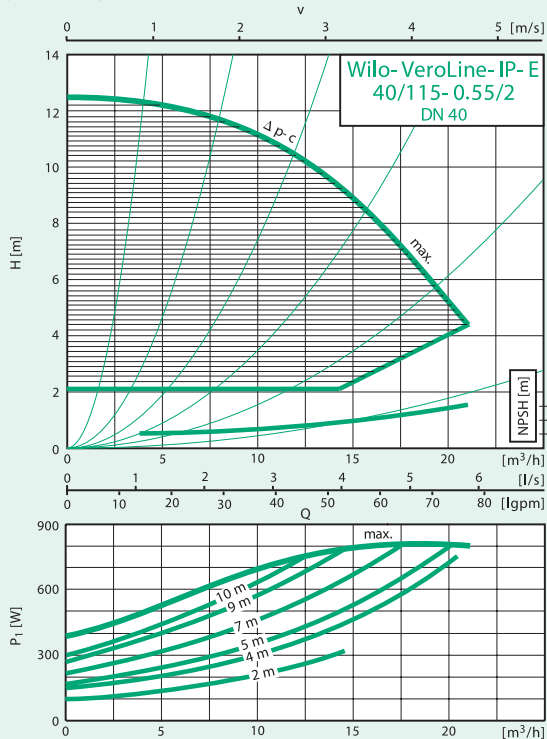

Δp -v (variable)

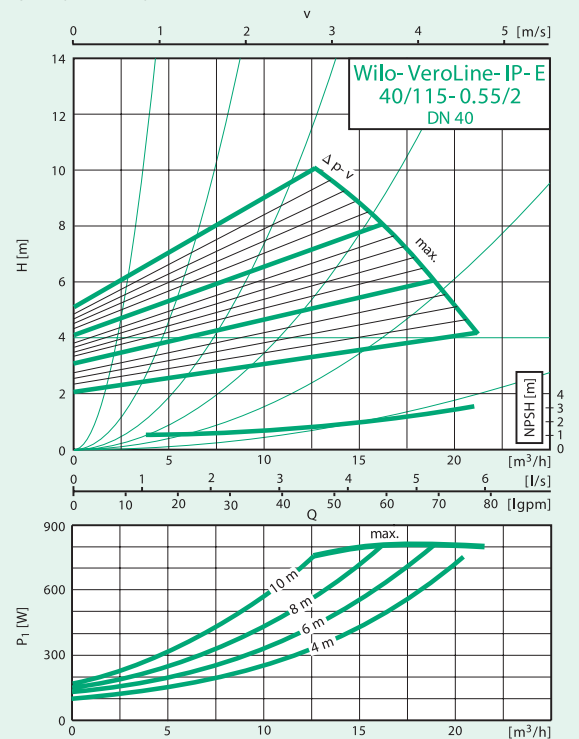

IP-E 40/150-3/2

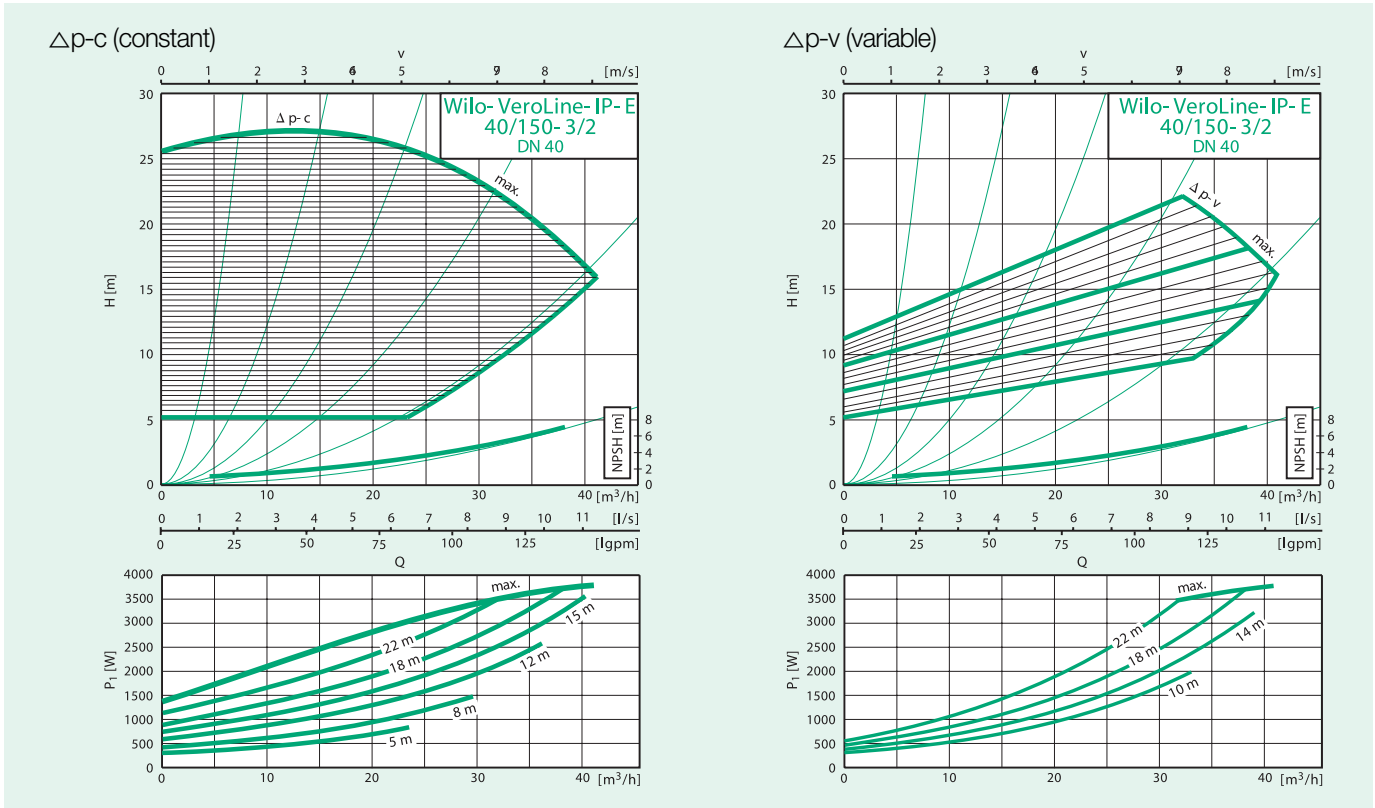

IP-E 40/160-4/2

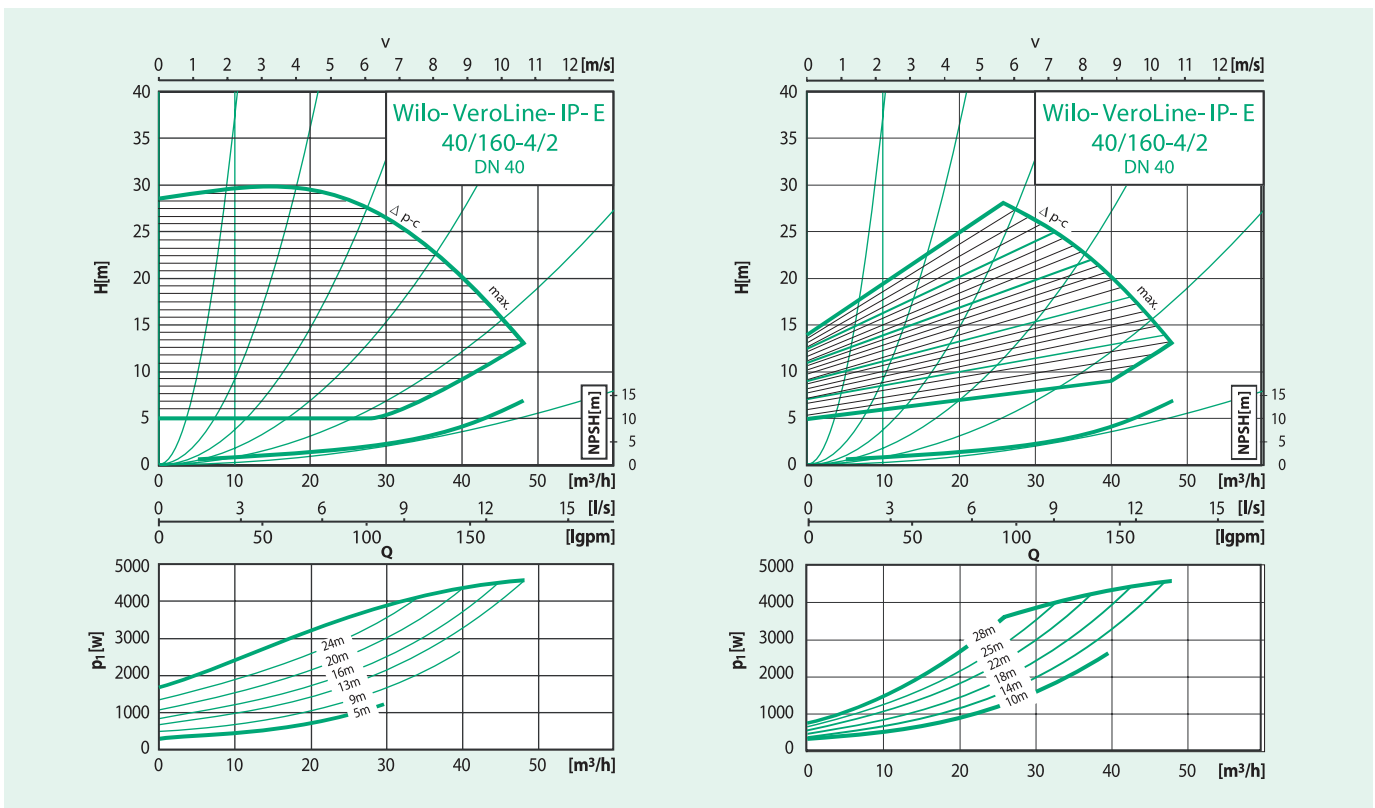

In-Line Pumps

IP-E Series



성능곡선

IP-E 50/115-0.75/2

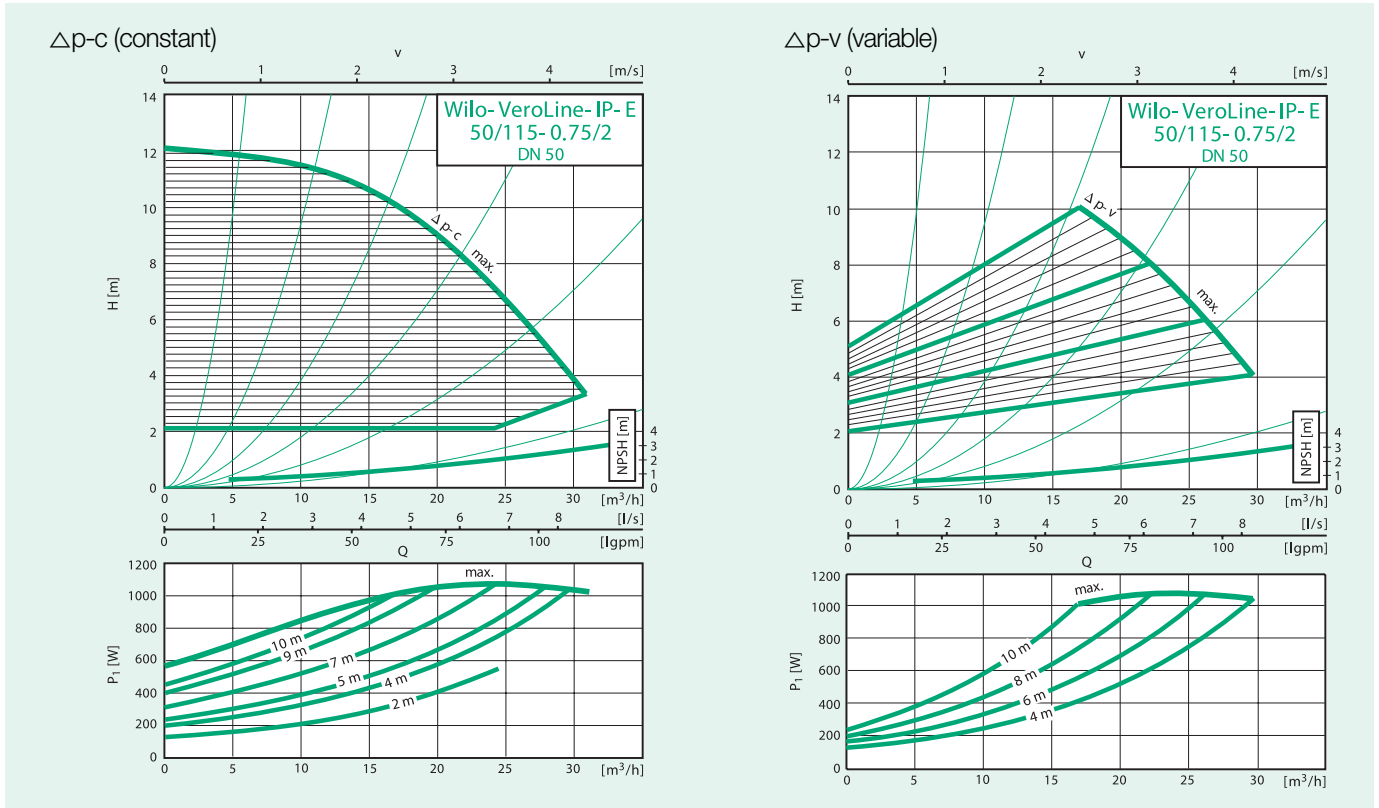

IP-E 50/140-3/2

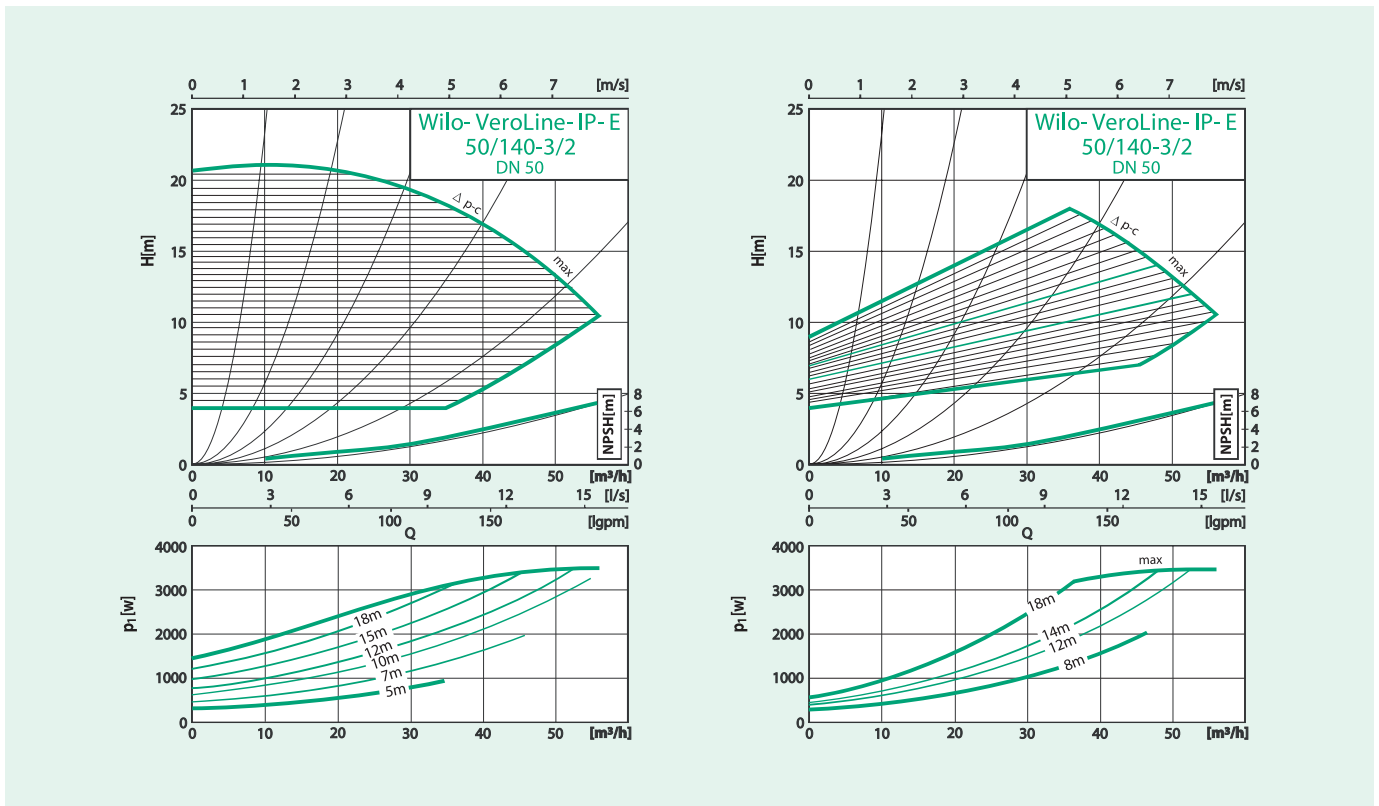

IP-E 50/150-4/2

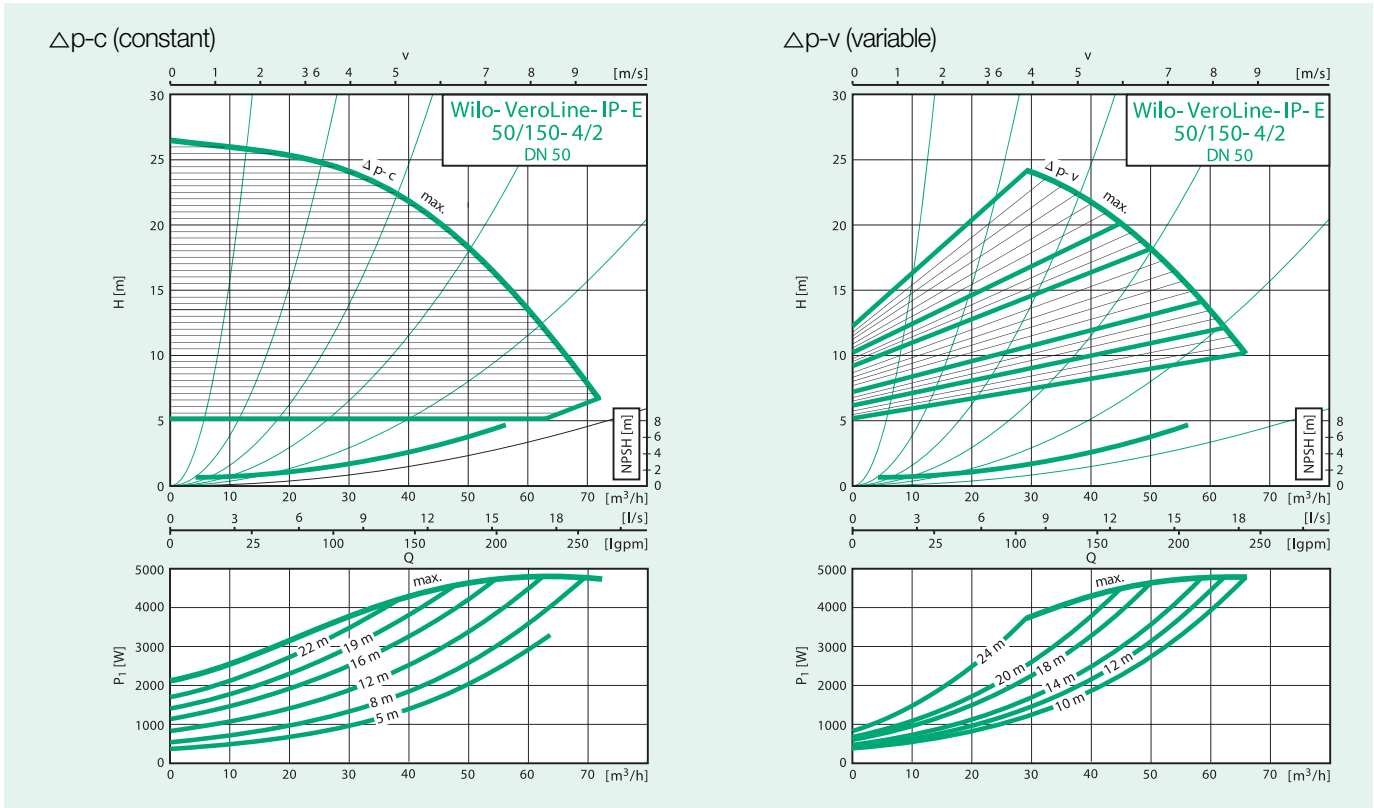

IP-E 65/115-1.5/2

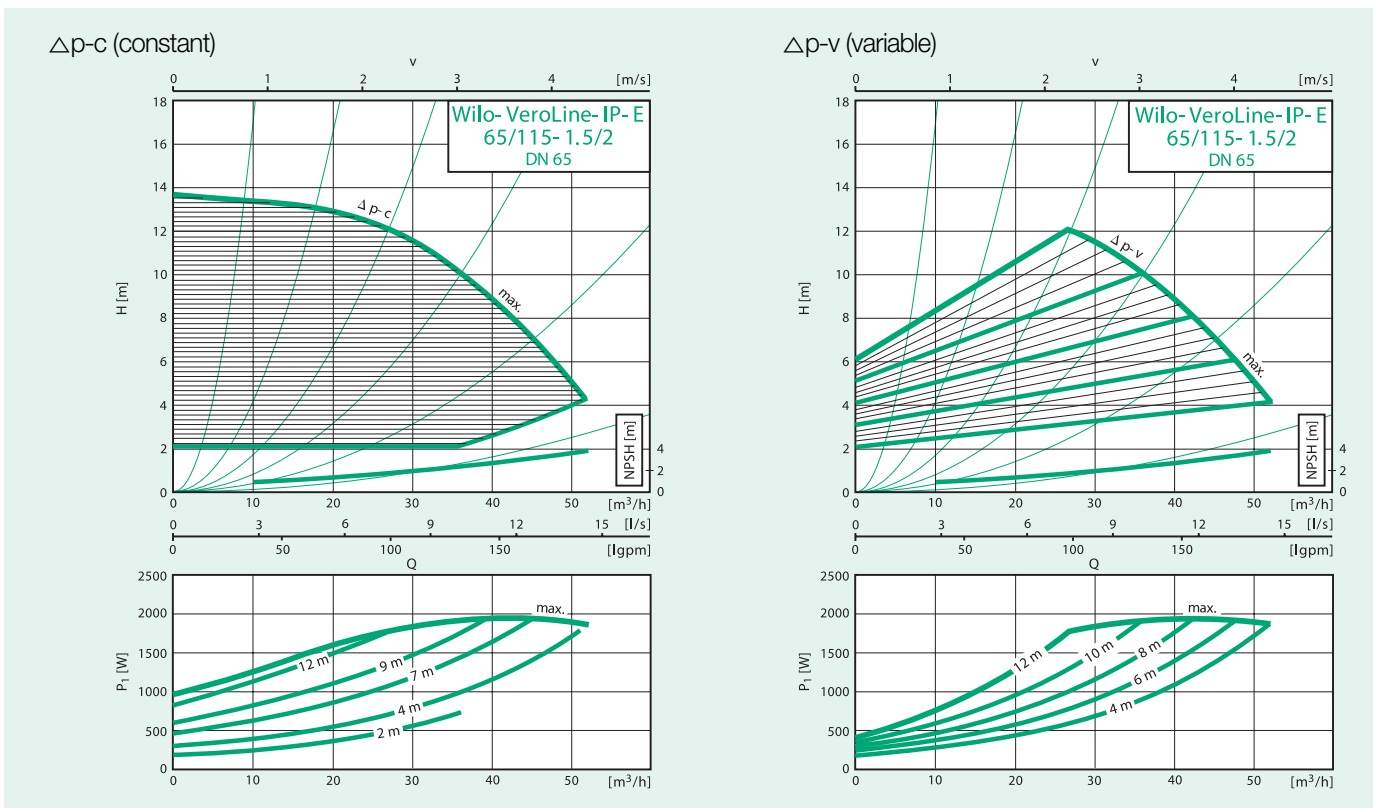

In-Line Pumps

IP-E Series



성능곡선

IP-E 65/130-3/2

$\Delta p-c$ (constant)

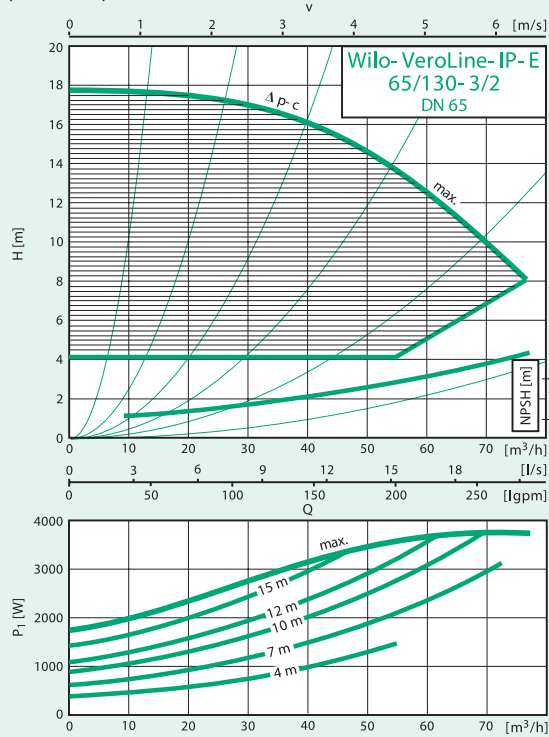

$\Delta p-v$ (variable)

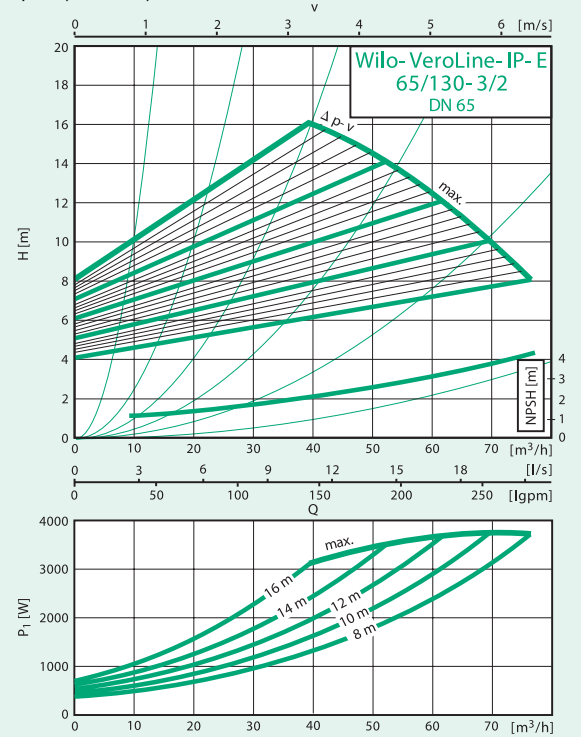

IP-E 65/140-4/2

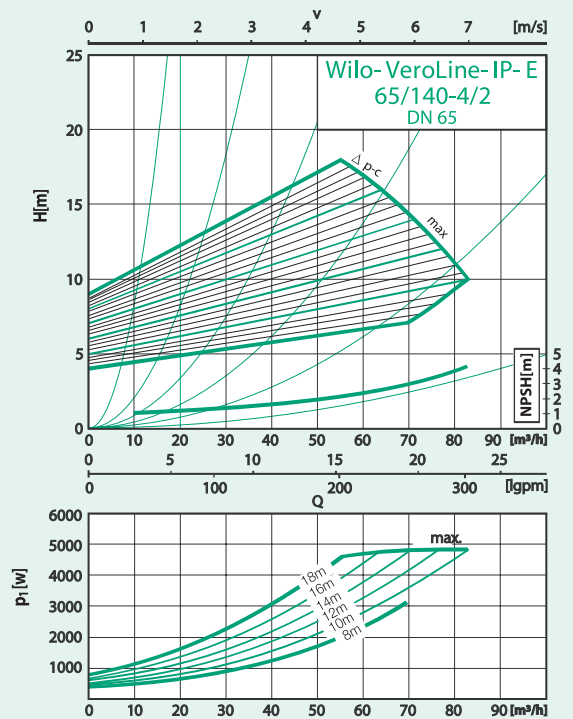
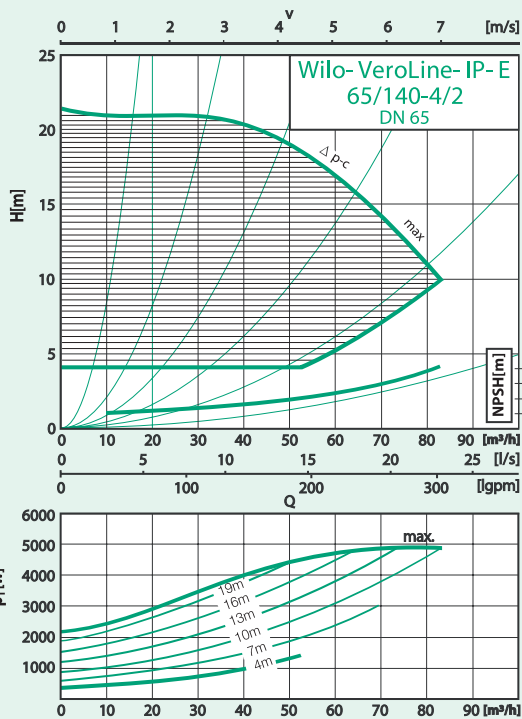

IP-E 80/115-2.2/2

$\Delta p-c$ (constant)

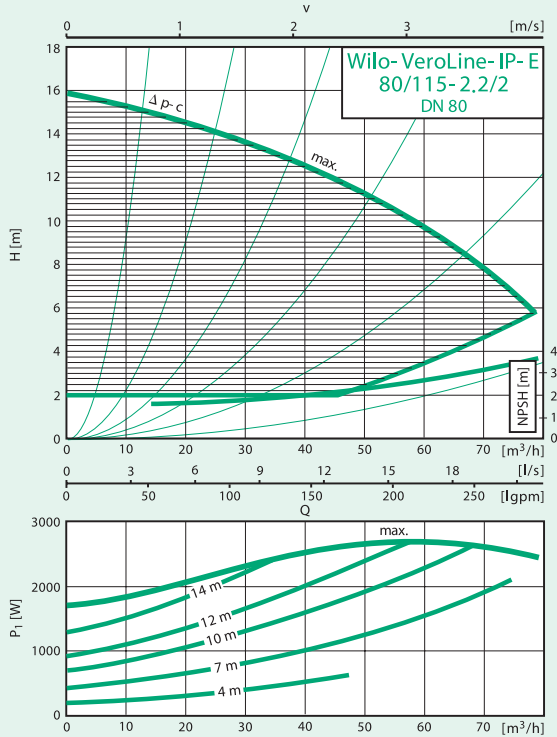

$\Delta p-v$ (variable)

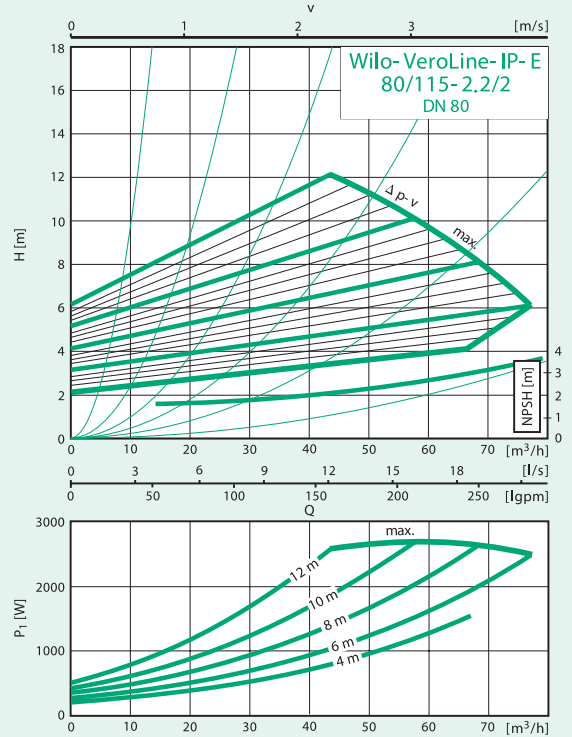

IP-E 80/130-3/2

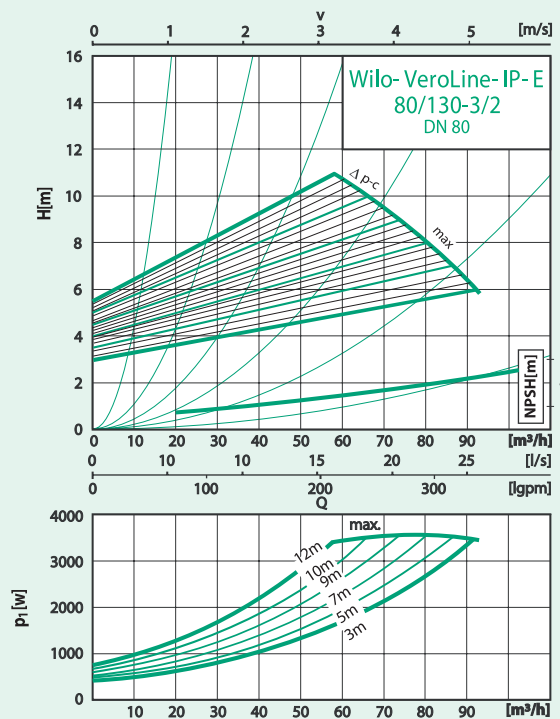
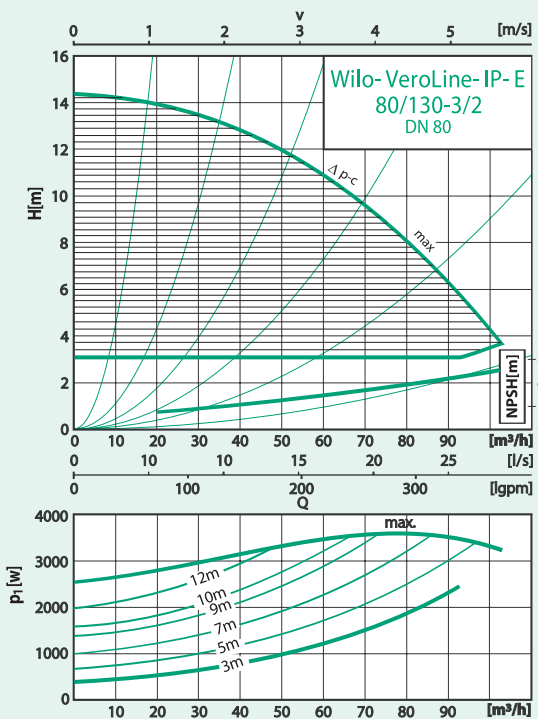

In-Line Pumps

IL- Series



Product Advantages

IP-E 80/140-4/2

$\Delta p-c$ (constant)

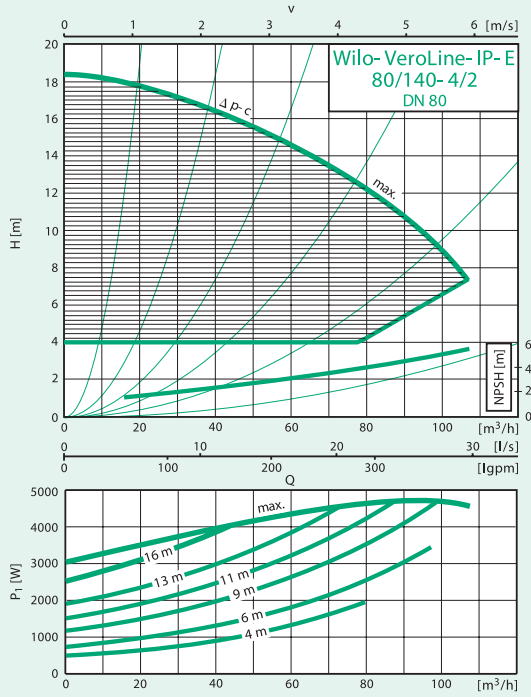

$\Delta p-v$ (variable)

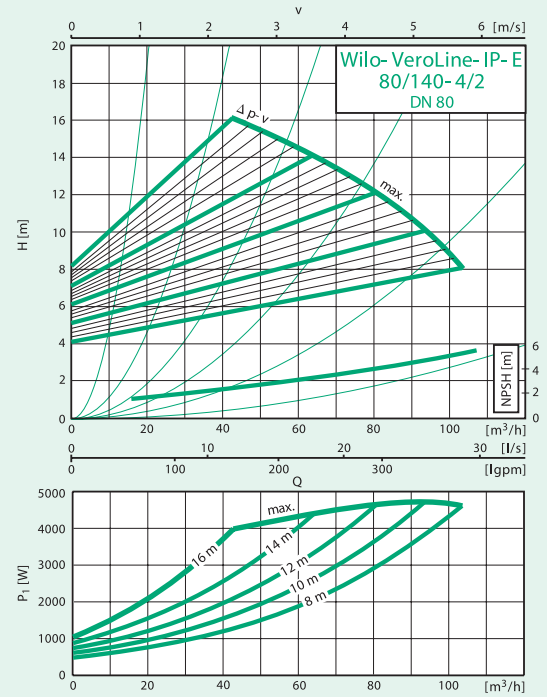

결선도

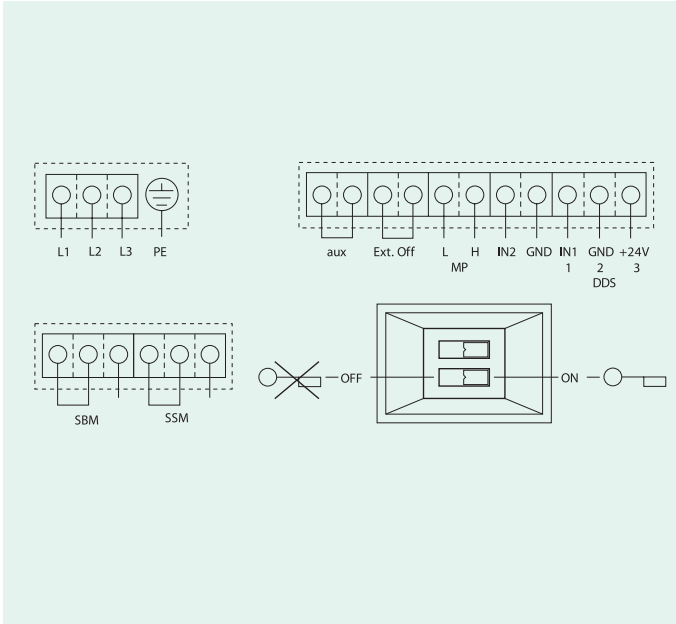

Switch rating of interference contacts for the collective run and Fault signal :

Min. 12 V DC/10 mA, max. 250 V AC/1A

L1, L2, L3, PE	Mains connection 3~400 V/50 Hz
SSM	Potential-free collective fault signal (NC contact in accordance with VDI 3814)
SBM	Potential-free collective run signal (NC contact in accordance with VDI 3814)
off	Control input "Overriding OFF" (24V)
PLR	Serial digital BA interface
DPM	Interface for the connection of a slave pump for fully-integrated twin-head pump management
3	+24 V(Output) for ext. consumer/sensor
2	Earth(⊥)
1	0-10 V (Input) corresponds to 40%-100% for the nominal speed

Changeover key activated/ deactivated.

모터 DATA

Model	Nominal power P ₂ max. [kW]	Speed n [rpm]	Power consumption P ₁ [W]	Current I max [A]
IP-E 32/160-1,1/2	1,10	1200-2840	1340	3,6
IP-E 40/115-0,55/2	0,55	1150-2800	810	1,8
IP-E 40/150-3/2	3,00	1200-2890	3570	7,5
IP-E 40/160-4/2	4,00	1200-2900	4710	9,6
IP-E 50/115-0,75/2	0,75	1150-2850	1120	2,9
IP-E 50/140-3/2	3,00	1200-2890	3530	7,8
IP-E 50/150-4/2	4,00	1200-2900	4880	10,1
IP-E 65/115-1,5/2	1,50	1080-2860	1910	4,8
IP-E 65/130-3/2	3,00	1200-2890	3670	7,9
IP-E 65/140-4/2	4,00	1200-2900	4950	10,1
IP-E 80/115-2,2/2	2,20	1030-2880	2620	6,8
IP-E 80/130-3/2	3,00	1200-2890	3510	7,7
IP-E 80/140-4/2	4,00	1200-2900	4930	10,2

Three-phase motor (DM), 2-Pole-3~400V, 50Hz / 3~380V,60Hz

In-Line Pumps

DP-E Series



외형도 및 치수

외형도

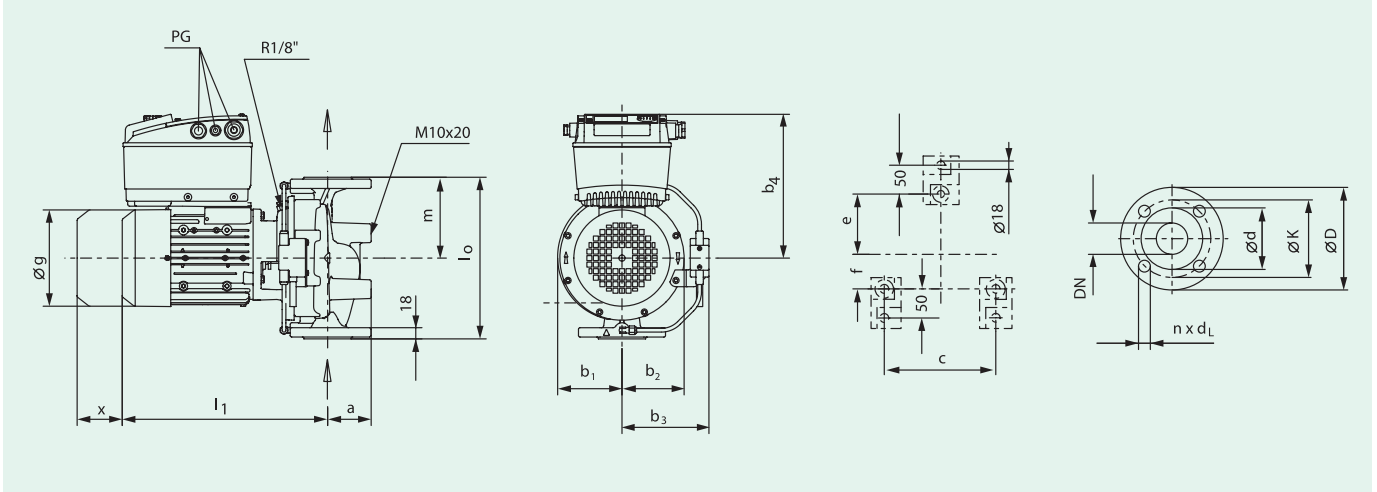

Note :

Housing with feet for installation in foundation and holes M10.
Support brackets on request

외형치수

Model	Pipe connection/ nominal diameter	Pump dimensions												PG	Weight, approx.		
		-	l ₀	a	b ₁	b ₂	b ₃	b ₄	c	e	f	g	l ₁			X	-
		DN	[mm]													-	[kg]
IP-E 32/160-1,1/2	32	260	70	106	101	142	237	90	40	50	163	348	150			28	
IP-E 40/115-0,55/2	40	250	75	90	80	114	228	90	40	50	145	310	150			22	
IP-E 40/150-3/2	40	320	75	121	113	142	267	90	40	50	203	327	150			39	
IP-E 40/160-4/2	40	320	75	121	113	142	279	90	40	50	203	413	150	1xM25		45	
IP-E 50/115-0,75/2	50	280	83	101	91	126	237	90	40	50	163	353	150	1xM20		25	
IP-E 50/140-3/2	50	340	86	131	116	143	267	104	40	50	227	409	150	1xM16		42	
IP-E 50/150-4/2	50	340	86	131	116	143	279	104	40	50	227	413	150	2xM12		48	
IP-E 65/115-1,5/2	65	340	93	118	10	137	255	104	40	50	180	389	150			34	
IP-E 65/130-3/2	65	340	93	138	119	163	267	135	40	55	203	409	150			44	
IP-E 65/140-4/2	65	340	93	138	119	163	279	135	40	55	203	413	150			50	
IP-E 80/115-2,2/2	80	360	100	135	110	137	255	135	40	55	180	391	150			37	
IP-E 80/130-3/2	80	360	105	153	125	143	267	135	40	55	227	409	150			54	
IP-E 80/140-4/2	80	360	105	135	125	143	279	135	40	55	227	413	150			54	

플랜지 규격

Model	Pipe connection/ nominal diameter	Flange dimensions, pumps-to EN 1092-2 PN16				
		-	D	d	k	n x d _L
		DN	[mm]			[no. x mm]
IP-E 32...	32	140	78	100	4 x 19	
IP-E 40...	40	150	88	110	4 x 19	
IP-E 50...	50	165	102	125	4 x 19	
IP-E 65...	65	185	122	145	4 x 19	
IP-E 80...	80	200	138	160	8 x 19	

n=No. of bolt holes

DP-E 32/160-1.1/2

Δp -c (constant) individual operation

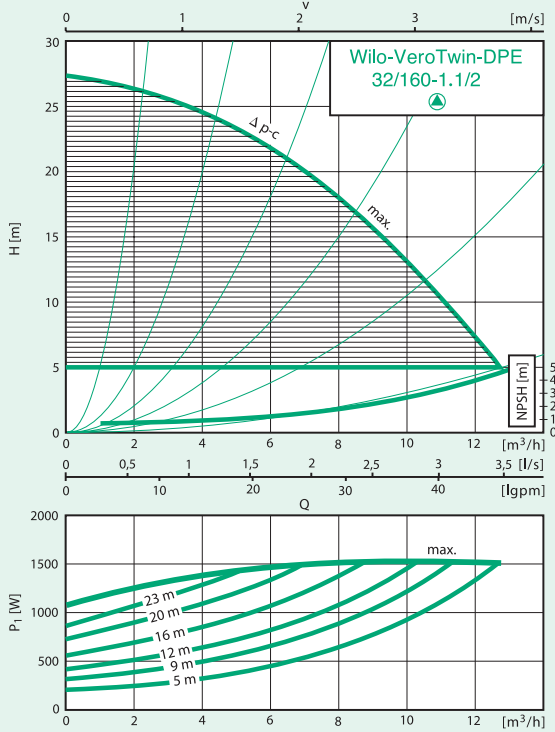

Δp -v (variable) individual operation

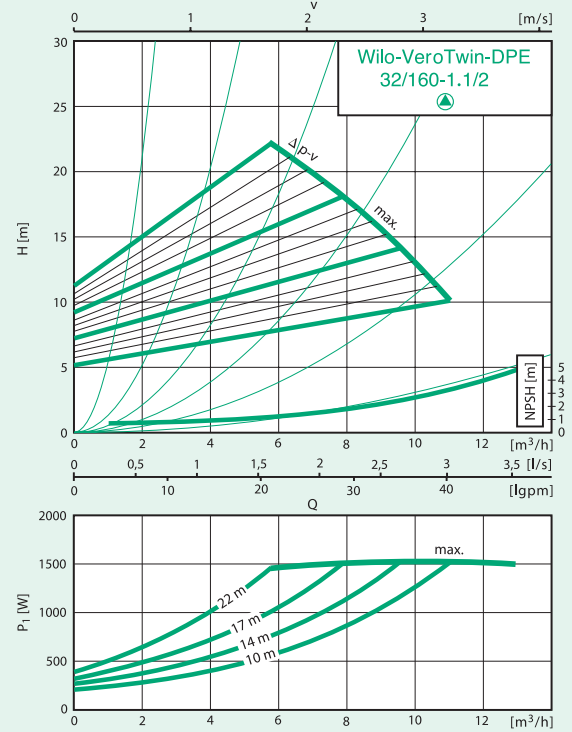

DP-E 32/160-1.1/2

Δp -c (constant) parallel operation

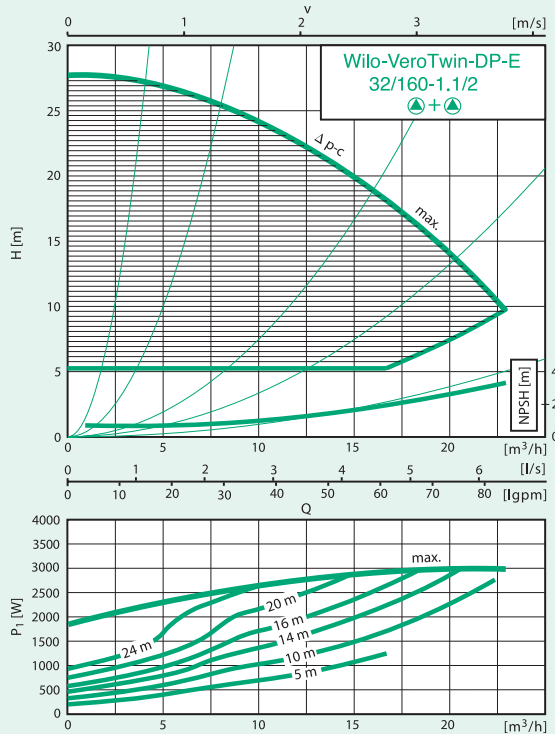

Δp -c (variable) parallel operation

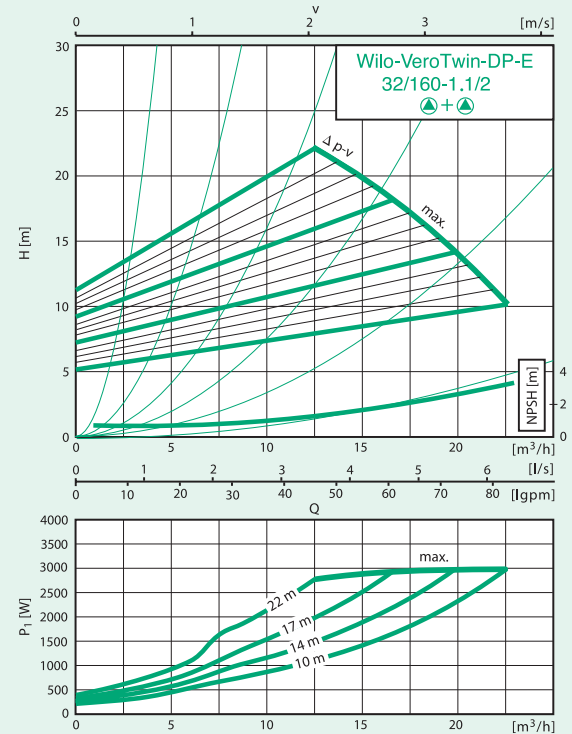

In-Line Pumps

DP-E Series



성능곡선

DP-E 40/115-0.55/2

$\Delta p-c$ (constant) individual operation

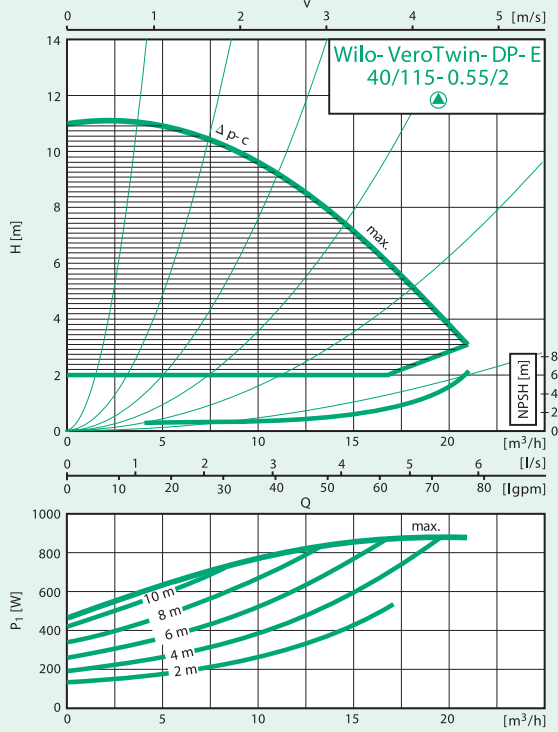

$\Delta p-v$ (variable) individual operation

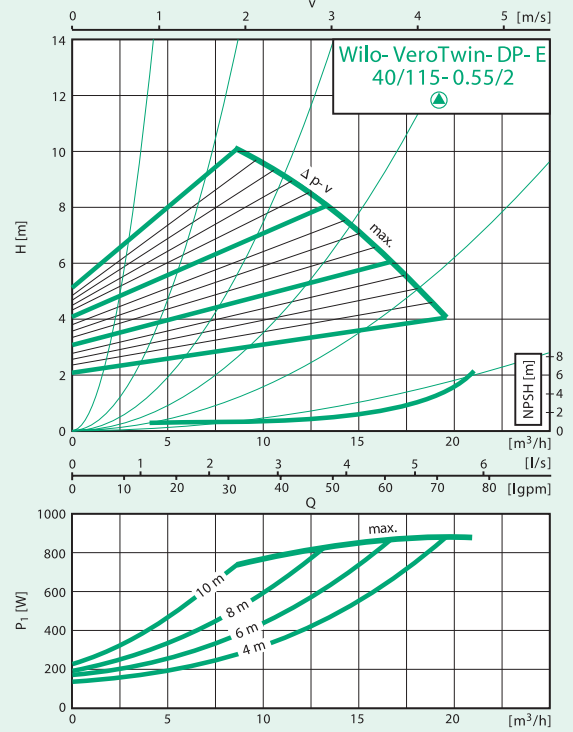

DP-E 40/115-0.55/2

$\Delta p-c$ (constant) parallel operation

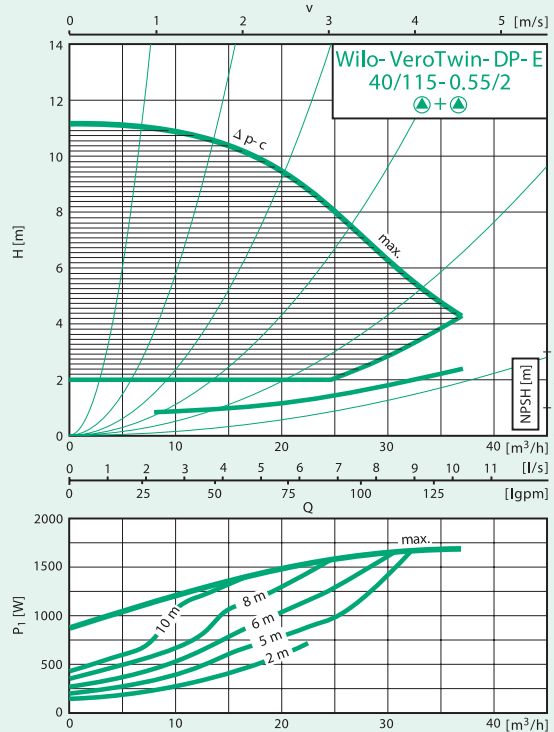

$\Delta p-c$ (variable) parallel operation

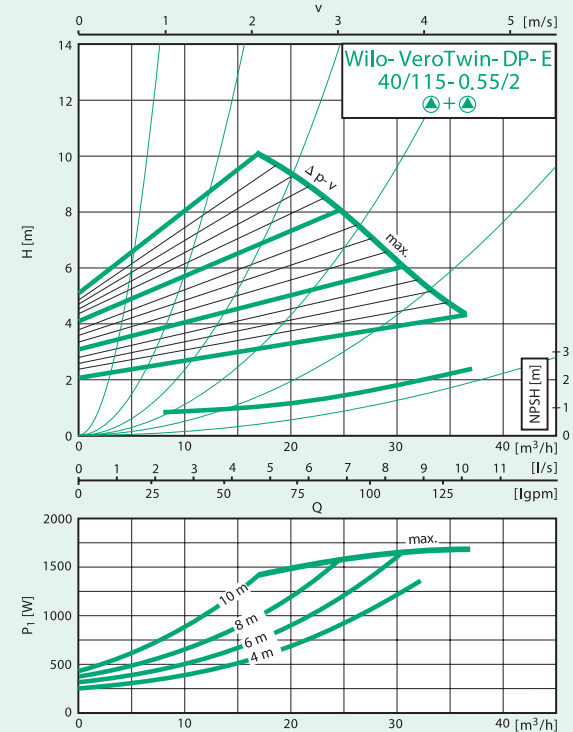

DP-E 40/150-3/2

$\Delta p-c$ (constant) individual operation

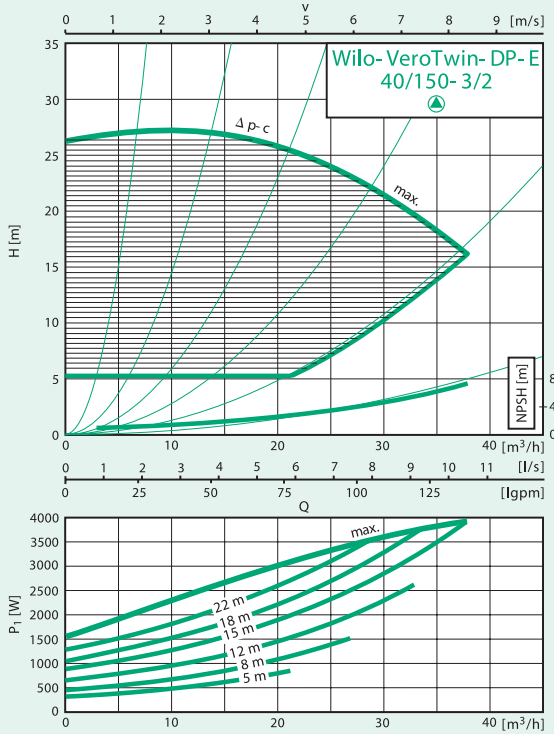

$\Delta p-v$ (variable) individual operation

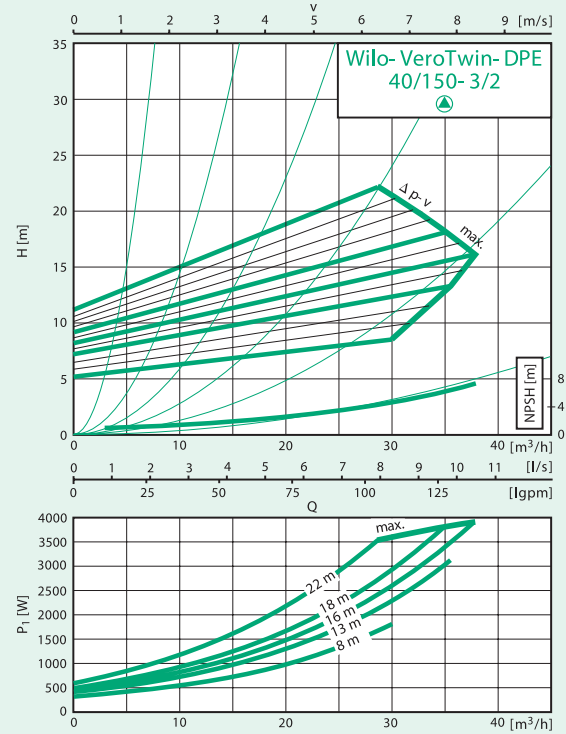

DP-E 40/150-3/2

$\Delta p-c$ (constant) parallel operation

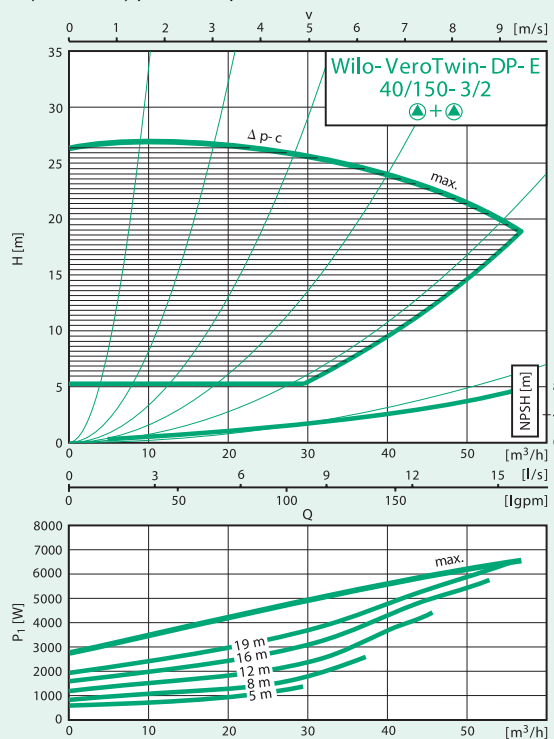

$\Delta p-c$ (variable) parallel operation

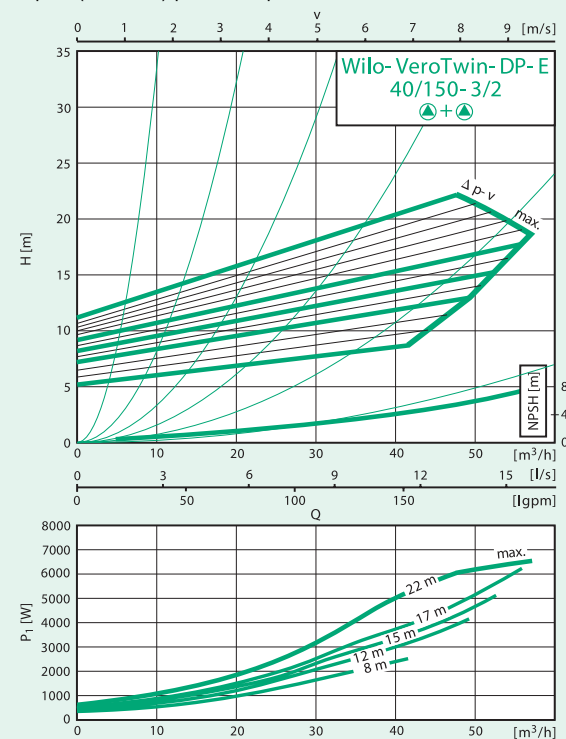

In-Line Pumps

DP-E Series



성능곡선

DP-E 40/160-4/2

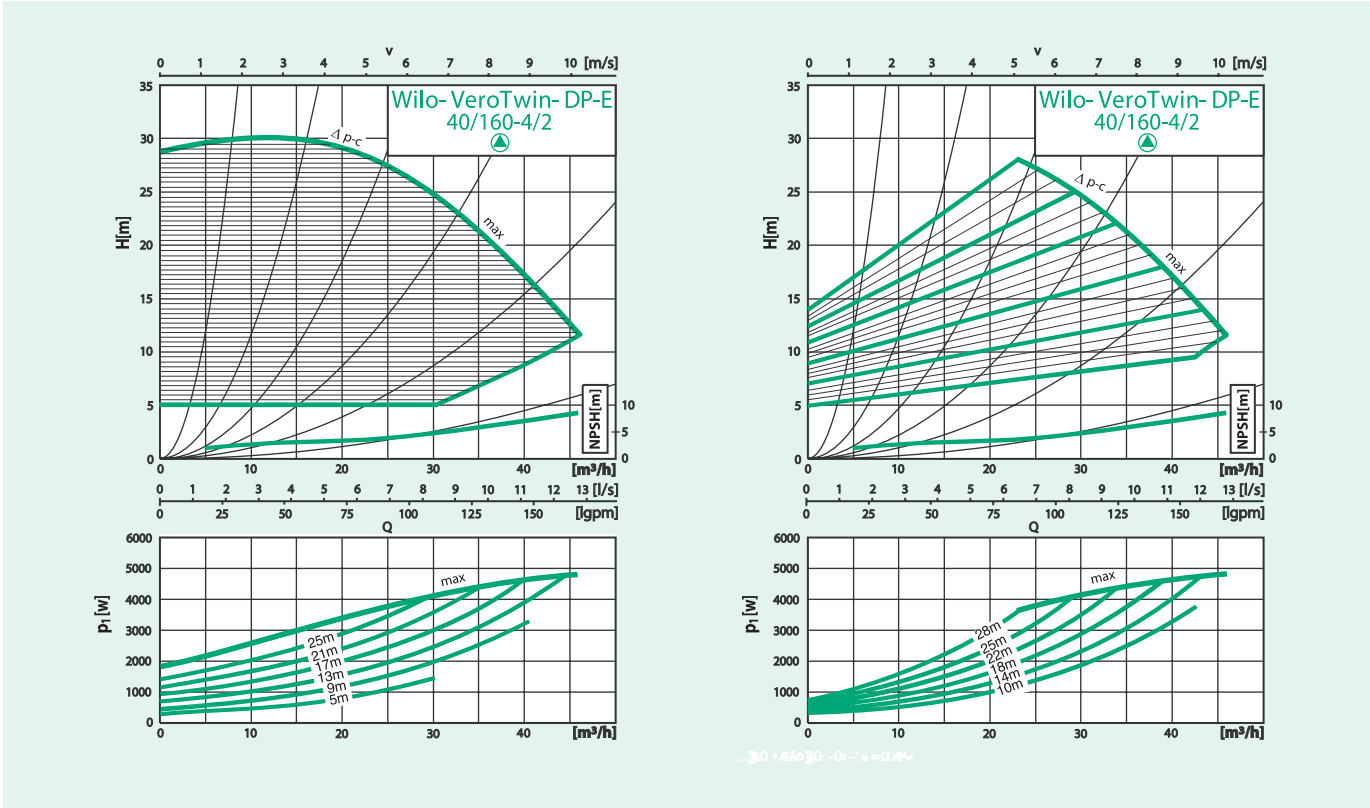

DP-E 40/160-4/2

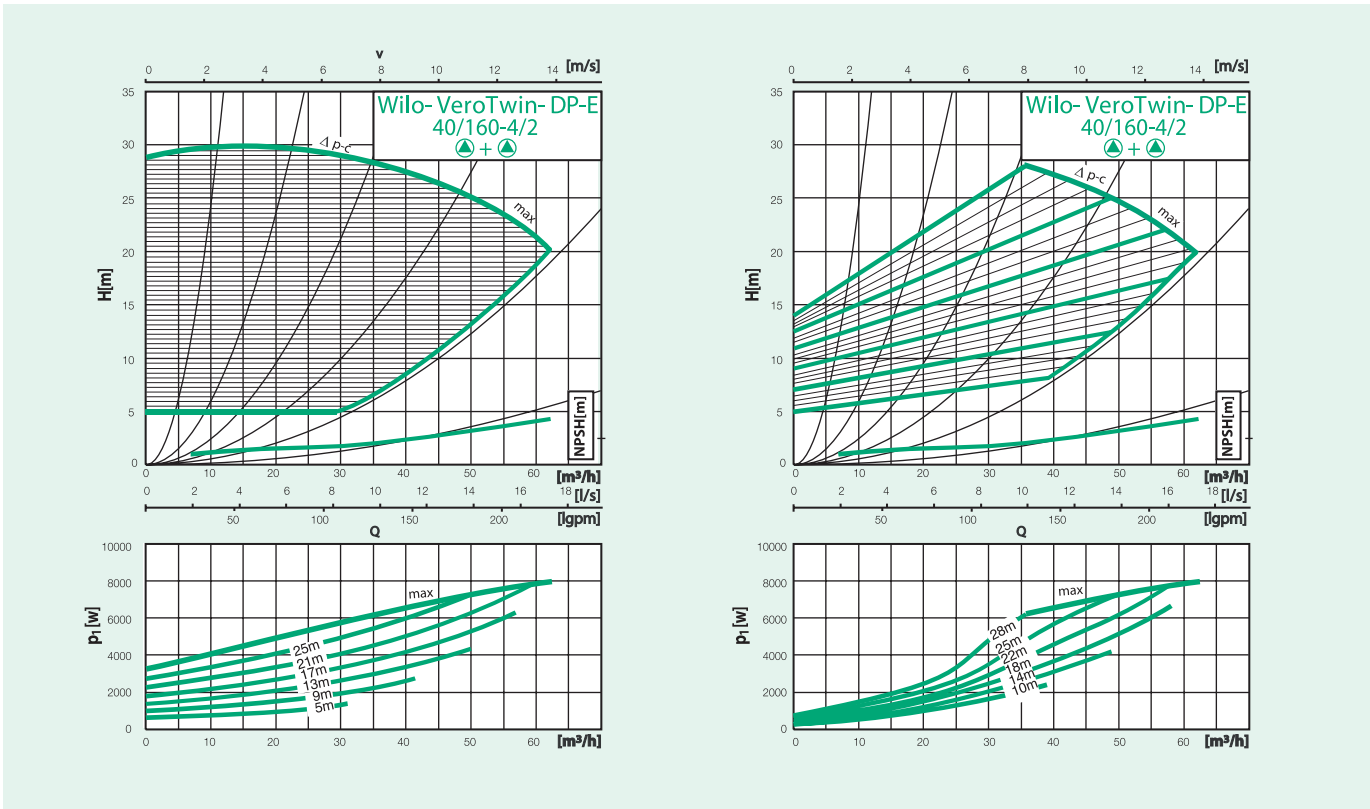

DP-E 50/115-0.75/2

Δp -c (constant) individual operation

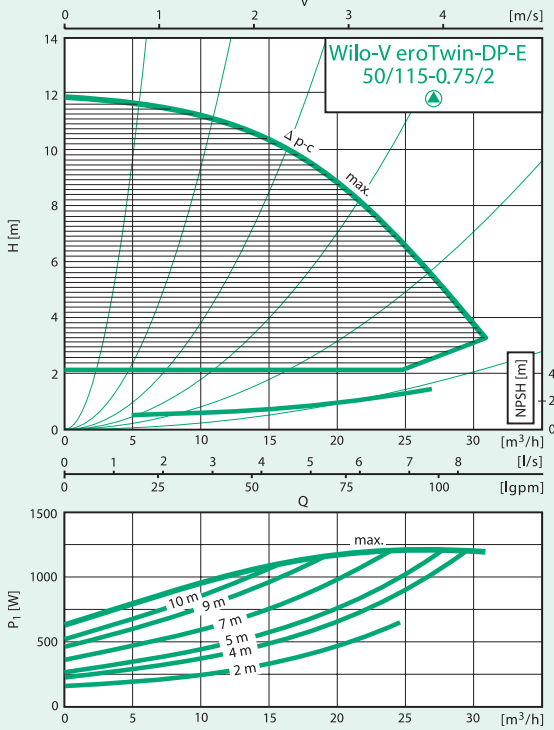

Δp -v (variable) individual operation

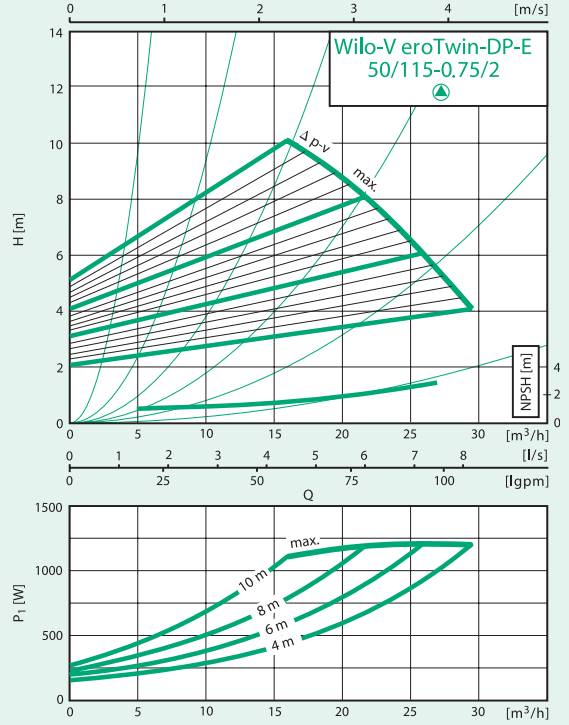

DP-E 50/115-0.75/2

Δp -c (constant) parallel operation

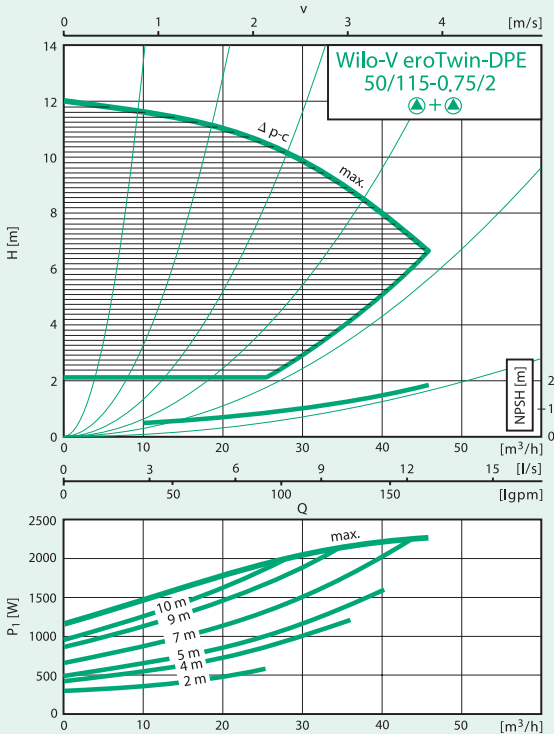

Δp -c (variable) parallel operation

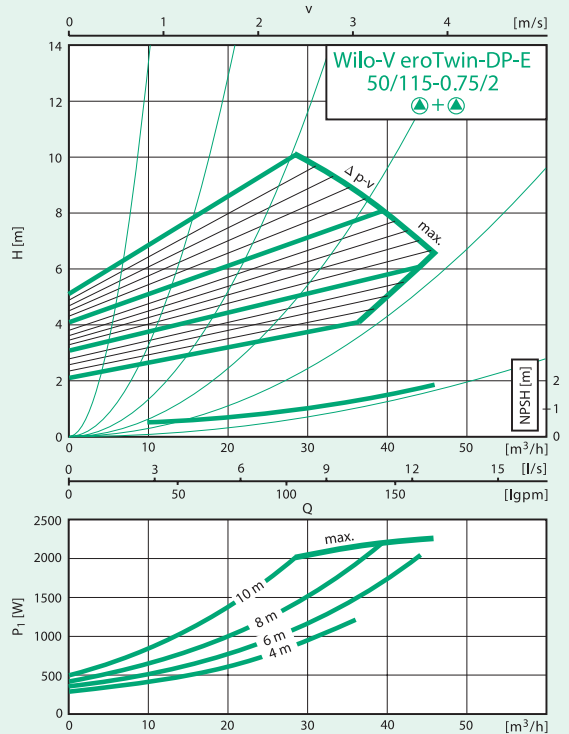

In-Line Pumps

DP-E Series



성능곡선

DP-E 50/140-3/2

Δp -c (constant) individual operation

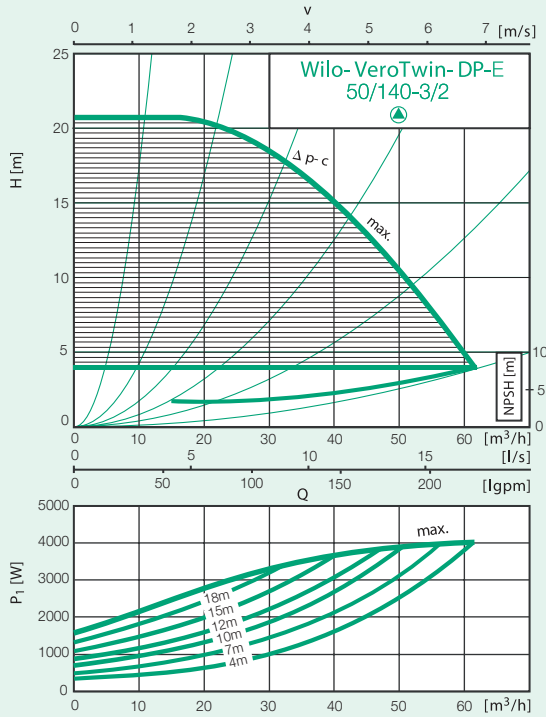

Δp -v (variable) individual operation

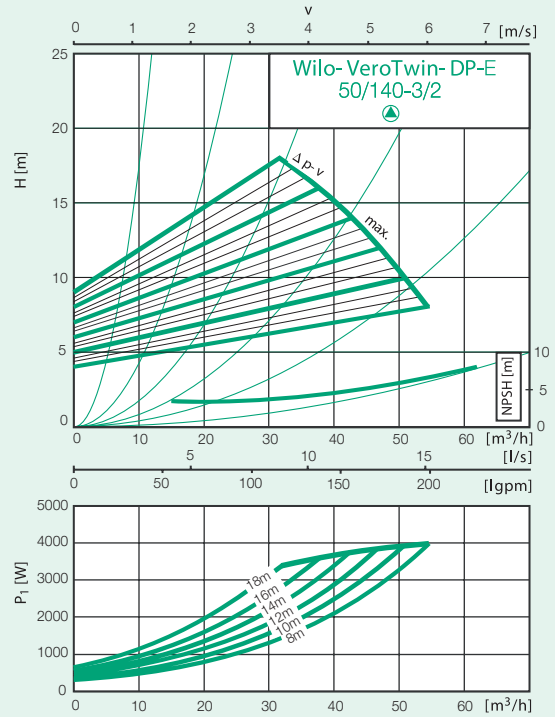

DP-E 50/140-3/2

Δp -c (constant) parallel operation

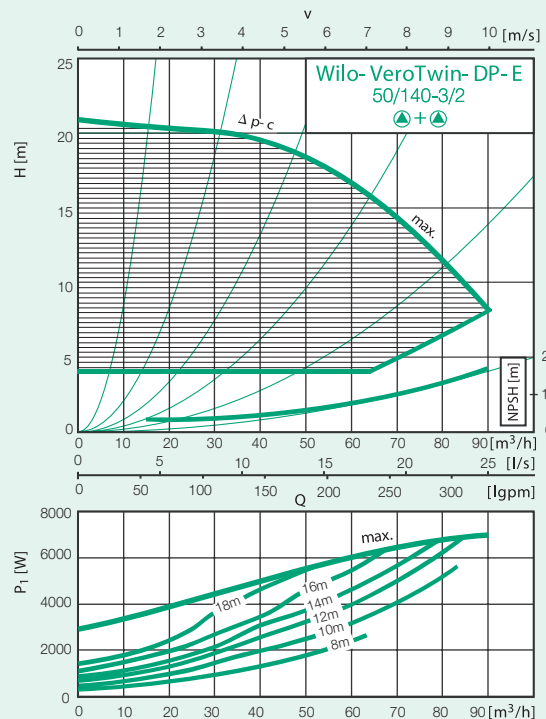

Δp -c (variable) parallel operation

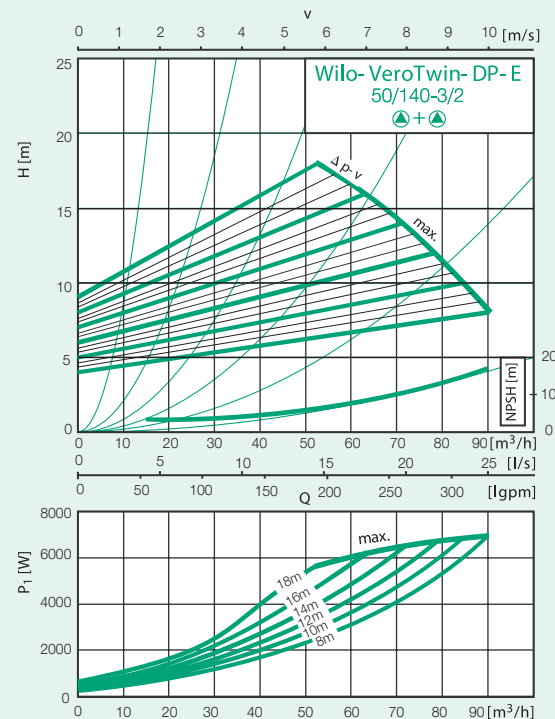

DP-E 50/150-4/2

$\Delta p-c$ (constant) individual operation

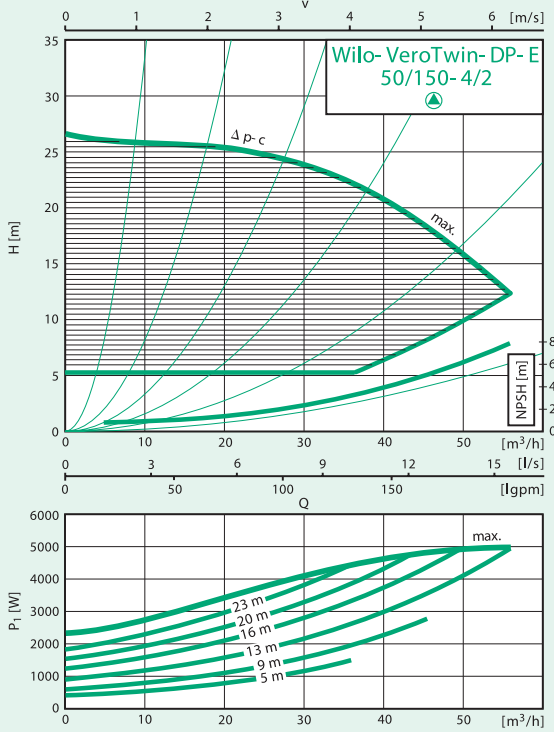

$\Delta p-v$ (variable) individual operation

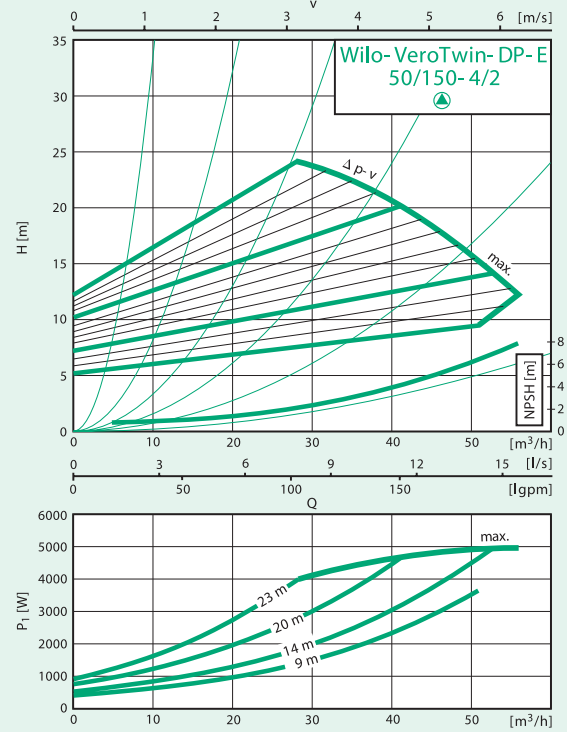

DP-E 50/150-4/2

$\Delta p-c$ (constant) parallel operation

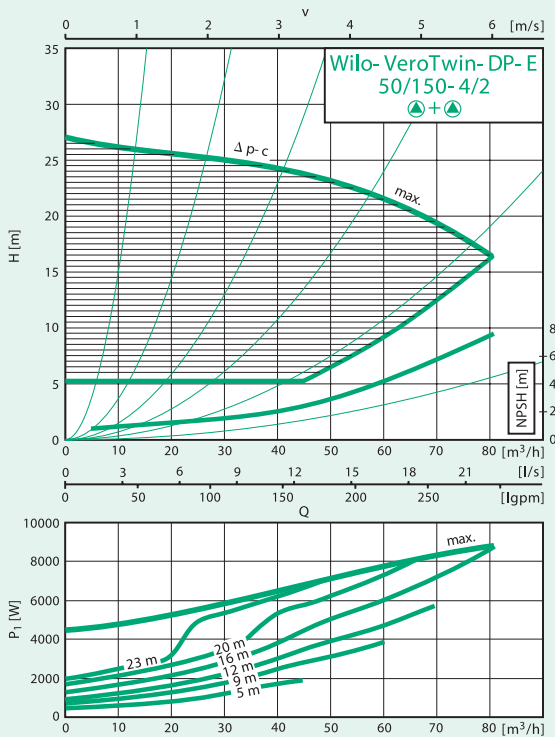

$\Delta p-c$ (variable) parallel operation

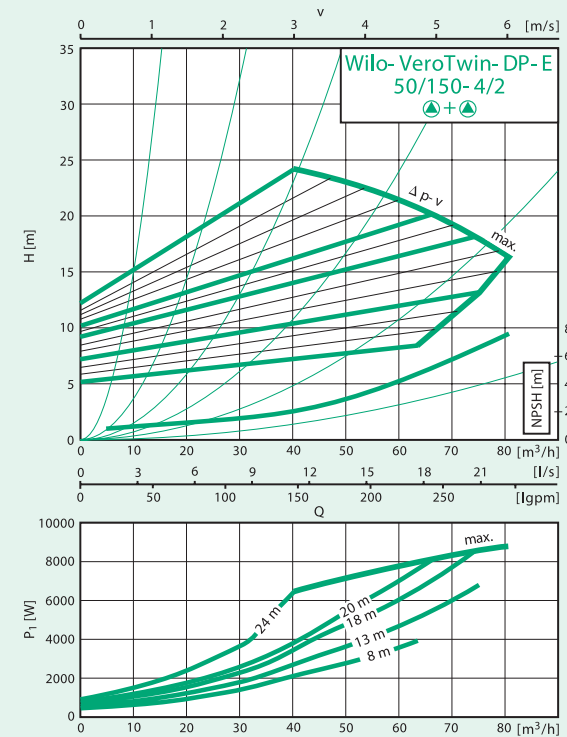

In-Line Pumps

DP-E Series



성능곡선

DP-E 65/115-1.5/2

$\Delta p-c$ (constant) individual operation

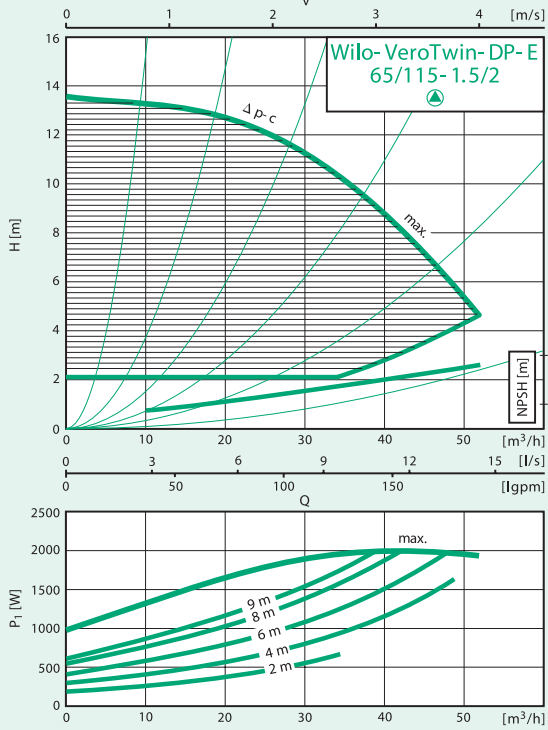

$\Delta p-v$ (variable) individual operation

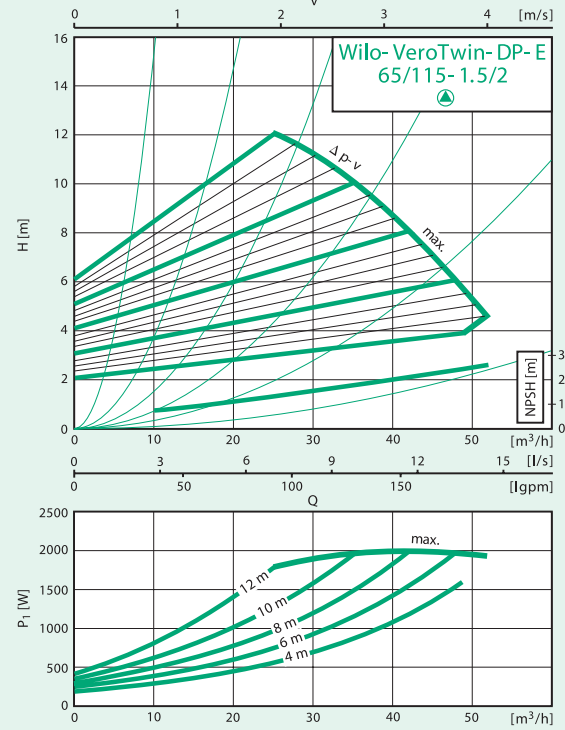

DP-E 65/115-1.5/2

$\Delta p-c$ (constant) parallel operation

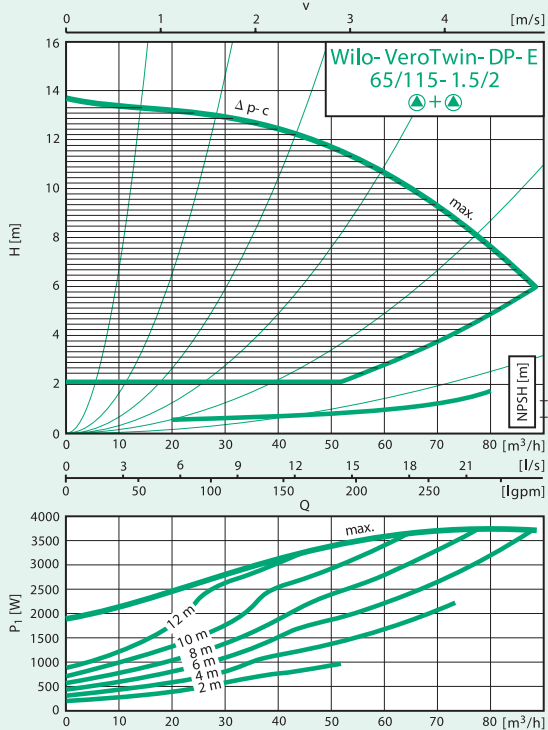

$\Delta p-c$ (variable) parallel operation

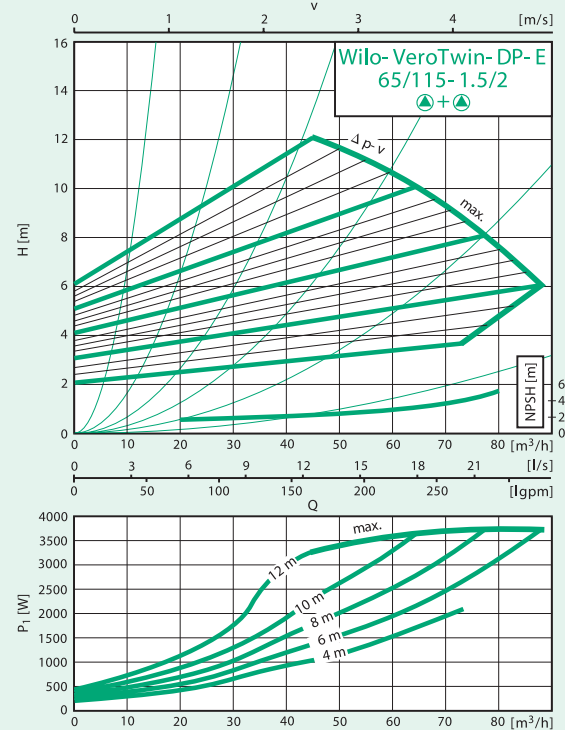

DP-E 65/130-3/2

$\Delta p-c$ (constant) individual operation

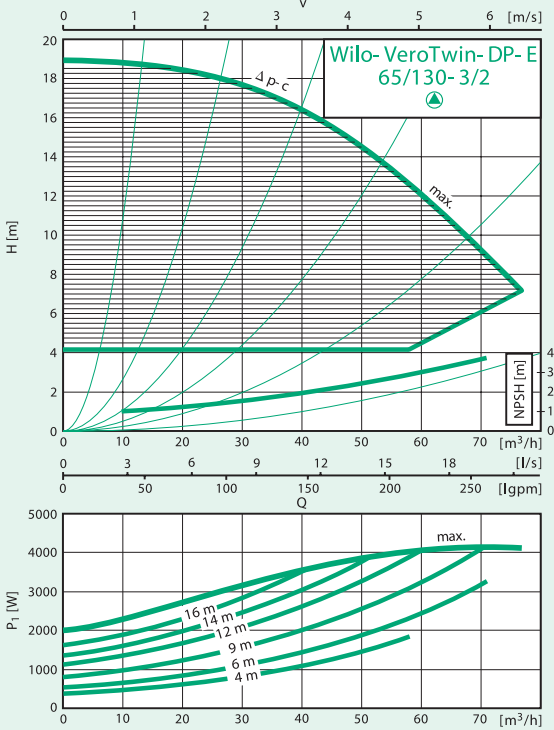

$\Delta p-v$ (variable) individual operation

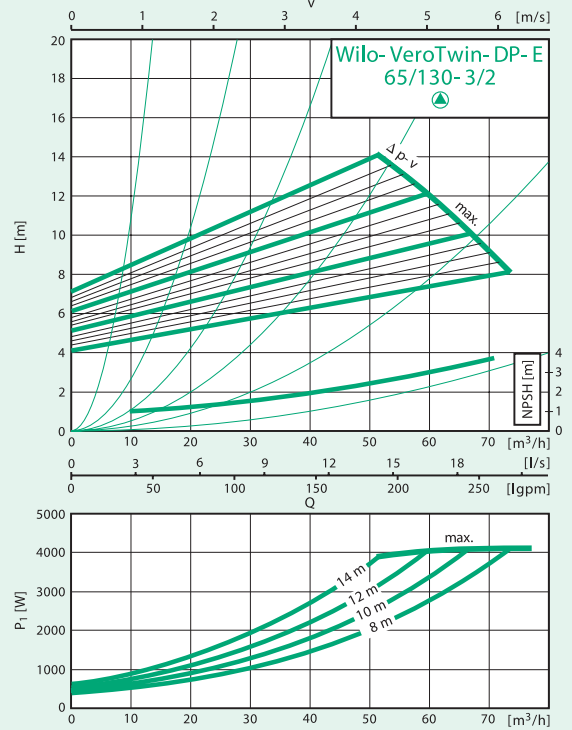

DP-E 65/130-3/2

$\Delta p-c$ (constant) parallel operation

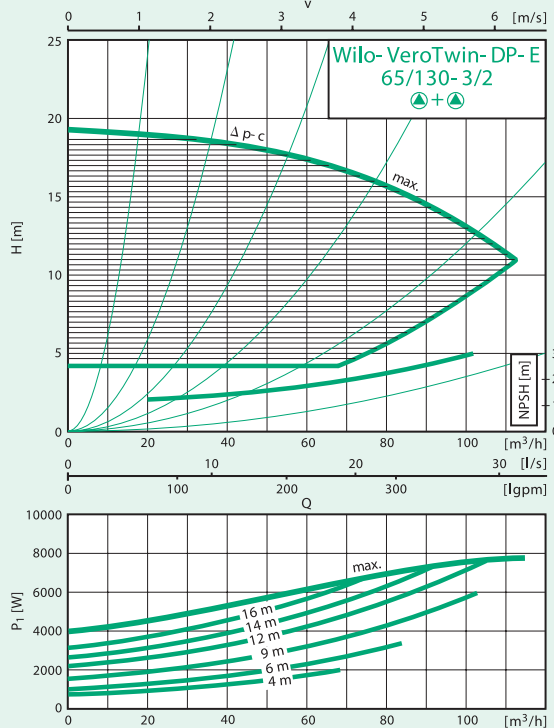

$\Delta p-c$ (variable) parallel operation

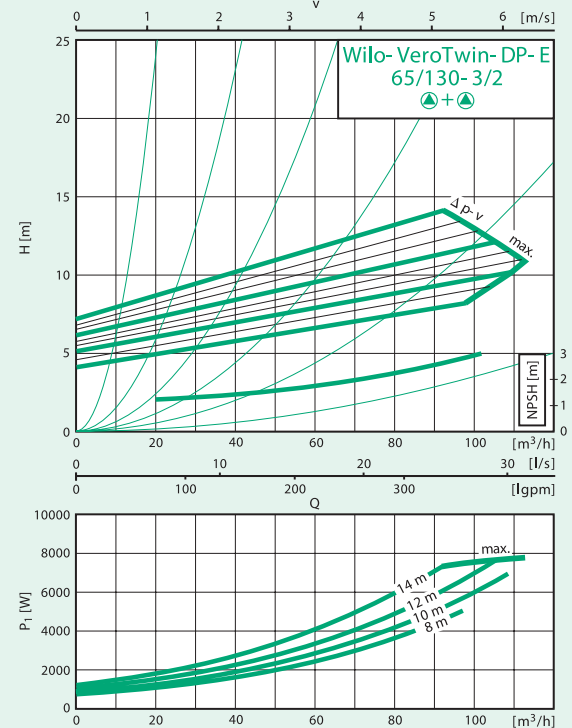

In-Line Pumps

DP-E Series



성능곡선

DP-E 65/140-4/2

Δp -c (constant) individual operation

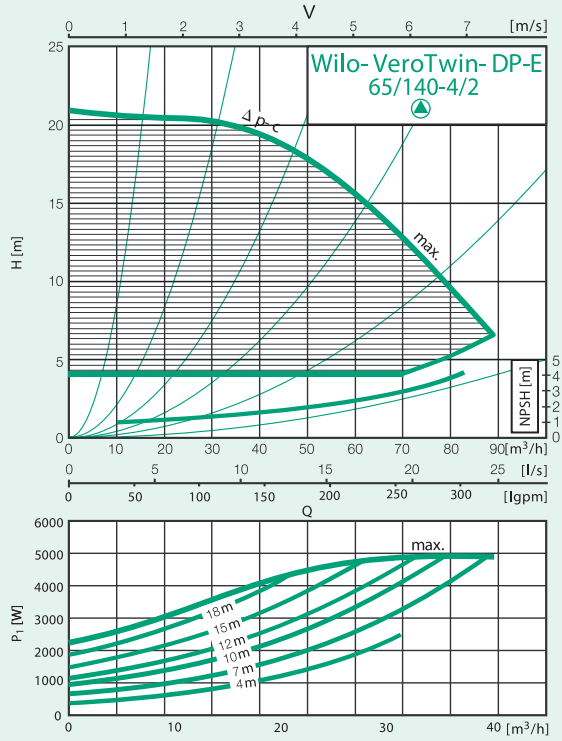

Δp -v (variable) individual operation

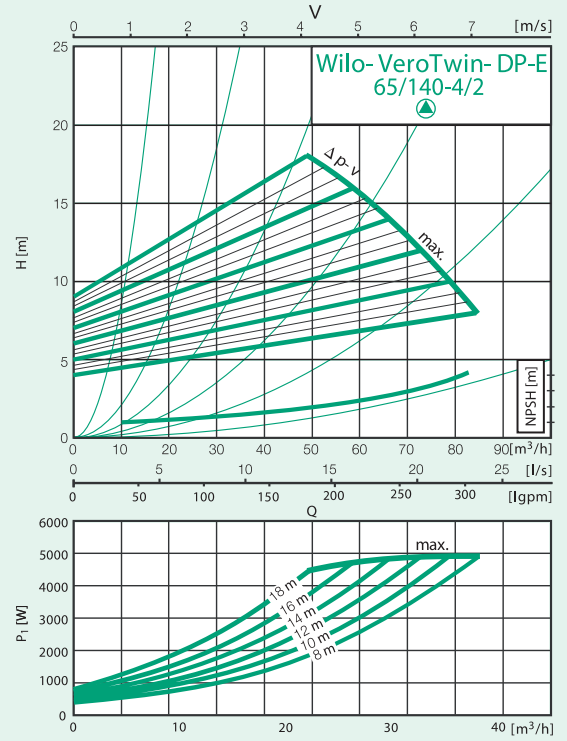

DP-E 65/140-4/2

Δp -c (constant) parallel operation

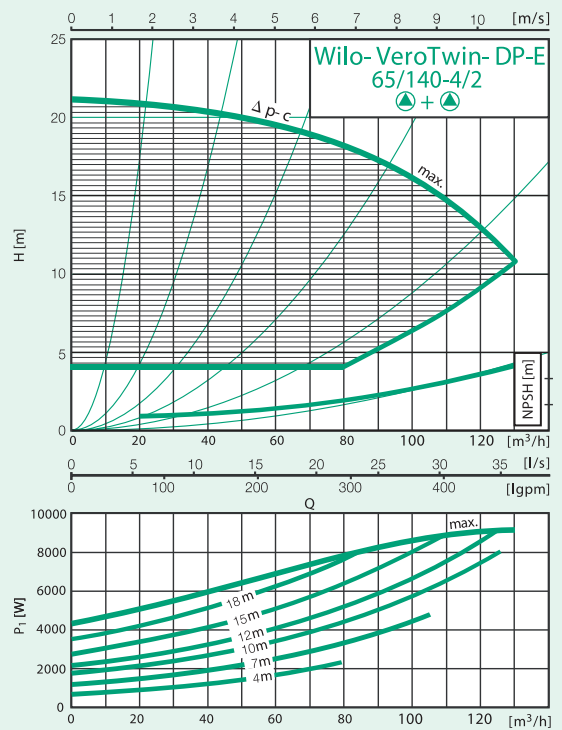

Δp -c (variable) parallel operation

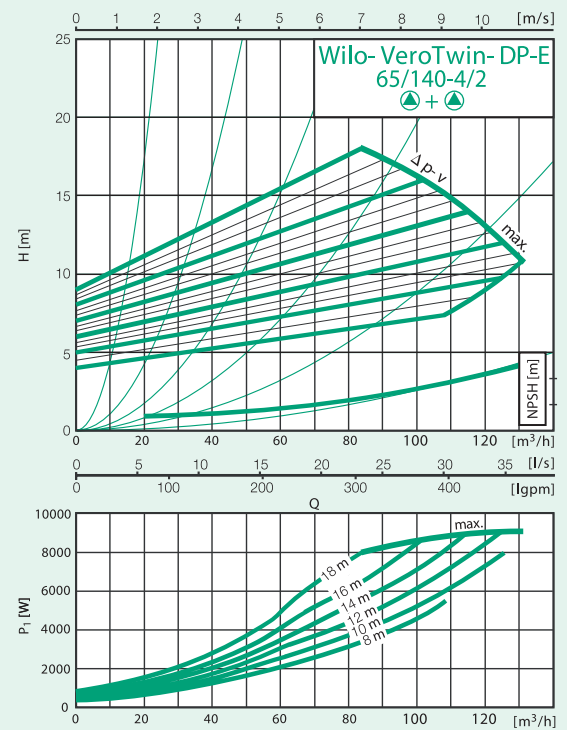

DP-E 80/115-2.2/2

$\Delta p-c$ (constant) individual operation

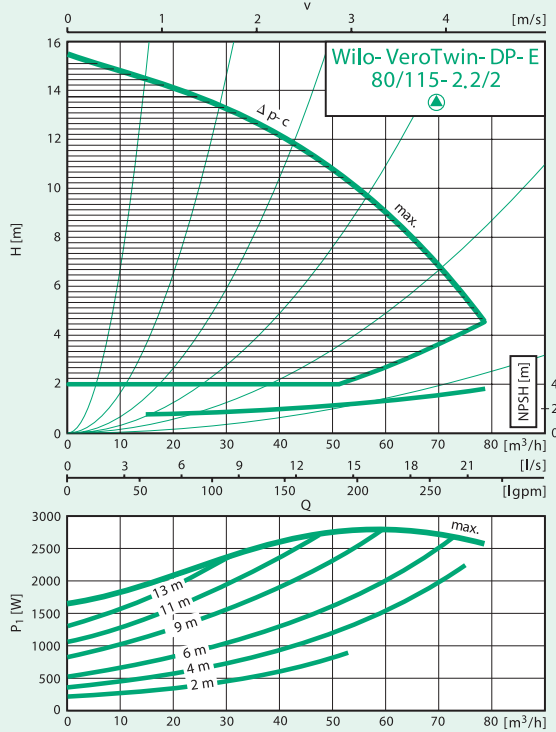

$\Delta p-v$ (variable) individual operation

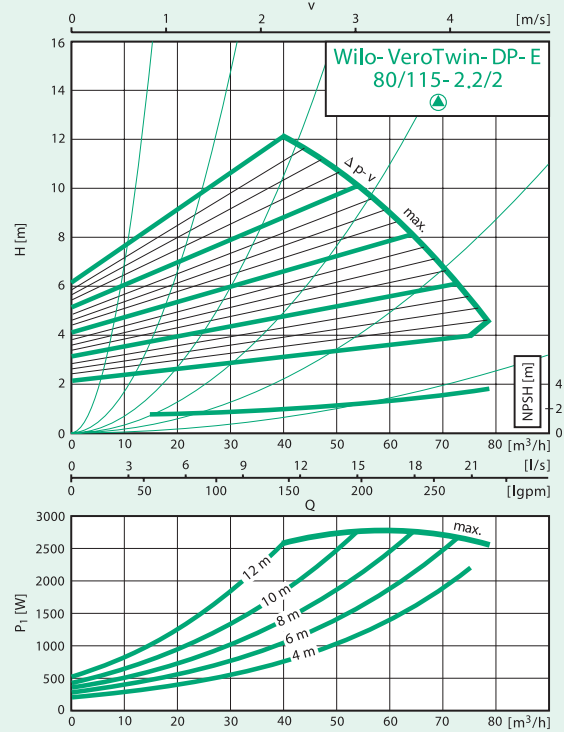

DP-E 80/115-2.2/2

$\Delta p-c$ (constant) parallel operation

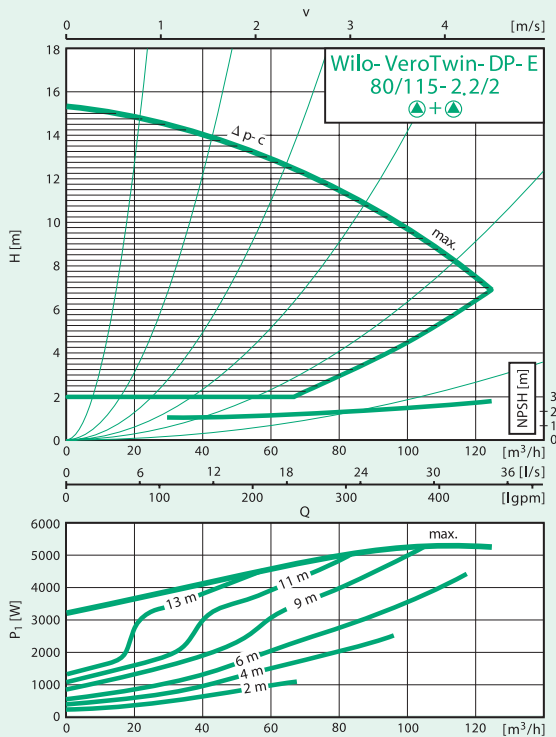

$\Delta p-c$ (variable) parallel operation

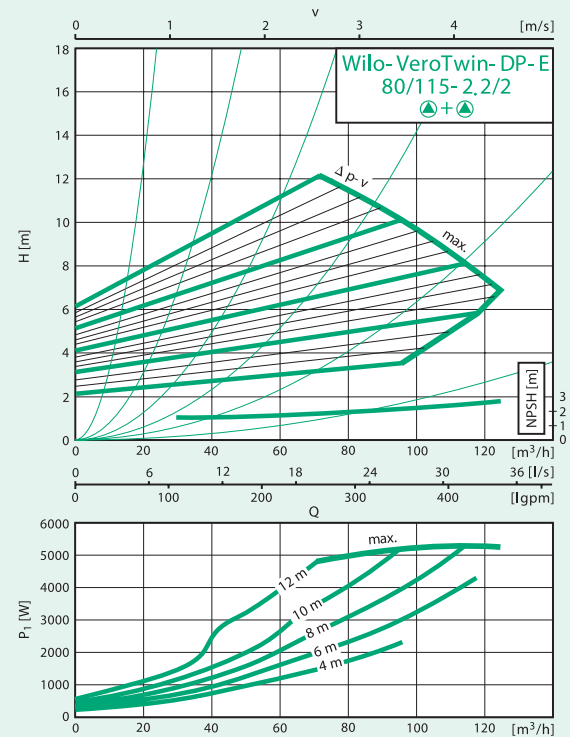

In-Line Pumps

DP-E Series



성능곡선

DP-E 80/130-3/2

Δp -c (constant) individual operation

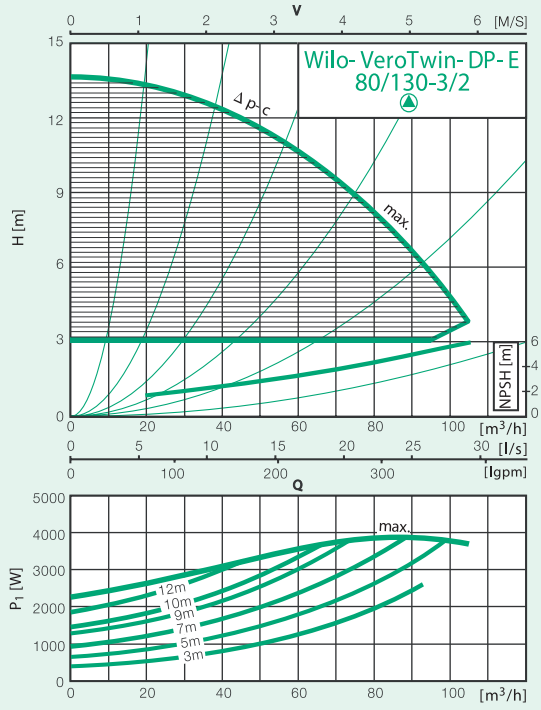

Δp -v (variable) individual operation

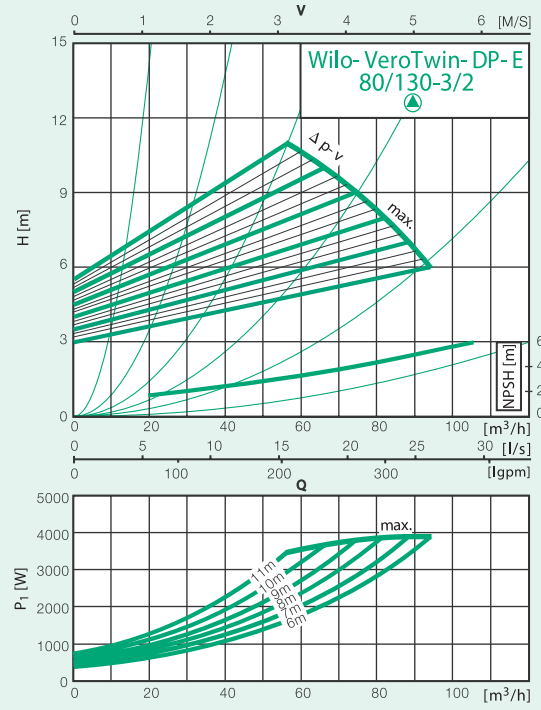

DP-E 80/130-3/2

Δp -c (constant) parallel operation

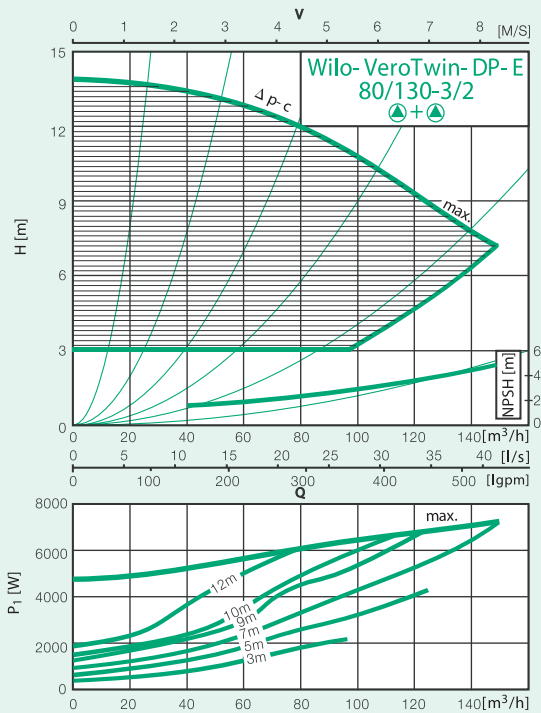

Δp -c (variable) parallel operation

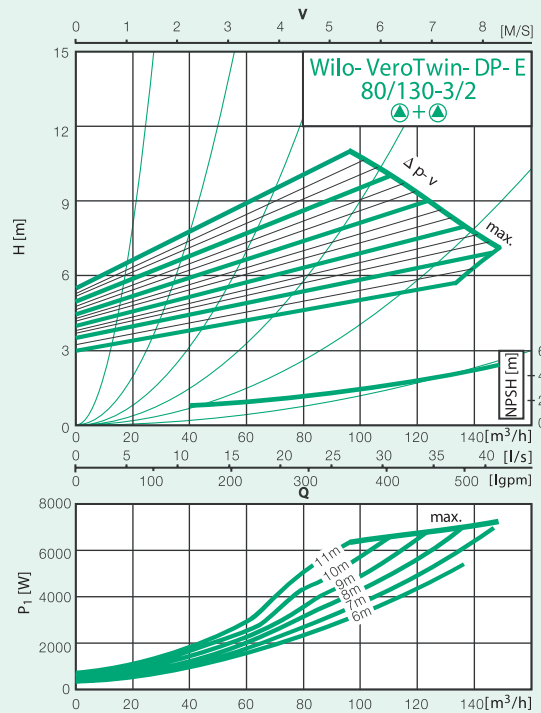

DP-E 80/140-4/2

Δp -c (constant) individual operation

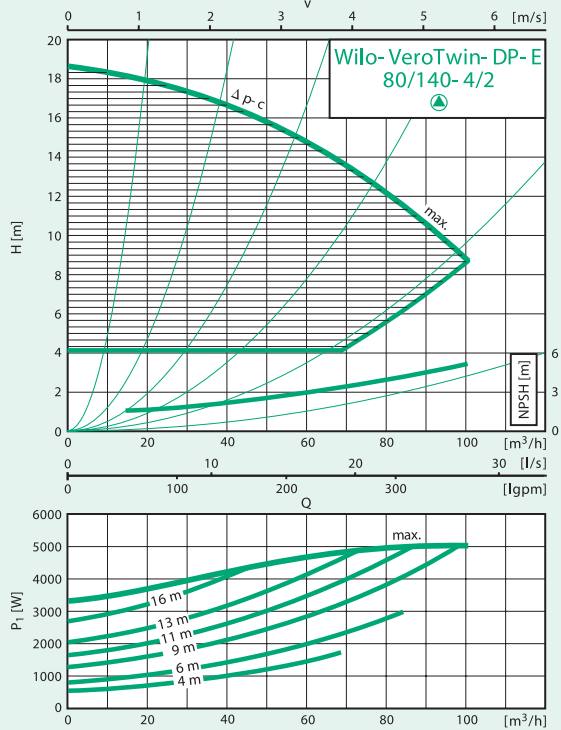

Δp -v (variable) individual operation

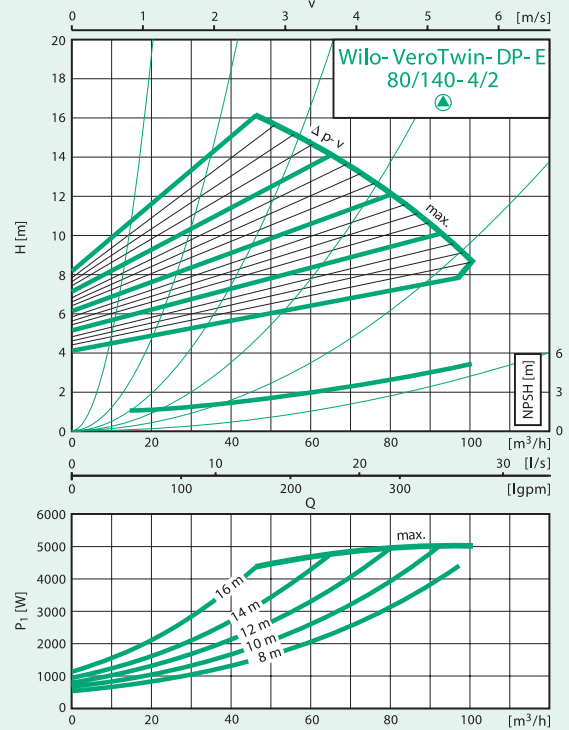

DP-E 80/140-4/2

Δp -c (constant) parallel operation

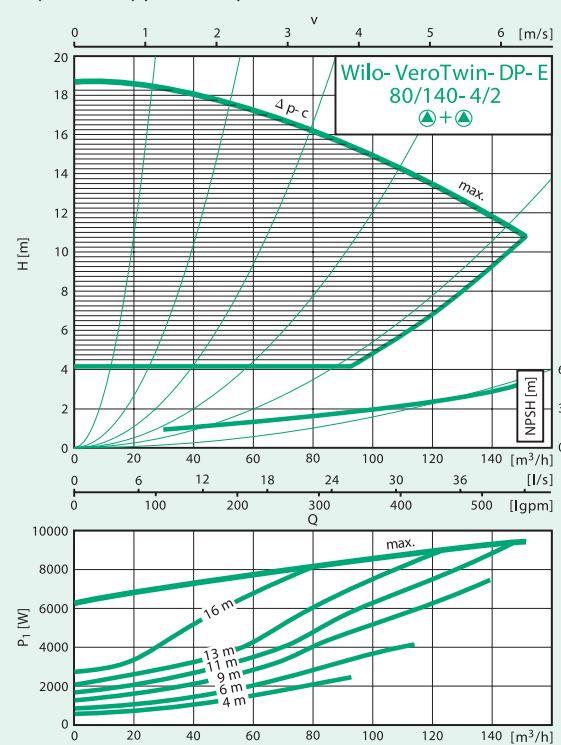

Δp -c (variable) parallel operation

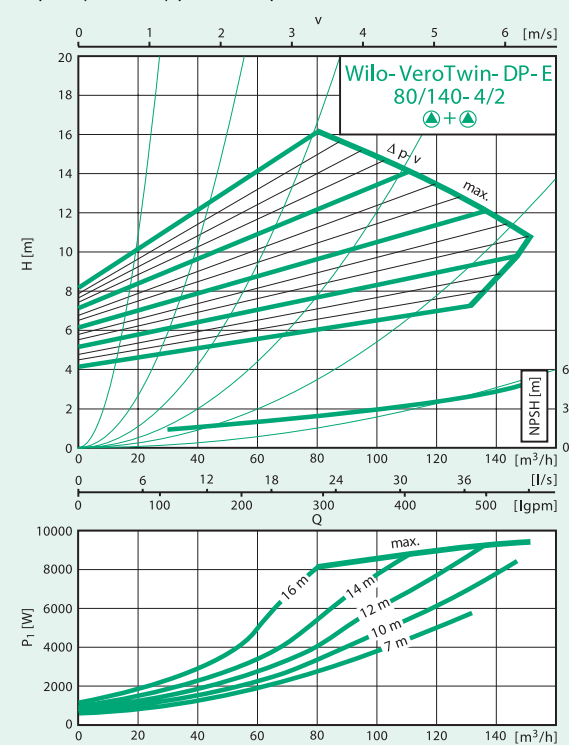

In-Line Pumps

DP-E Series



결선도 및 모터 Data

결선도

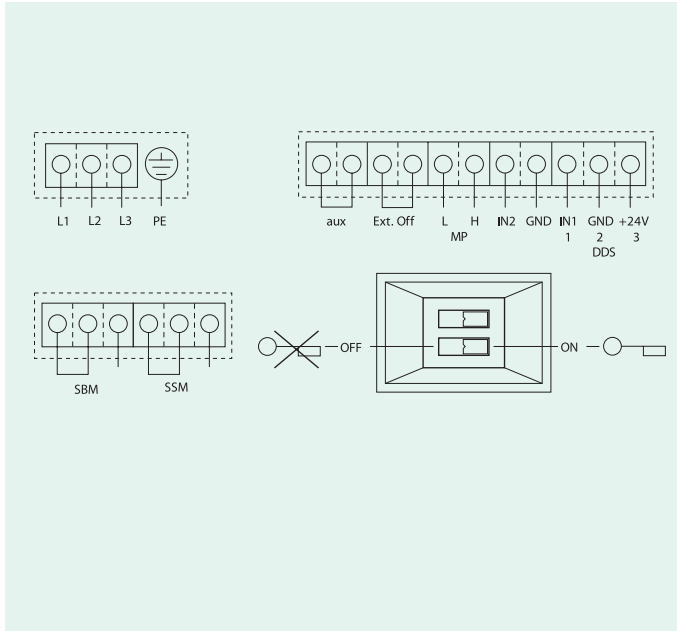

Switch rating of interference contacts for the collective run and Fault signal :

Min. 12 V DC/10 mA, max. 250 V AC/1A

L1, L2, L3, PE	Mains connection 3~400 V/50 Hz
SSM	Potential-free collective fault signal (NC contact in accordance with VDI 3814)
SBM	Potential-free collective run signal (NC contact in accordance with VDI 3814)
off	Control input "Overriding OFF"(24V)
PLR	Serial digital BA interface
DPM	Interface for the connection of a slave pump for fully-intergrated twin-head pump management
3	+24 V(Output) for ext. consumer/sensor
2	Earth(⊥)
1	0-10 V (Input) corresponds to 40%-100% for the nominal speed

Changeover key activated/ deactivated.

모터 DATA

Model	Nominal power P _{2max.} [kW]	Speed n [rpm]	Power consumption P ₁ [W]	Current I max [A]
DP-E 32/160-1,1/2	1,1	1200-2840	1350	3,7
DP-E 40/115-0,55/2	0,55	1150-2800	860	1,9
DP-E 40/150-3/2	3,0	1200-2890	3960	8,0
DP-E 40/160-4/2	4,0	1200-2900	4540	9,5
DP-E 50/115-0,75/2	0,75	1150-2850	1200	3,0
DP-E 50/140-3/2	3,0	1200-2890	4030	8,5
DP-E 50/150-4/2	4,0	1200-2900	4930	10,1
DP-E 65/115-1,5/2	1,5	1080-2860	1840	4,6
DP-E 65/130-3/2	3,0	1200-2890	4050	8,3
DP-E 65/140-4/2	4,0	1200-2890	4950	10,2
DP-E 80/115-2,2/2	2,2	1030-2880	2800	7,2
DP-E 80/130-3/2	3,0	1200-2900	3880	8,4
DP-E 80/140-4/2	4,0	1200-2900	4950	10,1

Three-phase motor (DM), 2-Pole-3~400V, 50Hz / 3~380V,60Hz

외형도

A

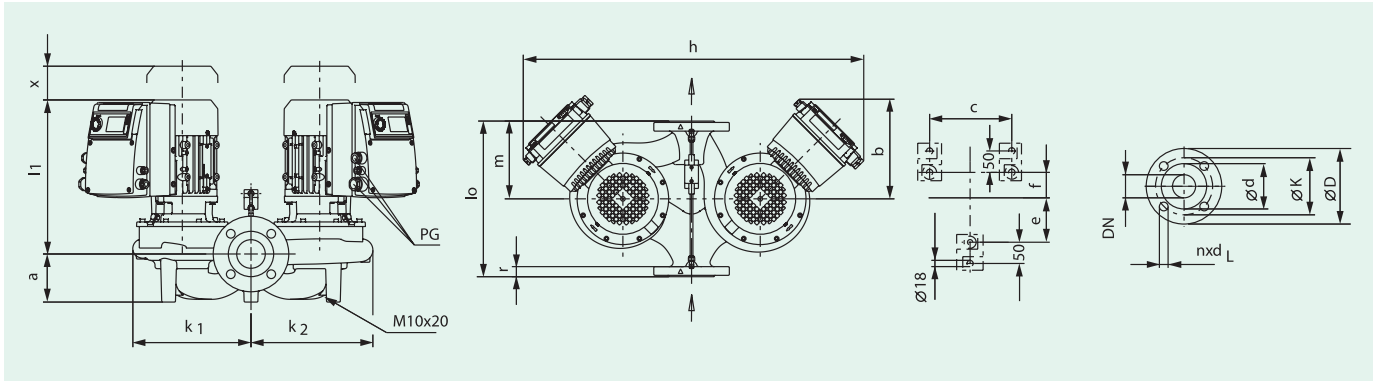

Note :
Housing with feet for installation in foundation and M10 holes.
Support brackets on request

B

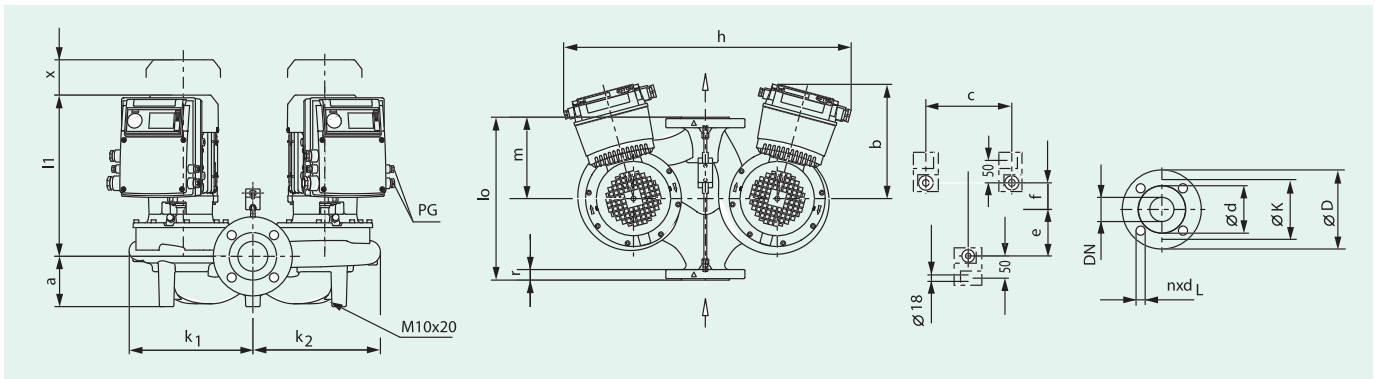

Note :
Housing with feet for installation in foundation and M10 holes.
Support brackets on request

C

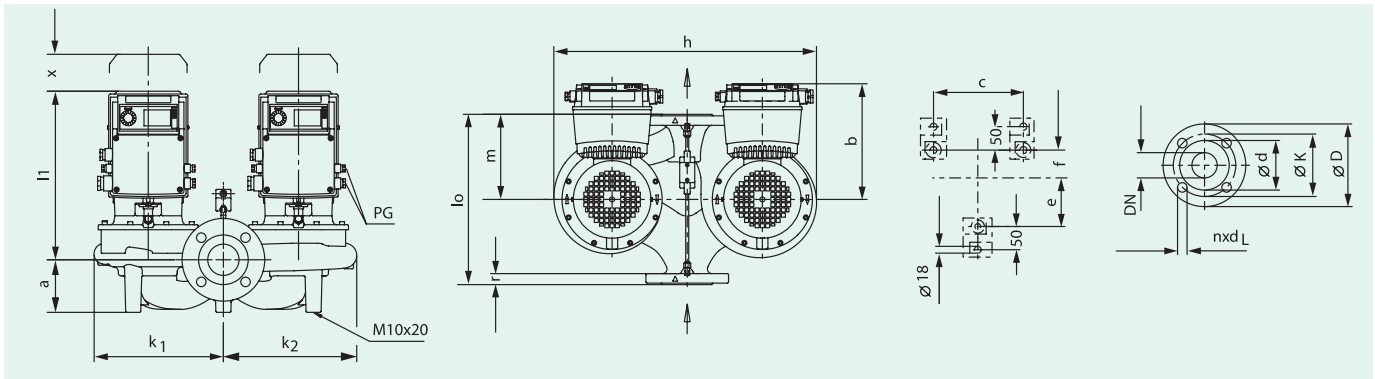

Note :
Housing with feet for installation in foundation and M10 holes.
Support brackets on request

In-Line Pumps

PIL Series



외형치수

외형치수

Model	Pipe con-nection/ nominal diameter	Pump dimensions													PG	Weight, approx.	Dimension drawing		
	-	l ₀	a	b	c	e	f	h	k ₁	k ₂	l ₁	m	r	x				-	-
	DN	[mm]																-	[kg]
DP-E 32/160-1.1/2	32	260	70	232	225	56	106	618	207	203	348	136	18	150	1x M25 1x M20 1x M16 2x M12	33	A		
DP-E 40/115-0.55/2	40	250	75	242	225	35	97	474	178	172	310	135	18	150		31	B		
DP-E 40/150-3/2	40	320	75	263	240	45	135	652	231	225	327	167	18	150		49	A		
DP-E 40/160-4/2	40	320	75	272	240	45	135	570	231	225	327	180	18	150		89	B		
DP-E 50/115-0.75/2	50	280	83	251	228	50	107	493	198	192	353	155	18	150		32	B		
DP-E 50/140-3/2	50	340	75	267	240	48	132	582	255	245	413	180	18	150		79	B		
DP-E 50/150-4/2	50	340	86	279	240	48	132	450	255	245	413	190	18	150		58	C		
DP-E 65/115-1.5/2	65	340	93	272	2250	25	137	531	223	209	389	185	18	150		42	B		
DP-E 65/130-3/2	65	340	93	267	240	43	137	490	280	270	409	185	18	150		59	C		
DP-E 65/140-4/2	65	340	93	272	240	43	137	550	280	270	409	180	18	150		98	C		
DP-E 80/115-2.2/2	80	360	100	272	240	43	137	561	249	231	391	205	18	150		53	B		
DP-E 80/130-3/2	80	360	103	267	240	40	150	480	249	231	413	192	18	150		89	C		
DP-E 80/140-4/2	80	360	103	279	240	30	150	520	307	294	413	192	18	150	68	C			

플랜지 규격

Model	Pipe connection/ nominal diameter	Flange dimensions, pumps-to EN 1092-2 PN16			
	-	D	d	k	n x d _t
	DN	[mm]			[no. x mm]
DP-E 32...	32	140	78	100	4 x 19
DP-E 40...	40	150	88	110	4 x 19
DP-E 50...	50	165	102	125	4 x 19
DP-E 65...	65	185	122	145	4 x 19
DP-E 80...	80	200	138	160	8 x 19

n=No. of bolt holes



설계 및 구조적 특징

1. 배관과 배관사이에 간편하게 설치할 수 있으며, 배관으로부터 펌프케이싱 분해 없이도 임펠러, 미캐니컬 실의 교환이 가능합니다.
2. 펌프와 모터축이 일체형으로 축이음 불량으로 인한 고장을 방지합니다.
3. 축봉장치는 펌프 내부의 유체로 윤활되는 미캐니컬 실이 장착됩니다.
4. 알루미늄 프레임 모터 채용으로 소형, 경량화를 구현 하였습니다.
(단, 15HP 이상은 주물 프레임)

표준사양

취 급 액		청수 0℃~120℃(pH6~8)
운전범위	유량	3~150m ³ /h
	양정	5~55m
	모터동력	1~40HP
최대운전압력		10 kgf/cm ² (option 16kgf/cm ² 가능)
구 조	임펠러	Closed Type
	축봉장치	Mechanical Seal type
플 랜 지		KS 10 kgf/cm ² RF(16kgf/cm ² RF option가능)
모 터	상,극수	3상, 4극
	전압	10HP 이하 : 220/380V 15HP 이상 : 380V(Y-△)
	주파수	60Hz
	절연등급	F종
	보호방식	IP44
	형식	전폐 외선형(TEFC)
설치장소		옥내형

※ 고온, 특수액을 취급할 경우에는 이송액의 특성(온도, 비중, 점도, 고형물의 유·무)과 사용조건에 따라 미캐니컬 실, 펌프 본체, Motor의 내마모성, 내식성이 현저히 변화하는 경우가 있으므로 반드시 영업 또는 공장으로 문의 하시기 바랍니다.

용도

- 빌딩의 냉, 온수 순환용
- 공동주택의 온수순환, 급탕 순환용
- 농업용의 유체 이송장치

최소 흡입 전양정

액의온도	흡입구경	흡입전양정
0℃ ~ 40℃	40~80mm	-6m이내
	100~125mm	-5.5m이내

흡입 전양정보정치

온 도	보 정 치
40℃ 이상~50℃ 이하	+1
50℃ 이상~60℃ 이하	+2
60℃ 이상~70℃ 이하	+3,5
70℃ 이상~80℃ 이하	+5
80℃ 이상~90℃ 이하	+7
90℃ 이상~95℃ 이하	+9
95℃ 이상~100℃ 이하	+11

선택사양

- Base Plate 부착
- 접액부 재질 변경
- 미캐니컬 실 재질 변경
- 상대 플렌지 부착
- 모터 형식, 구조, 동력, 주파수, 전압 변경

In-Line Pumps

PIL Series



모델명

표준 모델명

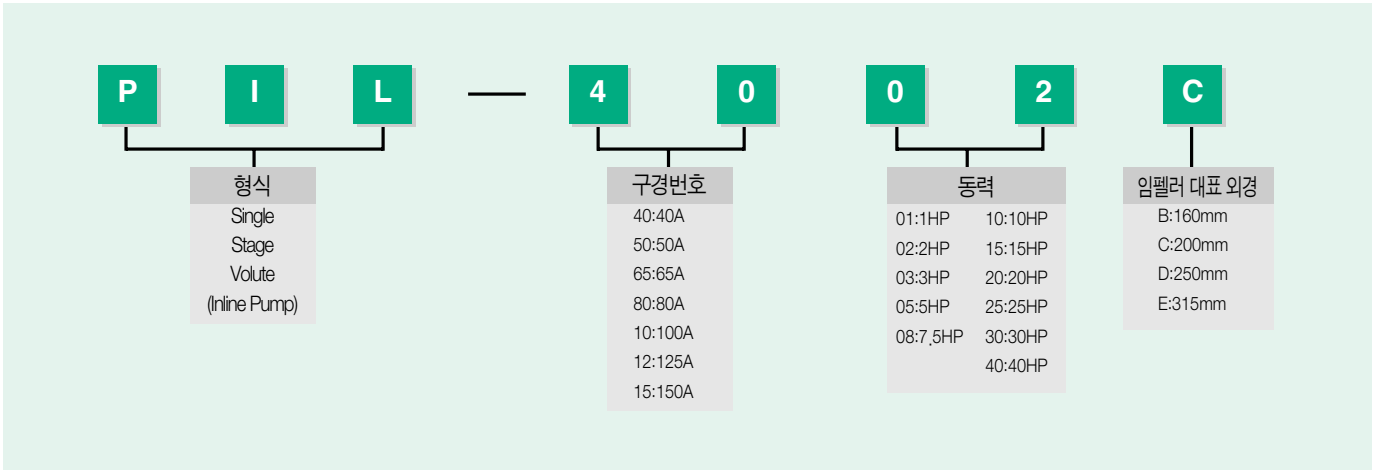

Option 모델명

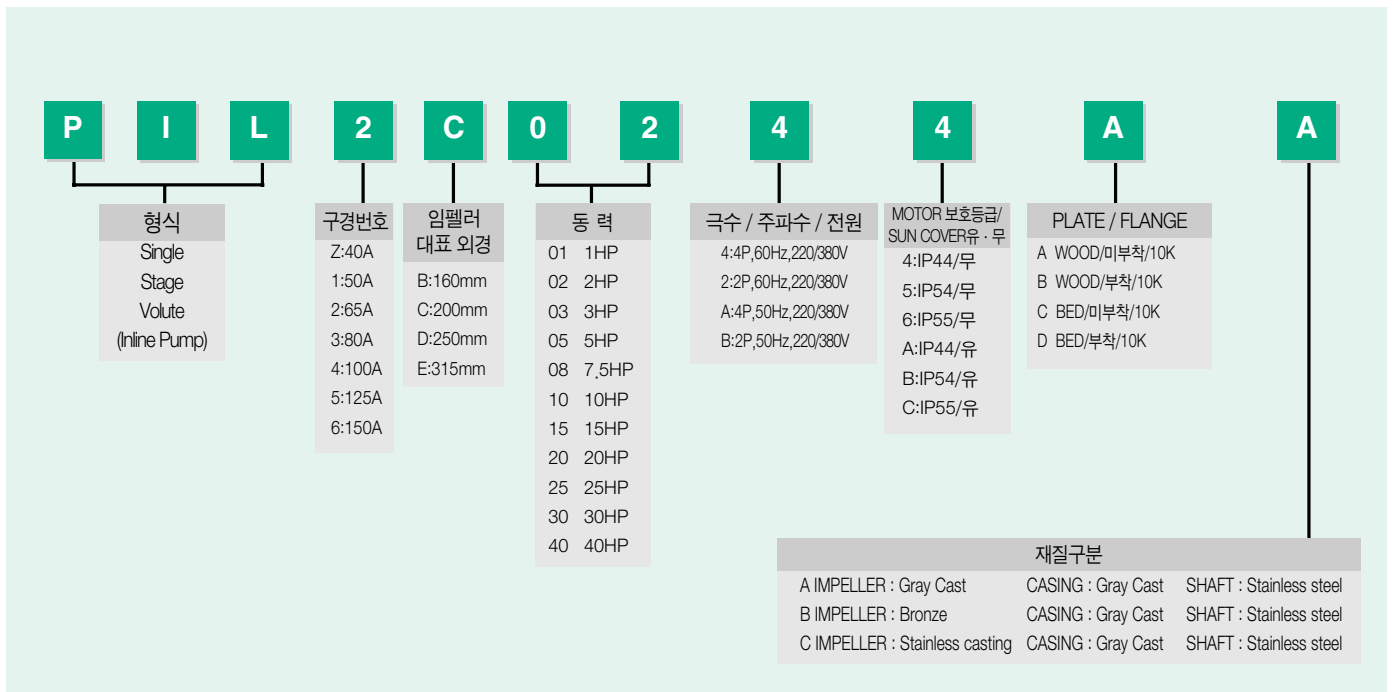

*기타 Option에 따라서 모델명 변경됨

선정도 (SELECTION CHART)

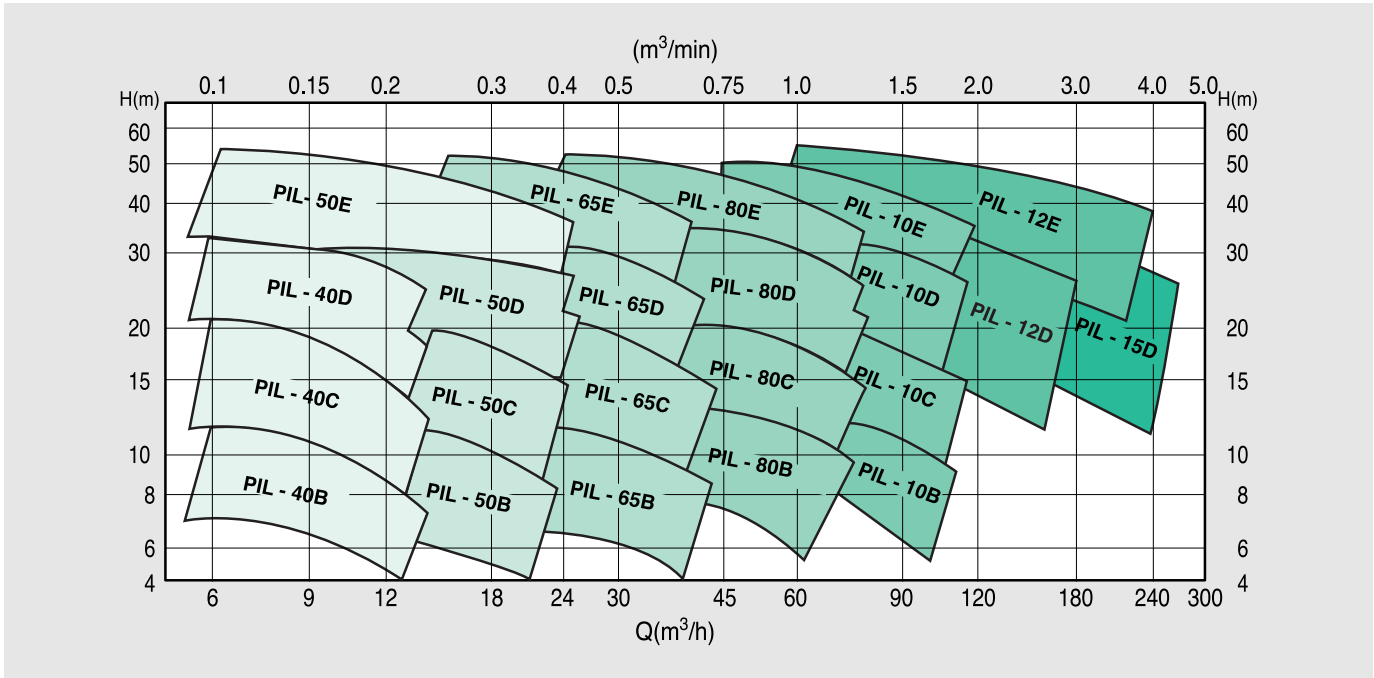

단면도 (SECTIONAL DRAWING)

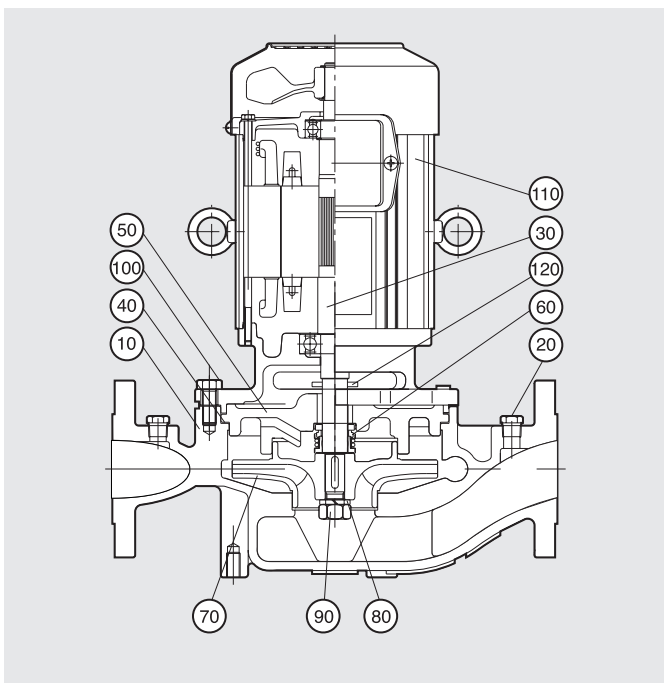

품 번	품 명	표 준
10	케이싱 (Casing)	Gary Cast Iron
20	플러그 (Plug)	Steel
30	축 (Shaft)	Stainless Steel
40	케이싱 가스켓 (Casing Gasket)	Rubber
50	케이싱 커버(Casing Cover)	Gary Cast Iron
60	미캐니컬 실 (M/Seal)	SiC/Carbon
70	임펠러 (Impeller)	Gary Cast Iron ★ (Bronze, Stainless Casting)
80	와셔 (Washer)	STS304
90	너트 (Nut)	Steel
100	볼트 (Bolt)	Steel
110	모터 (Motor)	-
120	물막음 턱 (Deflector)	Rubber

※ ★는 선택가능 재질임.
 ※ MOTOR의 Option은 영업 또는 공장에 문의 바랍니다.

In-Line Pumps

PIL Series



제품사양

인라인 펌프의 장점

1. 케이싱

- 흡입구에 정류판을 설치하여 흡입성능을 향상시키고, 순환수의 와류 및 케비테이션을 줄입니다.
- 16kgf/cm² (option)으로 가압조건에 사용가능 합니다. 단, 수격현상 (워터해머)에 대해서는 보증하지 않습니다.
- 흡입, 토출측에 압력을 측정 할 수 있도록 Plug(3/8",1/4")가 장착되어 있습니다.
- 지상 설치가 가능하도록 Tap이 설치되어 있습니다.
- 운전 정지시 펌프 내부에 유체를 제거 하도록 드레인 Plug(3/8")가 장착 되어 있습니다.

2. 임펠러

- Shell Core 구조법으로 수로부가 깨끗하여 유체의 흐름 손실을 줄였습니다.
- CAD 에 의한 3차원 Vane으로 양수성능이 우수합니다.
- STS304 재질의 임펠러 고정용 와셔는 내부식성이 우수합니다.

3. 마케니컬 실

- Carbon/Silicon Carbide 재질을 기본으로 장착하고 있어, 순환수 수온 120℃, X-Glycol 40% 혼합용액까지 사용 할 수 있습니다.
- 일시적인 역회전에서도 누수가 되지 않습니다.
- 케이싱 커버에 형성된 자체 Flusing 구멍은 윤활, 냉각 작용을 항상 시킵니다.
- 임펠러에 의해 고정되어 분해, 조립이 간편합니다.

4. 모 터

- 알루미늄 프레임(10HP 이하)을 적용하여 외관이 깨끗하고 열발산이 잘 되도록 냉각핀이 형성되어 있습니다.
- 16kgf/cm² 의 운전에도 견딜 수 있는 option모델 공급 가능하며, 밀폐형 볼 베어링을 장착 하였습니다.
- Shaft의 재질을 STS410으로 채용하여 내식성을 향상 시켰습니다.

표준 사양

Model	구경 (흡입*토출)	동력 (HP)	표준사양		사용유량 범위 (m ³ /H)	
			m ³ /Hr	m	최소	최대
PIL-4001B	40*40	1	7,2	10	3,6	15
PIL-4002B	40*40	2		13		
PIL-5001B	50*50	1	15	8	6	21
PIL-5002B	50*50	2		11,5		
PIL-6502B	65*65	2	30	9	10,2	36
PIL-6503B	65*65	3		11,5		
PIL-8003B	80*80	3	60	8	16,8	66
PIL-8005B	80*80	5		10,5		
PIL-1005B	100*100	5	94,8	8	27	102
PIL-1008B	100*100	7,5		10		
PIL-4002C	40*40	2	7,2	18	3,6	18
PIL-5003C	50*50	3	15	18	6	27
PIL-6503C	65*65	3	30	12	10,2	42
PIL-6505C	65*65	5		18		
PIL-8005C	80*80	5	60	12	16,8	78
PIL-8008C	80*80	7,5		18		
PIL-8010C	80*80	10		18		
PIL-1008C	100*100	7,5	96	12	27	105
PIL-1010C	100*100	10		15		
PIL-4003D	40*40	3	9	24	3,6	18
PIL-4005D	40*40	5		29		
PIL-5005D	50*50	5	15	24	6	27
PIL-5008D	50*50	7,5		29		
PIL-6505D	65*65	5	30	19	10,2	42
PIL-6508D	65*65	7,5		29		
PIL-8008D	80*80	7,5	60	18	16,8	78
PIL-8010D	80*80	10		24		
PIL-8015D	80*80	15		29		
PIL-1010D	100*100	10	96	15	27	105
PIL-1015D	100*100	15		24		
PIL-1020D	100*100	20		27		
PIL-1215D	125*125	15	150	15	42	168
PIL-1220D	125*125	20		21		
PIL-1225D	125*125	25		26		
PIL-1230D	125*125	30		28		
PIL-1525D	150*150	25	240	17	72	270
PIL-1530D	150*150	30		21		
PIL-1540D	150*150	40		26		
PIL-5008E	50*50	7,5	15	28	6	36
PIL-5010E	50*50	10		35		
PIL-5015E	50*50	15		50		
PIL-6510E	65*65	10	30	29	10,2	42
PIL-6515E	65*65	15		46		
PIL-8015E	80*80	15	60	29	16,8	78
PIL-8020E	80*80	20		36		
PIL-8025E	80*80	25		46		
PIL-1020E	100*100	20	94,8	30	27	120
PIL-1025E	100*100	25		34		
PIL-1030E	100*100	30		41		
PIL-1230E	125*125	30	150	31	42	168
PIL-1240E	125*125	40		42		

외형치수도 (OUTLINE DIMENSIONS)

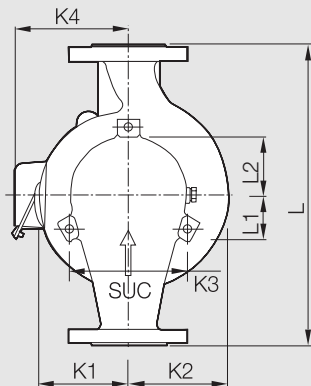
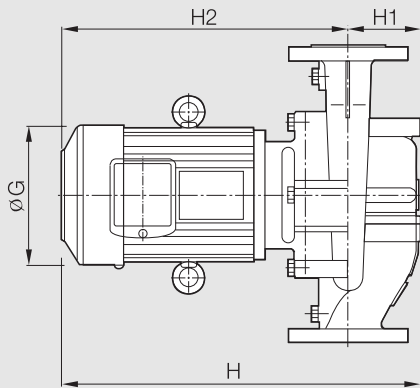

Model	H	H1	K1	K2	K3	K4	L	L1	L2	ØG	Wt. (kg)
PIL-400 1B	435	90	123	123	139	148	390	40	80	182	52
PIL-400 2B	475	90	123	123	139	148	390	40	80	182	53
PIL-500 1B	440	95	123	130	154	148	440	44.5	89	182	53
PIL-500 2B	480	95	123	130	154	148	440	44.5	89	182	54
PIL-650 2B	497	110	123	138	154	148	474	44.5	89	182	60
PIL-650 3B	497	110	123	138	154	164	474	44.5	89	213	64
PIL-800 3B	522	130	131	155	170	164	524	49	95	213	66
PIL-800 5B	552	130	131	155	170	164	524	49	95	213	74
PIL-100 5B	577	150	137	170.5	195	164	574	55	110	213	102
PIL-100 8B	587	150	137	170.5	195	224	574	55	110	274	110
PIL-400 2C	430	90	145	146	130	150	390	30	0	174	53
PIL-500 3C	461	100	145	149	154	167	440	60	85	218	65
PIL-650 3C	477	110	149	167	154	167	475	60	85	218	71
PIL-650 5C	507	110	149	167	154	167	475	60	85	218	80
PIL-800 5C	540	130	156	180	170	167	500	65	95	218	89
PIL-800 8C	577	130	156	180	170	185	500	65	95	248	93
PIL-100 8C	609	150	154	184	195	185	550	55	110	248	99
PIL-101 0C	636	150	154	184	195	185	550	55	110	248	107
PIL-400 3D	455	90	176	176	154	167	474	44.5	89	218	72
PIL-400 5D	485	90	176	176	154	167	474	44.5	89	218	81
PIL-500 5D	496	100	176	186	154	167	474	44.5	89	218	76
PIL-500 8D	533	100	176	186	154	185	474	44.5	89	248	80
PIL-650 5D	512	115	176	176	195	167	524	55	110	218	88
PIL-650 8D	549	115	176	176	195	185	524	55	110	248	92
PIL-800 8D	600	130	176	194	195	185	550	55	110	248	105
PIL-801 0D	613	130	176	194	195	185	550	55	110	248	110
PIL-801 5D	670	130	176	194	195	265	550	55	110	317	180
PIL-101 0D	637	140	185	212	225	185	620	65	130	248	120
PIL-101 5D	694	140	185	212	225	265	620	65	130	317	180
PIL-102 0D	738	140	185	212	225	265	620	65	130	317	183
PIL-121 5D	754	165	182	212	250	265	700	72	144	317	187
PIL-122 0D	754	165	182	212	250	265	700	72	144	317	230
PIL-122 5D	754	165	182	212	250	299	700	72	144	358	248
PIL-123 0D	754	165	182	212	250	299	700	72	144	358	261
PIL-152 5D	794	200	197	240	286	265	750	82.5	165	317	262
PIL-153 0D	794	200	197	240	286	299	750	82.5	165	358	274
PIL-154 0D	814	200	197	240	286	299	750	82.5	165	358	292
PIL-500 8E	550	110	203	203	195	185	524	55	110	248	98
PIL-501 0E	580	110	203	203	195	185	524	55	110	248	100
PIL-501 5E	644	110	203	203	195	265	524	55	110	317	170
PIL-651 0E	601	130	202	212	195	185	600	55	110	248	102
PIL-651 5E	665	130	202	212	195	265	600	55	110	317	179
PIL-801 5E	695	150	203	218	195	265	650	55	110	317	200
PIL-802 0E	739	150	203	218	195	265	650	55	110	317	225
PIL-802 5E	739	150	203	218	195	299	650	55	110	358	242
PIL-102 0E	744	165	205	222	225	299	700	65	130	358	230
PIL-102 5E	744	165	205	222	225	299	700	65	130	358	250
PIL-103 0E	744	165	205	222	225	299	700	65	130	358	256
PIL-123 0E	769	185	220	245	250	299	700	72	144	358	274
PIL-124 0E	769	185	220	245	250	299	700	72	144	358	292

★ 상기치수는 성능 향상 및 공급처에 따라 변경 될 수 있습니다.

In-Line Pumps

PIL Series



성능곡선

PIL- 4001B~PIL- 4002C

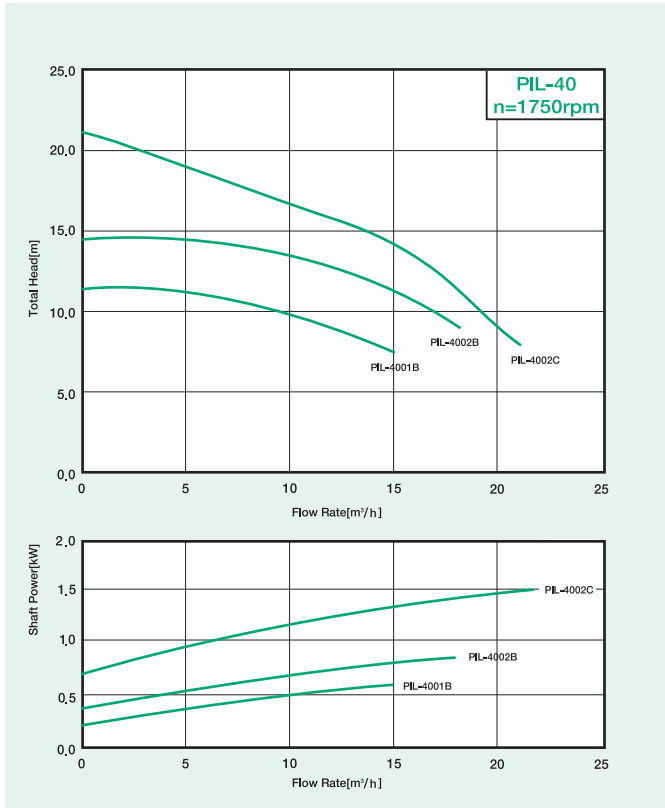

PIL- 5001B~PIL- 5008D

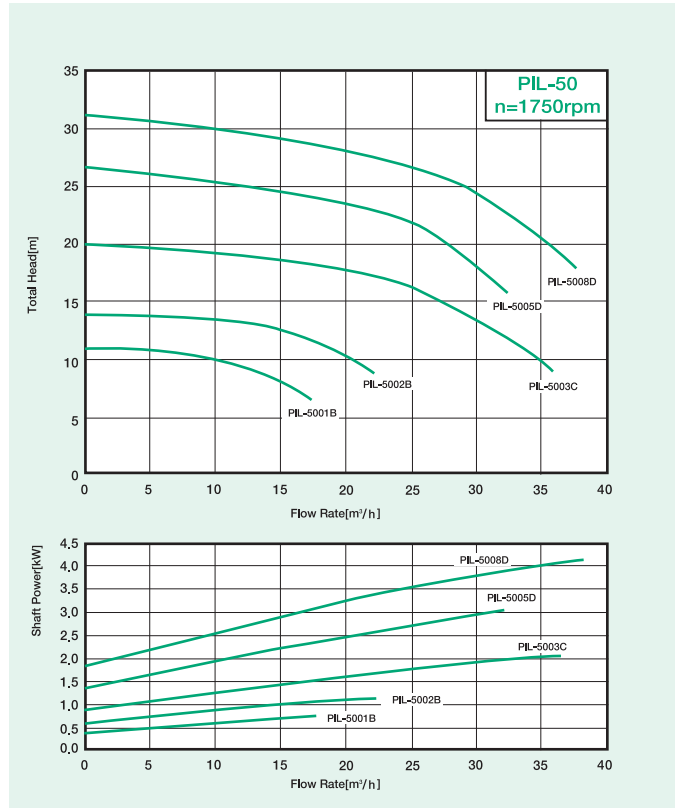

PIL- 4003D~PIL- 4005D

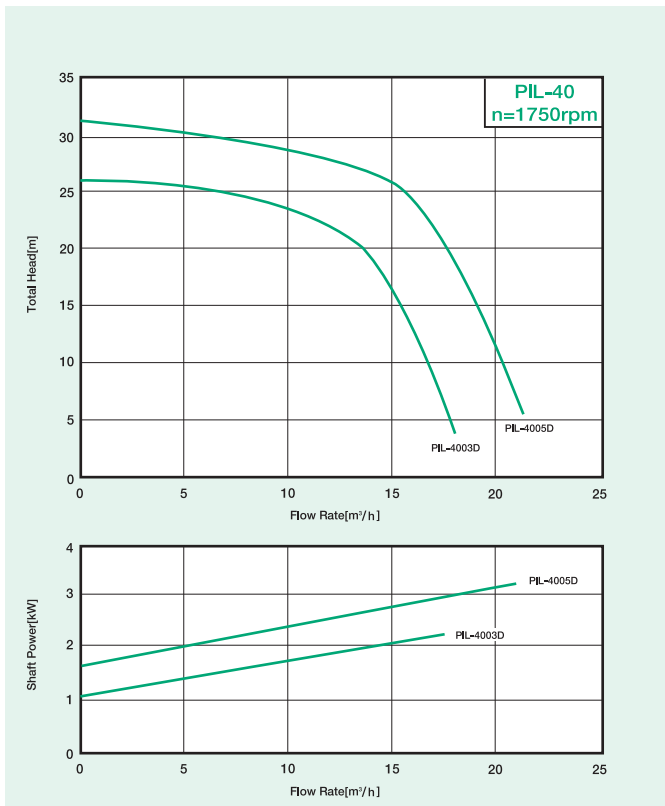

PIL- 5008E~PIL- 5015E

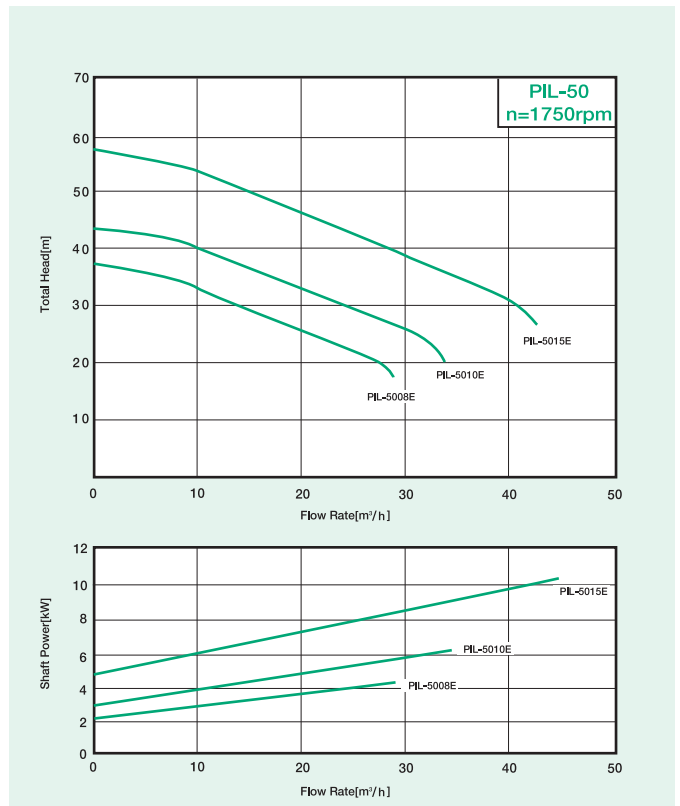

PIL- 6502B~PIL- 6505C

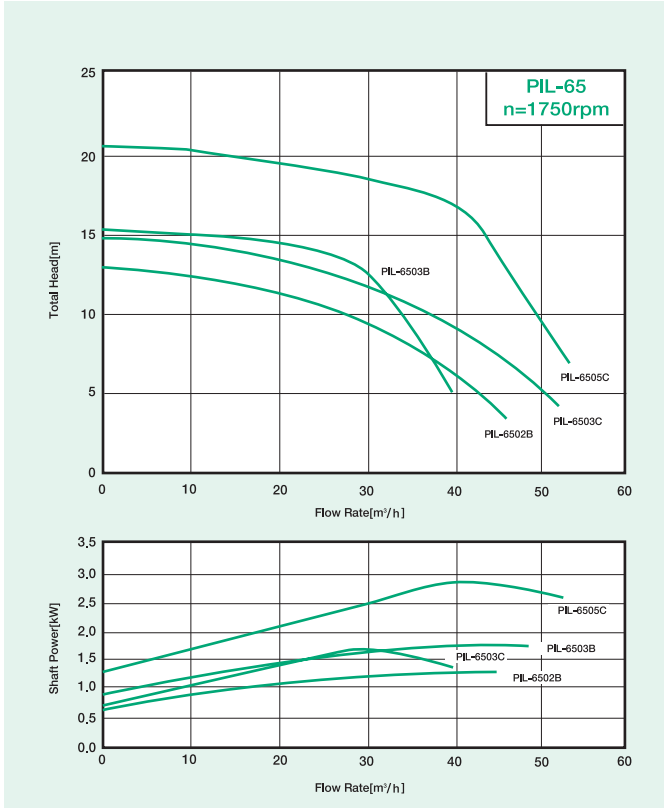

PIL- 8003B~PIL- 8008C

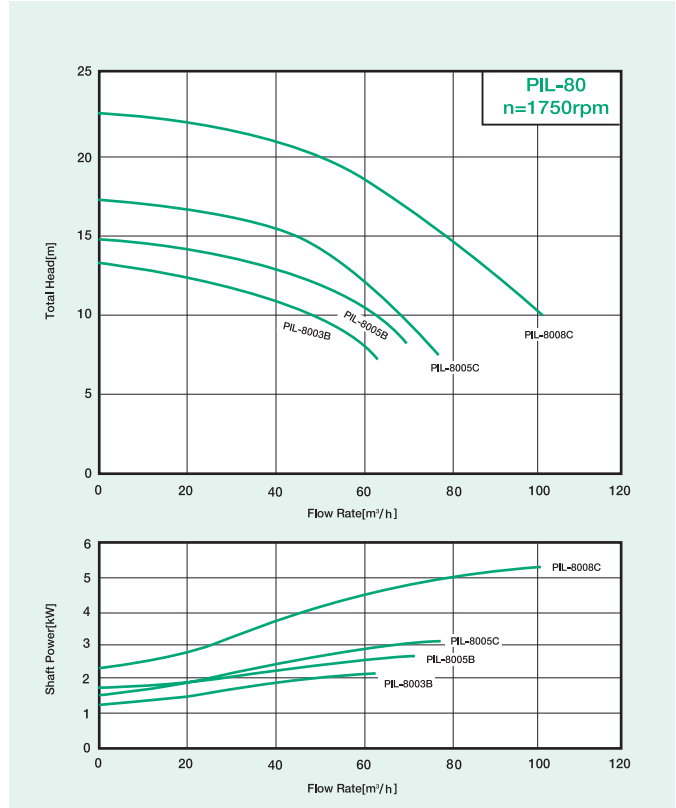

PIL- 6505D~PIL- 6515D

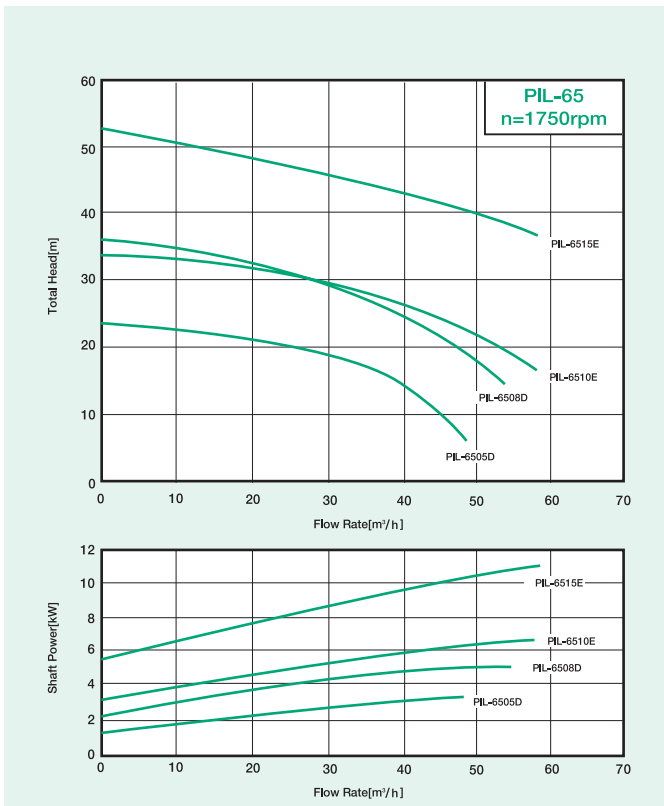

PIL- 8008D~PIL- 8025E

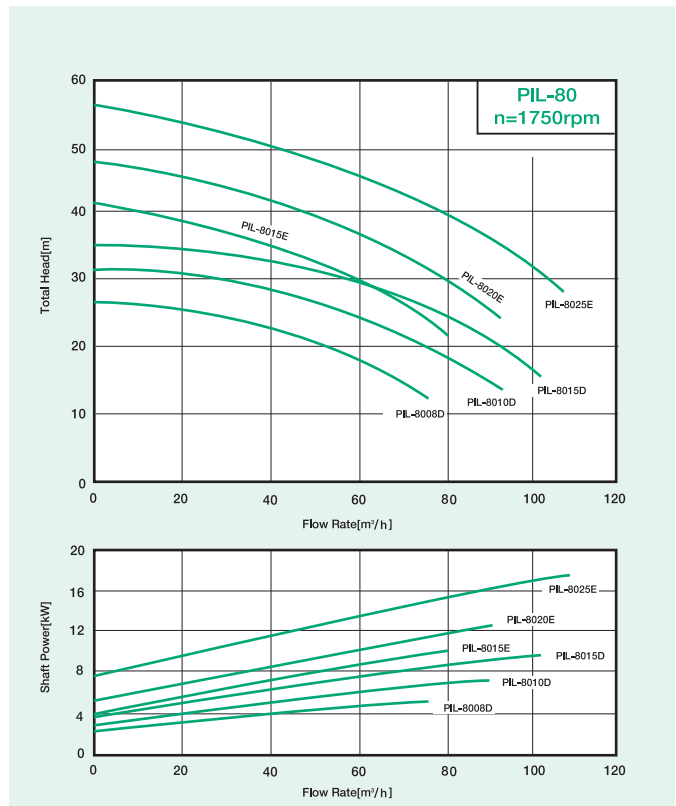

In-Line Pumps

PIN Series



성능곡선

PIL- 1005B~PIL- 1010C

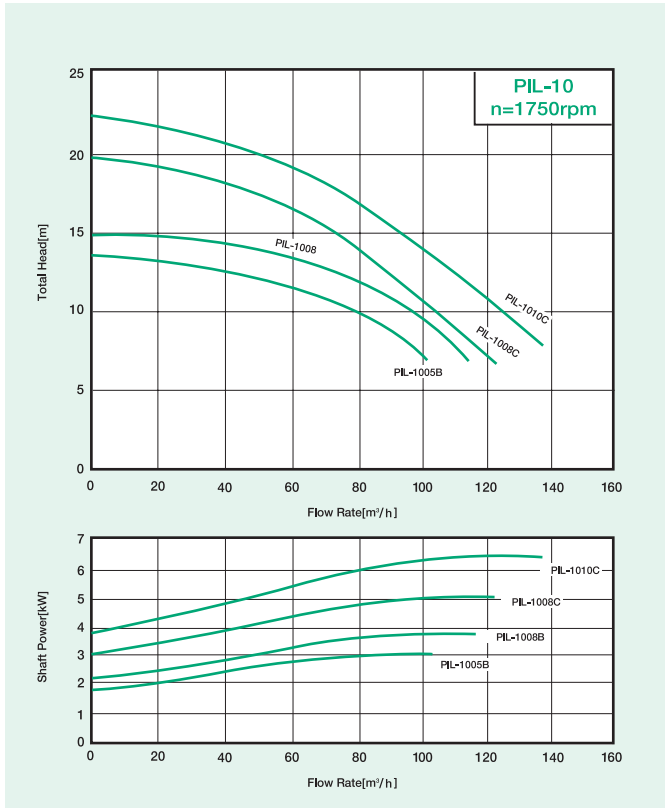

PIL- 1225D~PIL- 1240E

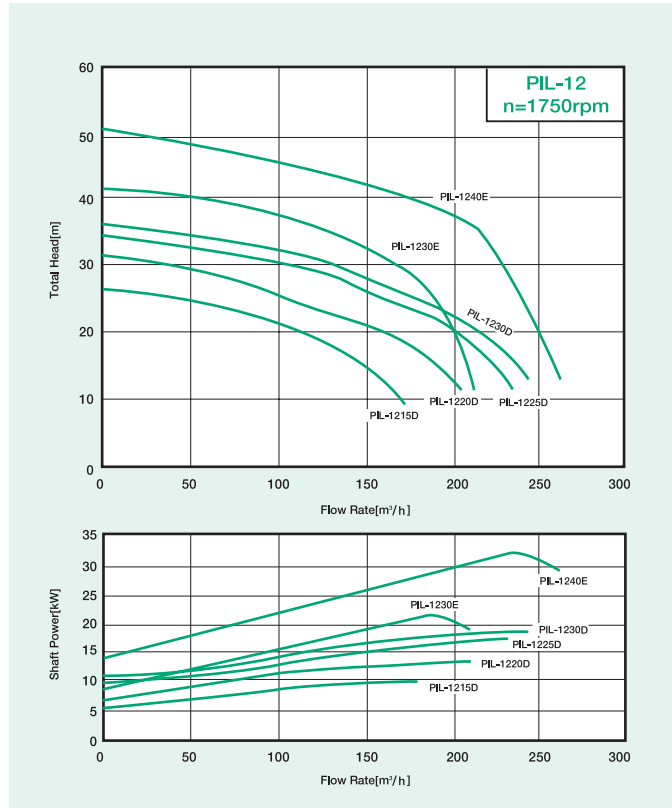

PIL- 1010D~PIL- 1030E

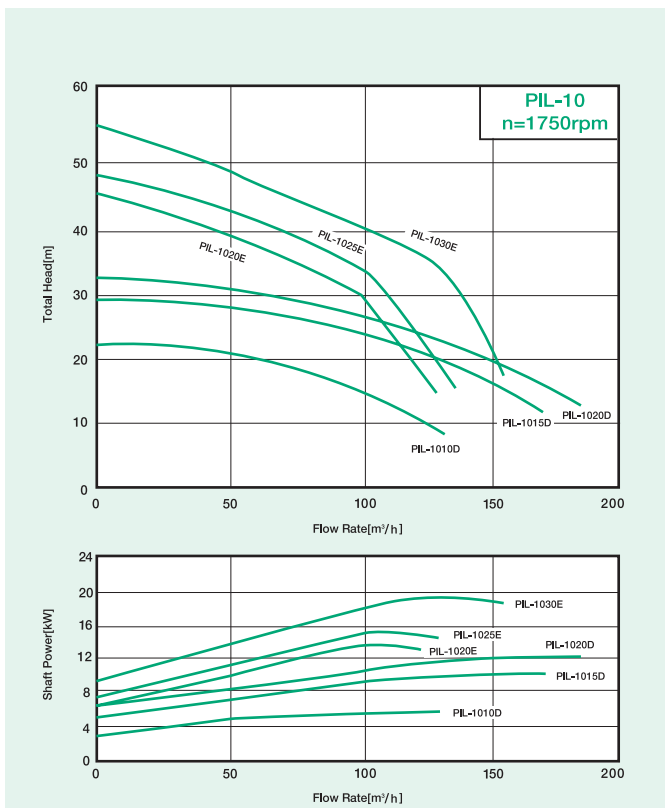

PIL- 1530D~PIL- 1540D

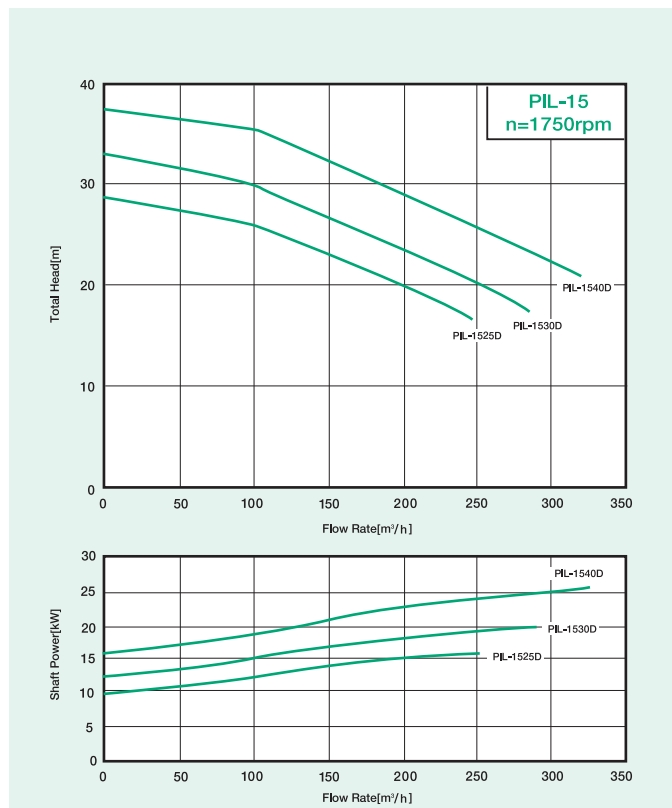



설계 및 구조적 특징

1. 배관사이에 간편하게 설치되므로 플렉시블 방진가대의 설치가 필요 없습니다.
2. 설치공간이 작고 가벼우며, 분해 및 조립이 간편합니다.
3. 펌프와 모터축이 일체형 구조로 진동, 소음이 적습니다.

용도

- 빌딩, 온수 순환용
- 공동주택의 온수순환, 급탕순환용
- 농업용의 유체 이송장치
- 최대허용 사용압력 : 3kgf/cm²
- 최대허용 사용온도 : 0~80℃

제품사양표

MODEL	구경(mm)		동력 (HP)	유량 (m ³ /h)	양정 (m)	총중량 (kg)
	흡입	토출				
PIN - 4001	40	40	1	7,2	10	35
PIN - 5001	50	50	1	7,2	10	35
PIN - 5002	50	50	2	14,4	10	43
PIN - 6502	65	65	2	14,4	10	43
PIN - 6503	65	65	3	30	10	56
PIN - 8003	80	80	3	30	10	56

cf. PIN-5001, 6502, 8003은 상대 플랜지의 구경만 변경하여 적용하는 MODEL임.

외형치수도 (OUTLINE DIMENSIONS)

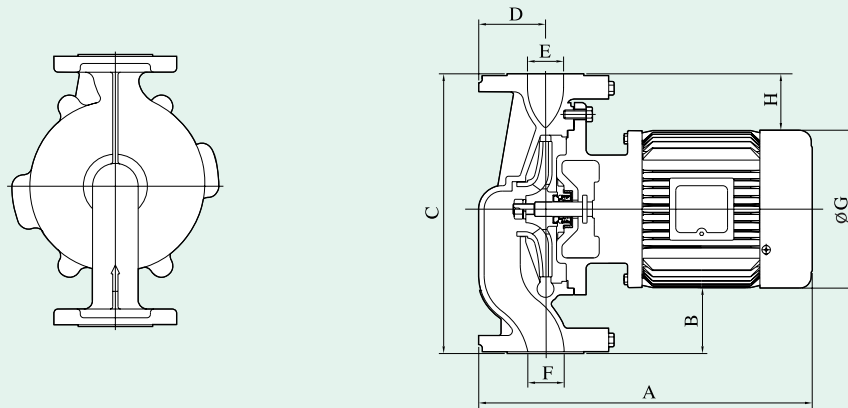

MODEL	PHASE	OUTPUT	A	B	C	D	E	F	øG	H	Fr. No
PIN-4001/5001	3상	0,75kW	371	73	310	74	ø 40	ø 40	175	62,5	80M
PIN-5002/6502		1,5kW	431	74	330	79,5	ø 50	ø 50	193	62,5	90M
PIN-6503/8003		2,2kW	464	72	380	89,5	ø 65	ø 65	236	72,3	112M

In-Line Pumps

IPA Series



성능곡선

PIN- 4001/5001

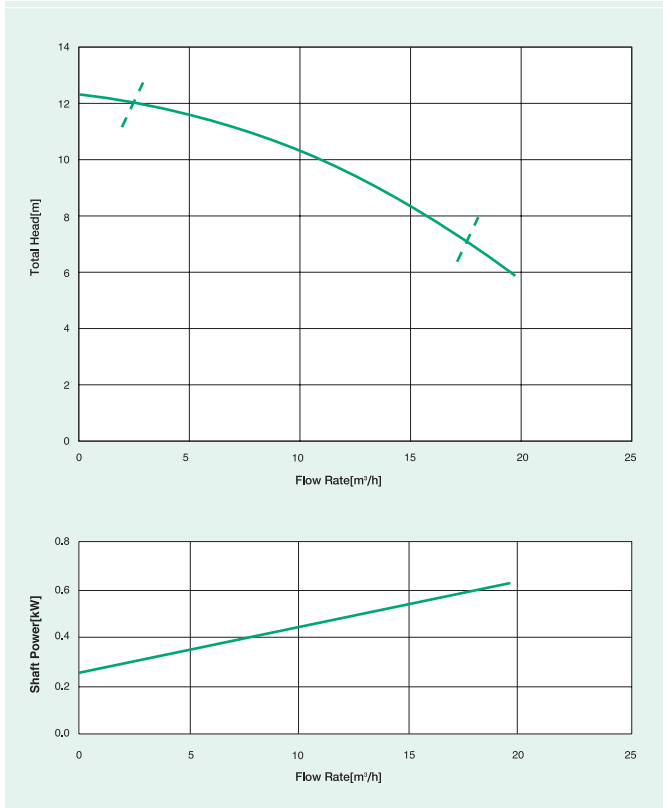

PIN-5002/6502

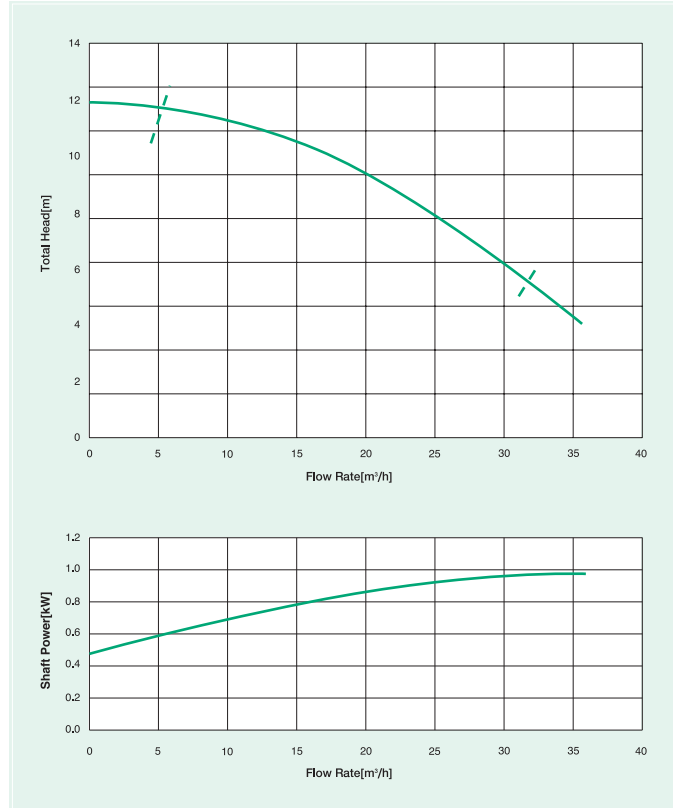

PIN-6503/8003

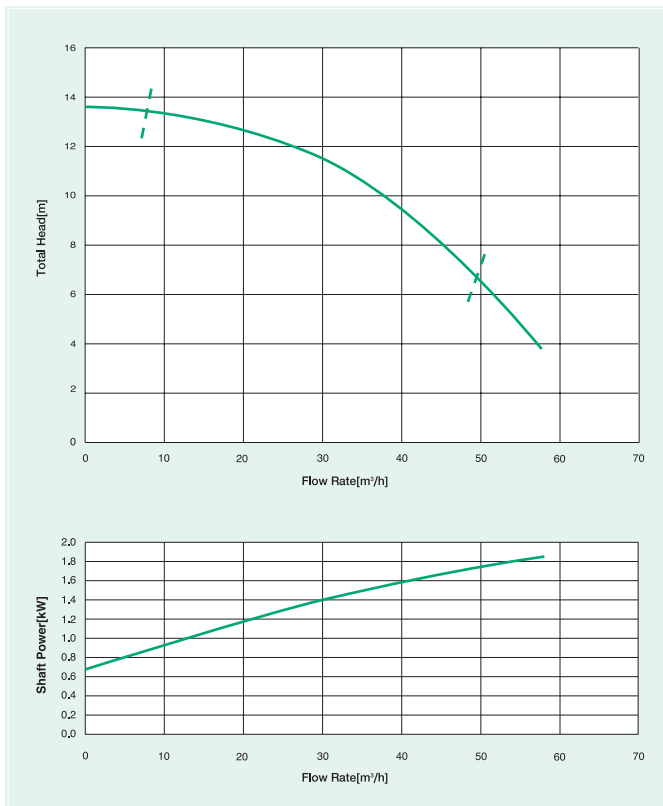



Pumpen Intelligenz.