

# MILLING CHUCK

MAS - BT 403

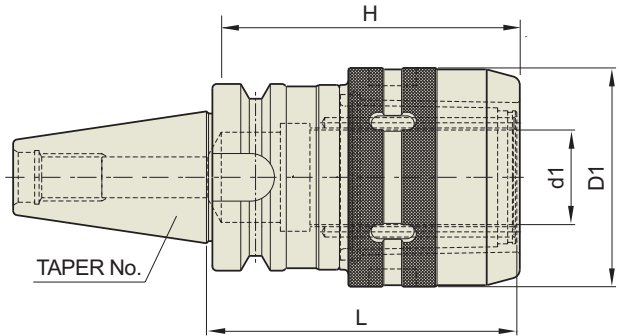

MAS - BT 403	Taper Accuracy AT3	G Value	RPM	Coolant System
-----------------	--------------------------	---------	-----	-------------------

TAPER No.	CODE No.	d1	D1	L	H	적용 COLLET	중량 (KG)	재고
30	BT30-C20- 75	20	54	75	70	K20, CK20	1.5	●
	BT30-C25- 80	25	62.5	80	80	K25, CK25	2.0	●
40	BT40-C20- 80	20	54	80	70	K20, CK20	2.0	●
	BT40-C20-105	20	54	105	70	K20, CK20	2.1	●
	BT40-C25-105	25	62.5	105	80	K25, CK25	2.5	
	BT40-C32- 90	32	72	90	100	K32, CK32	3	●
	BT40-C32-105	32	72	105	100	K32, CK32	3.1	●
	BT40-C32-135	32	72	135	100	K32, CK32	3.3	
50	BT50-C20-105	20	54	105	70	K20, CK20	4.5	●
	BT50-C20-135	20	54	135	70	K20, CK20	4.9	
	BT50-C20-165	20	54	165	70	K20, CK20	5.4	●
	BT50-C25-105	25	62.5	105	80	K25, CK25	5.2	
	BT50-C25-135	25	62.5	135	80	K25, CK25	5.8	
	BT50-C25-165	25	62.5	165	80	K25, CK25	6.2	
	BT50-C32-105	32	72	105	100	K32, CK32	6	●
	BT50-C32-115	32	72	115	100	K32, CK32	6.2	
	BT50-C32-135	32	72	135	100	K32, CK32	6.7	●
	BT50-C32-165	32	72	165	100	K32, CK32	7.4	●
	BT50-C42-115	42	92	115	110	K42, CK42	6.7	●
	BT50-C42-135	42	92	135	110	K42, CK42	7.6	●
BT50-C42-165	42	92	165	110	K42, CK42	8.3		

## SPARE PARTS

END MILL COLLET	CODE No.	SET
	K20 - 6, 8, 10, 12, 16	5PCS
	K25 - 6, 8, 10, 12, 16, 20	6PCS
	K32 - 6, 8, 10, 12, 16, 20, 25	7PCS
	K42 - 6, 8, 10, 12, 16, 20, 25, 32	8PCS

END MILL COLLET	CODE No.	SET
	CK20 - 6, 8, 10, 12, 16	5PCS
	CK25 - 6, 8, 10, 12, 16, 20	6PCS
	CK32 - 6, 8, 10, 12, 16, 20, 25	7PCS
	CK42 - 6, 8, 10, 12, 16, 20, 25, 32	8PCS

SPANNER	CODE No.
	C20 SP
	C25 SP
	C32 SP
	C42 SP

# MILLING CHUCK

## HSK FORM A

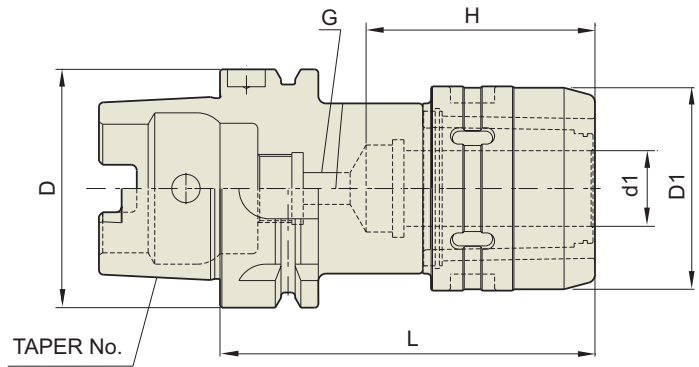

DIN69893 - HSK	Taper Accuracy AT3	G Value	RPM	Coolant System
-------------------	--------------------------	---------	-----	-------------------

TAPER No.	CODE No.	D	d1	D1	L	H	G	중량 (KG)	재고
50A	HSK 50A-C20-100	50	20	54	100	70	M12	1.30	
63A	HSK 63A-C20-105	63	20	54	105	70	M12	1.50	●
	HSK 63A-C32-130	63	32	72	130	100	M12	2.70	●
100A	HSK100A-C20-110	100	20	54	110	70	M12	3.50	
	HSK100A-C32-135	100	32	72	135	100	M12	4.20	
	HSK100A-C42-135	100	42	92	135	100	M12	5.30	

### SPARE PARTS

END MILL COLLET	CODE No.	SET
	K20 - 6, 8, 10, 12, 16	5PCS
	K32 - 6, 8, 10, 12, 16, 20, 25	7PCS
	K42 - 6, 8, 10, 12, 16, 20, 25, 32	8PCS

▶ SPECIAL SIZE Ø3, Ø4, Ø5 제작가능

END MILL COLLET	CODE No.	SET
	CK20 - 6, 8, 10, 12, 16	5PCS
	CK25 - 6, 8, 10, 12, 16, 20	6PCS
	CK32 - 6, 8, 10, 12, 16, 20, 25	7PCS
	CK42 - 6, 8, 10, 12, 16, 20, 25, 32	8PCS

SPANNER	CODE No.
	C20 SP
	C25 SP
	C32 SP
	C42 SP

## MILLING CHUCK

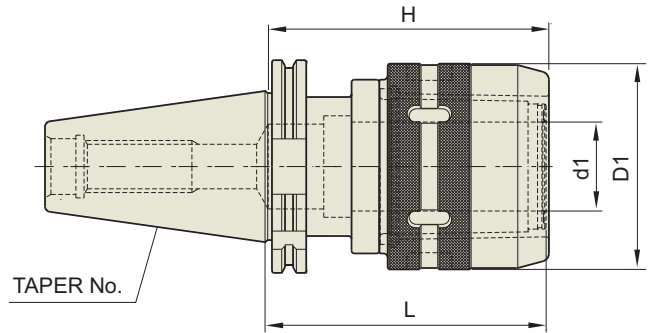

DIN69871 -SK	Taper Accuracy AT3	G Value	RPM	Coolant System
-----------------	--------------------------	---------	-----	-------------------

### ■ STUB

TAPER No.	CODE No.	d1	D1	L	H	중량 (KG)	재고
30	SK30-C20-80	20	54	80	70	1.15	
	SK30-C25-80	25	62.5	80	80	1.48	
40	SK40-C20-90	20	54	90	70	1.60	
	SK40-C32-90	32	72	90	100	2.00	
50	SK50-C20-80	20	54	80	70	3.22	
	SK50-C25-90	25	62.5	90	80	3.61	
	SK50-C32-90	32	72	90	100	3.87	

### ■ STANDARD

TAPER No.	CODE No.	d1	D1	L	H	중량 (KG)	재고
40	SK40-C20-105	20	54	105	70	1.77	
	SK40-C25-105	25	62.5	105	80	2.01	
	SK40-C32-105	32	72	105	100	2.42	
50	SK50-C20-105	20	54	105	70	3.39	
	SK50-C25-105	25	62.5	105	80	3.78	
	SK50-C32-105	32	72	105	100	4.31	
	SK50-C42-115	42	92	115	110	4.53	

### ■ EXTENDED

TAPER No.	CODE No.	d1	D1	L	H	중량 (KG)	재고
40	SK40-C32-135	32	72	135	100	3.11	
50	SK50-C32-135	32	72	135	100	4.94	
	SK50-C42-135	42	92	135	110	5.62	

### ■ EXTRA EXTENDED

TAPER No.	CODE No.	d1	D1	L	H	중량 (KG)	재고
50	SK50-C32-165	32	72	165	100	5.59	
	SK50-C42-165	42	92	165	110	6.10	

MILLING CHUCK

MILLING CHUCK

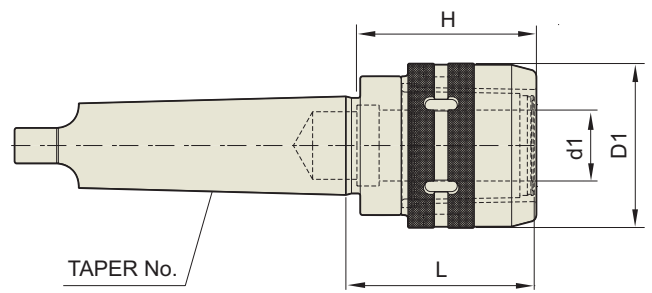

DIN 228 - MTA	Taper Accuracy AT3	G Value	RPM	Coolant System
---------------	--------------------	---------	-----	----------------

TAPER No.	CODE No.	d1	D1	L	H	적용 COLLET	중량 (KG)	재고
MT4	MTA4-C32	32	72	98	100	K32, CK32	2.57	
MT5	MTA5-C32	32	72	85	100	K32, CK32	3.06	
	MTA5-C42	42	92	114	110	K42, CK42	3.45	
MT6	MTA6-C42	42	92	99	110	K42, CK42	4.14	●

▶ MT6 TYPE은 CUTTER HOME 선정을 위한 기계 Model 및 회사명을 알려주십시오.

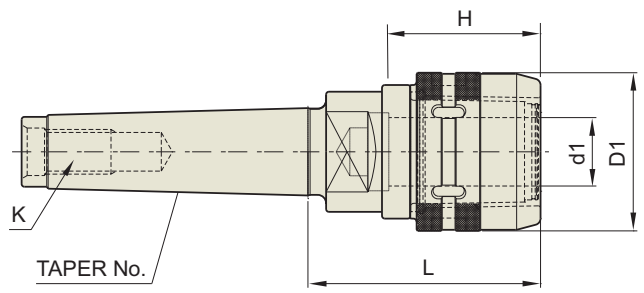

DIN 228 - MTB	Taper Accuracy AT3	G Value	RPM	Coolant System
---------------	--------------------	---------	-----	----------------

TAPER No.	CODE No.	d1	D1	L	H	K	적용 COLLET	중량 (KG)	재고
MT3	MTB3-C20	20	54	74	70	M12	K20, CK20	2.10	●
MT4	MTB4-C32	32	72	98	100	M16	K32, CK32	2.57	
	MTB5-C32	32	72	85	100	M20	K32, CK32	3.06	●
MT5	MTB5-C42	42	92	114	110	M20	K42, CK42	3.45	

# MILLING CHUCK

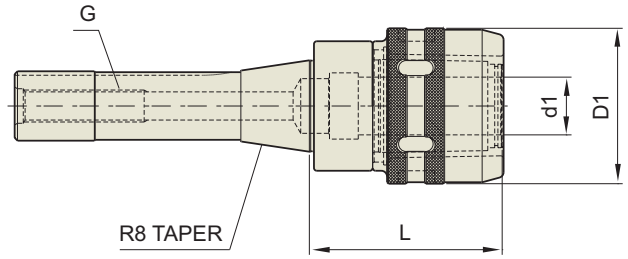

R8	Taper Accuracy AT3	G Value	RPM	Coolant System
----	-----------------------	---------	-----	----------------

TAPER No.	CODE No.	d1	D1	L	G	적용 COLLET	중량 (KG)	재고
R8	R8-C20	20	54	69	U7/16-20	K20, CK20	1.40	●