

# SNS HCB CLAMSHELL BUCKET

## Features

- Single cylinder type is designed for improving digging force and only available free rotating.
- Using of AR400 steel at wear surface and edges.
- Highly qualified hydraulic parts for reliability.
- Various options available for customer's working condition.

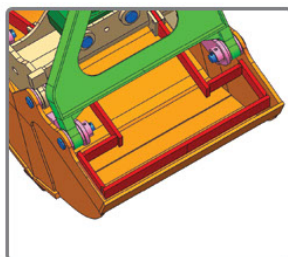
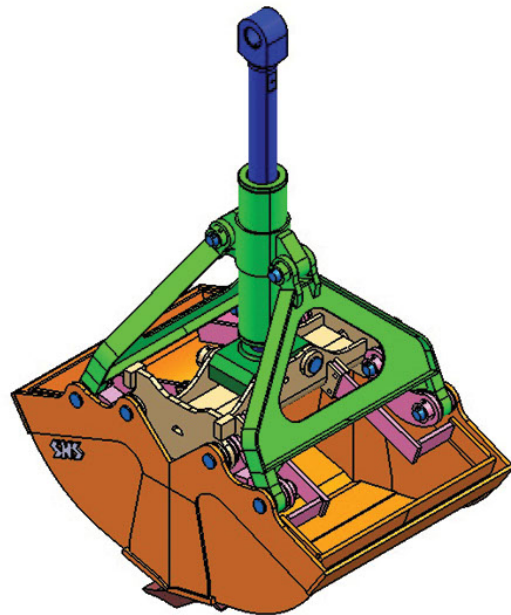
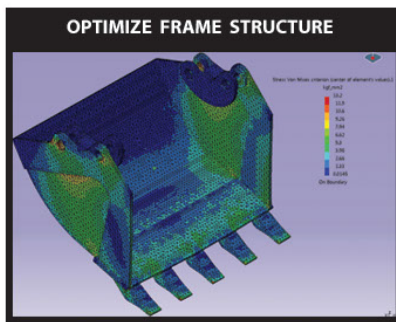

### EJECTOR

USEFUL FOR COHESIVE AND CLAYED TERRAIN

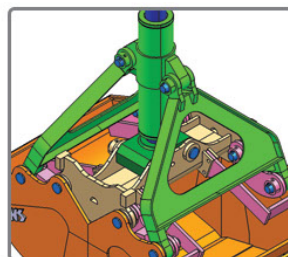

### PINS

OVERSIZED PINS WITH BRONZE BUSINGS FOR LONG LIFE

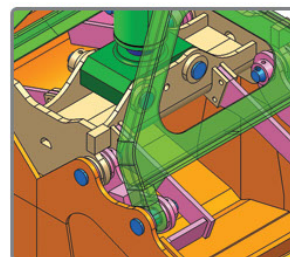

### LINKS

SYNCHRO LINK SYSTEM FOR SYNCHRONIZING BUCKET'S MOVING

## OPTIONS

### BUCKET SHELL TYPE

- TOOTH TYPE
- WITHOUT TOOTH TYPE

### ROTATION TYPE

- (M) FREE ROTATION ONLY

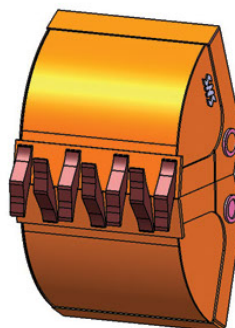

TOOTH TYPE

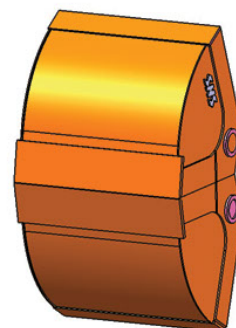

WITHOUT TOOTH TYPE



SNS MODEL	CAPACITY		A		B		C		H		H1		WEIGHT	
	cu.m	cu.yd	mm	ins	mm	ins	mm	ins	mm	ins	mm	ins	kgs	lbs
<b>HC20-06M</b>	0.70	0.92	1608	66.30	1865	73.70	900	35.40	2136	84.10	2375	93.50	1198	2718
<b>HC20-08M</b>	0.80	1.05	1770	69.70	2055	80.90	910	35.80	2150	84.65	2473	97.30	1270	2797
<b>HC30-10M</b>	1.00	1.31	1830	72.00	2105	82.90	1060	41.70	2275	89.57	2617	103.00	1485	3274
<b>HC40-13M</b>	1.40	1.83	1975	77.70	2255	88.62	1200	47.24	2545	100.20	2891	113.82	1850	4093
<b>HC40-14M</b>	1.40	1.83	2035	79.80	2310	91.30	1200	47.20	2552	100.47	2922	115.04	1885	4149
<b>HC50-17M</b>	1.70	2.22	2227	87.60	2525	99.30	1200	53.00	2798	112.10	3284	129.30	2344	5114

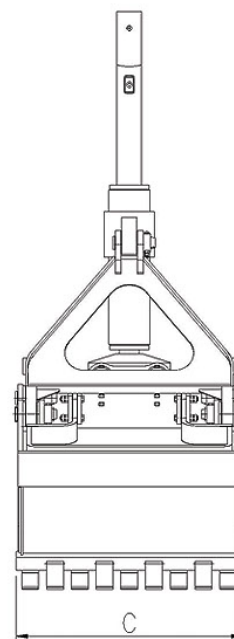
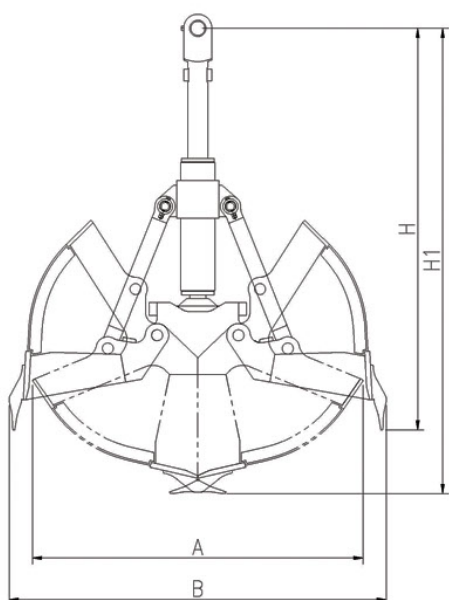

Sun and Shield

Application for Excavator

Excavator Attachment

Loader Attachment