

SNS LOADER PALLET FORK

Sun and Shield

Application for Excavator

Excavator Attachment



- Heat-treated and forged tines.
- Various tines are available.
- Low profile design for maximum visibility to tine tips.
- Designed for standard duty / pallet applications.
- Pallet forks are available as pin-on type or with SNS quick coupler system.

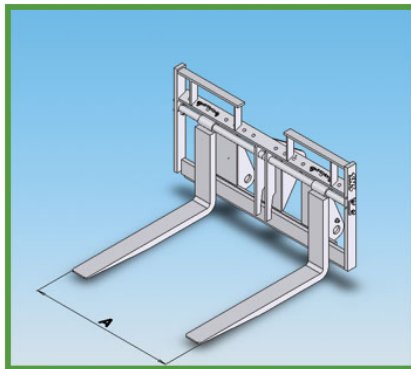

FORK

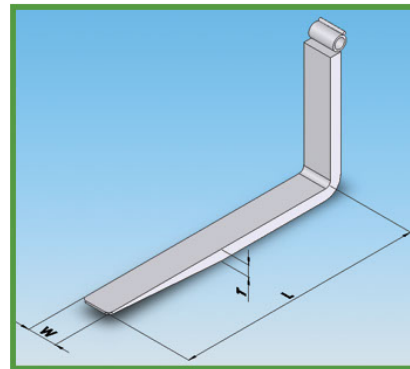

TINE

MODEL	W / LOADER	OPERATING WIDTH (A)	TINE SIZE			WEIGHT
			Length (L)	Width (W)	Thickness (T)	
PF201-48	8 - 10 tons	450-2030 mm (18-80 in)	1200 mm (48 in)	150 mm (5.9 in)	60 mm (2.4 in)	710 kg (1556 lb)
PF301-60	10 - 13 tons	450-2030 mm (18-80 in)	1500 mm (60 in)	150 mm (5.9 in)	60 mm (2.4 in)	750 kg (1651 lb)
PF501-72	13 - 17 tons	450-2030 mm (18-80 in)	1800 mm (72 in)	180 mm (7.1 in)	70 mm (2.8 in)	1225 kg (2700 lb)
PF601-72	17 - 22 tons	600-2160 mm (24-85 in)	1800 mm (72 in)	180 mm (7.1 in)	70 mm (2.8 in)	1280 kg (2822 lb)
PF701-72	22 - 27 tons	600-2160 mm (24-85 in)	1800 mm (72 in)	200 mm (7.9 in)	95 mm (3.7 in)	1910 kg (4215 lb)
PF801-72	27 - 35 tons	600-2160 mm (24-85 in)	1800 mm (72 in)	200 mm (7.9 in)	95 mm (3.7 in)	2200 kg (4852 lb)

Loader Attachment