

SYM	DATE	REVISION	EO NO.	DR	CK
△					
△					
△					

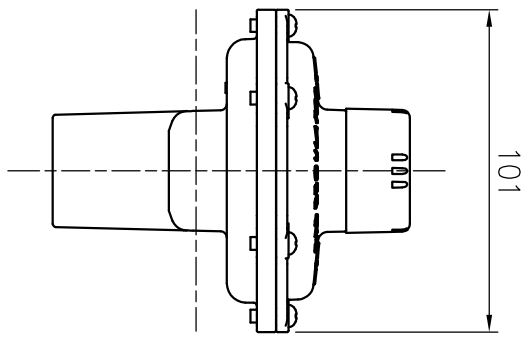

**SPECIFICATIONS**

MODEL	HYR-205L	
GAS	NATURAL GAS	
CAPACITY	5 m <sup>3</sup> /h	
MAX INLET PRESSURE	40 kPa	
SET OUTLET PRESSURE	2 kPa	
OPSO SET PRESSURE	-	
Internal Relief Working Pressure	-	
CONNECTION SIZE	INLET	PT 3/4"
	OUTLET	PT 3/4"

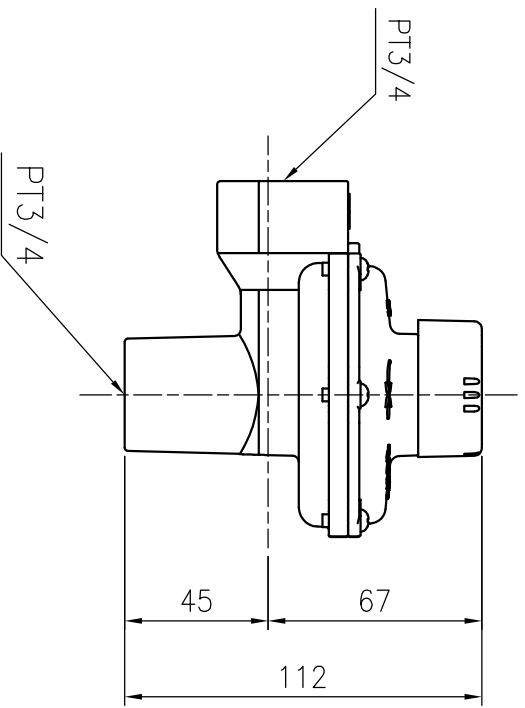
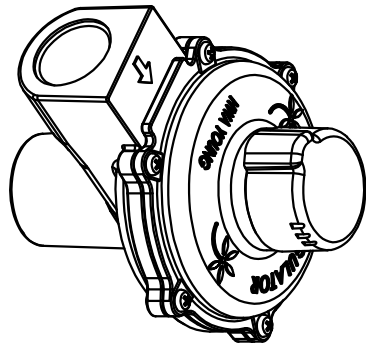
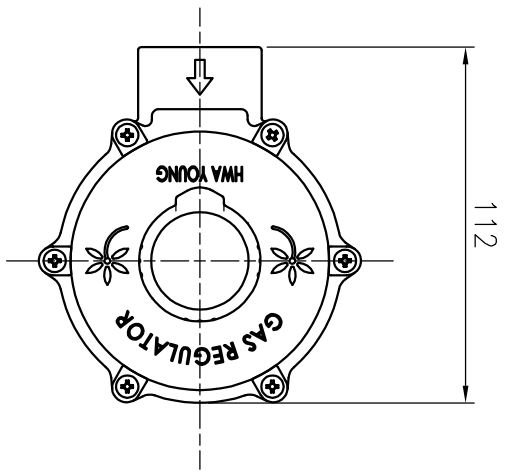

NO.	PART NO.	PART NAME	MAT'L	Q'TY	REMARK

DESIGN	CHECKED	APPROVED	DATE	PROJECTION
<i>Joe</i>	<i>X</i>	<i>[Signature]</i>	2016.10.11	3RD ANGLE
MODEL	HYR-205L LOW PRESSURE REGULATOR			SCALE
				N/S

PART NAME	Dimensions Drawing			MATERIAL	-	Q'TY	1
PART NO.	HMR005-1100-1	UNIT	mm	FORM	A4	SHT	1
						SHTS	1

SYM	DATE	REVISION	EO NO.	DR	CK

# HYR-205L LOW PRESSURE REGULATOR

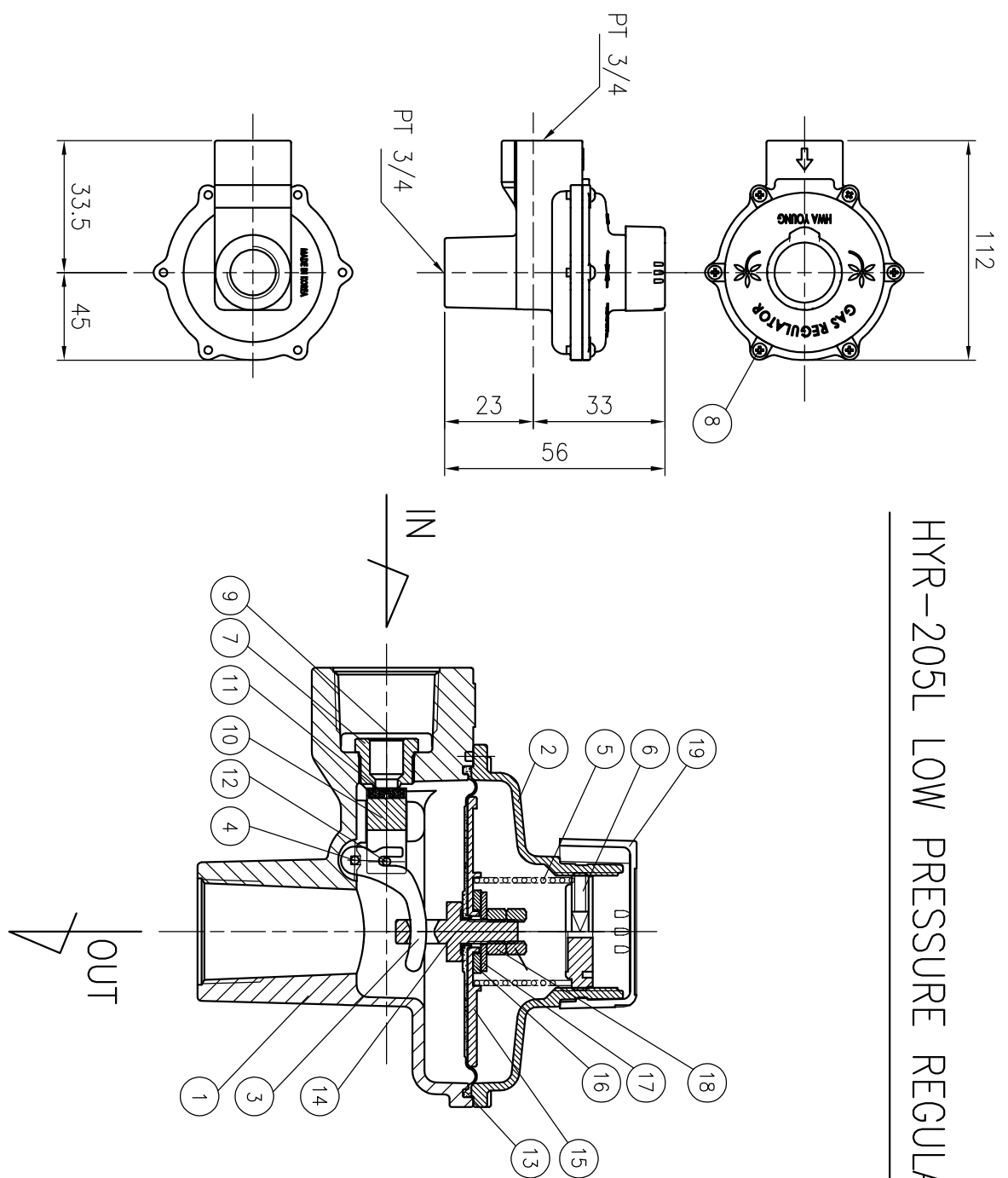

## SPECIFICATIONS

MODEL	HYR-205L	
GAS	NATURAL GAS	
CAPACITY	5 m <sup>3</sup> /h	
MAX INLET PRESSURE	40 kPa	
SET OUTLET PRESSURE	2 kPa	
OPSO SET PRESSURE	-	
Internal Relief Working Pressure	-	
CONNECTION SIZE	INLET	PT 3/4"
	OUTLET	PT 3/4"

19	HYR005-P022	GAP	ABS	1	
18	SJ00032	Nut	STSS304	2	
17	SJ00085	Washer	STSS304	1	
16	SJ00002	Washer	STEEL	1	
15	HYR004-P017	Dia-Plate	ACETAL	1	
14	HYR005-P020	Pole	ACETAL	1	
13	HYR004-R018	Diaphragm	NBR	1	
12	PN001-005	Spring Pin	STSS304	1	
11	HYR005-R039	Valve Seat	NBR	1	
10	HMR005-B002	Valve Stem	C3604	1	
9	HYR005-W031	Strainer	STSS304	1	
8	SJ000032	Bolt	S10C	6	
7	HMR005-B001	Nipple	C3604	1	
6	HYR004-P015	Adjusting Screw	ACETAL	1	
5	HMR005-W001	Adjusting Spring	STSS304	1	
4	HYR005-W008	Lever Pin	STSS304	1	
3	HMR005-C001	Lever	STEEL	1	
2	HYR005-A005	Cover	ALDC	1	
1	HMR005-A001	Body	ALDC	1	



DESIGN	CHECKED	APPROVED	DATE	PROJECTION
			2016.10.11	3RD ANGLE
MODEL	HYR-205L LOW PRESSURE REGULATOR			SCALE
				N/S
PART NAME	Assembly Drawing		MATERIAL	QTY
			-	1
PART NO.	HMR005-1100		UNIT	FORM
			mm	A3
				SHT 1
				SHTS 1