

Non-wetting
Dry Fog Humidifiers = AKIMist® "E" =
The world's most compact, high-powered humidifiers

AE-4(03C) or AE-4(03B)

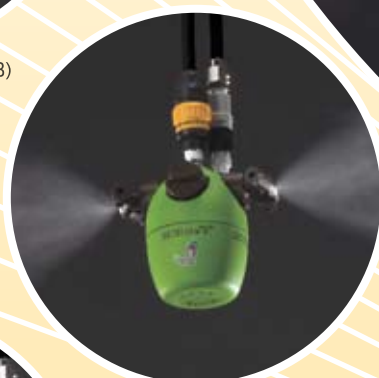

AE-3(03C) or AE-3(03B)



AE-2(03C) or AE-2(03B)



AE-1(03C) or AE-1(03B)



“The Fog Engineers”

H. IKEUCHI & CO., LTD.

Main Applications

- Humidification ■ Moisture Control ■ Static Electricity Prevention
- Preventing Dust Adhesion ■ Dust Suppression ■ Curing, etc.

Features

- Dry Fog is sprayed over 4 meters horizontally to provide widespread humidification. (*1)
- Up to 4 nozzles can be mounted per body.
- Compact water tank keeps free from bacteria.
- Automatic humidity control is available with timer or humidity controller.

(*1) Spray length depends on the surrounding air temperature and humidity conditions.

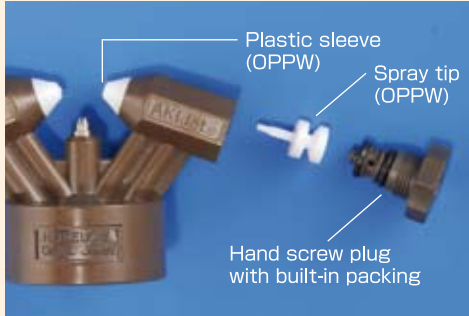

Compatible with AKIMist "D" body
(only nozzle can be replaced)

By utilizing AKIJet®, AKIMist®"E"(O3C type) sprays Dry Fog; highly-uniform droplet fog with mean diameter of less than 10µm*. It can humidify without wetting targets.
*AKIO3B nozzle has a mean droplet diameter of 12µm.

Easier to maintain and harder to clog

- Most clog-resistant nozzle created using new technology
- Plug and spray tip are combined, making it easier to disassemble and clean
- 20% less air consumption (compared to AKIMist® "D")

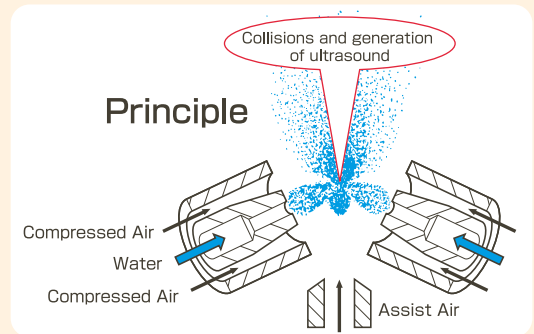

High quality, silky Dry Fog

O3C type

Sauter mean droplet diameter*: **7.5µm** *measured by a laser analyzer

Spray volume: **2.4ℓ/hr** at 0.3MPa
(per nozzle)

O3C type produces non-wetting Dry Fog (smoke-like ultrafine fog) of uniform quality with silky-touch. Suitable for humidification without wetting your machines and products even with a room of limited space.

■ O3C Nozzle Performance ■ (per nozzle)

Air Pressure MPa (psi)	Spray Volume ℓ/hr (GPH)	Air Consumption ℓ/min, Normal (SCFM)
0.2 (29)	1.3 (0.34)	22 (0.82)
0.3 (44)	2.4 (0.63)	29 (1.08)
0.4 (58)	3.1 (0.82)	36 (1.34)
0.5 (73)	3.6 (0.95)	43 (1.60)

Note: Use under the air pressure of between 0.2-0.5MPa (29-73psi)

■ Specifications ■ (per body)

Model No.	Number of Nozzles	at air pressure of 0.3MPa (44psi)	
		Spray Volume ℓ/hr (GPH)	Air Consumption ℓ/min, Normal (SCFM)
AE-1 (O3C)	1	2.4 (0.63)	29 (1.08)
AE-2 (O3C)	2	4.8 (1.27)	58 (2.16)
AE-3 (O3C)	3	7.2 (1.90)	87 (3.24)
AE-4 (O3C)	4	9.6 (2.54)	116 (4.32)

Sauter mean droplet diameter measured by a laser analyzer: 7.5 µm

Large volume fog

O3B type

Sauter mean droplet diameter*: **12µm** *measured by a laser analyzer

Spray volume: **3.3ℓ/hr** at 0.3MPa
(per nozzle)

Suitable for humidification in a spacious room requiring many humidifiers.

■ O3B Nozzle Performance ■ (per nozzle)

Air Pressure MPa (psi)	Spray Volume ℓ/hr (GPH)	Air Consumption ℓ/min, Normal (SCFM)
0.3 (44) 0.35 (51)	3.3 (0.87)	29 (1.08)

Note: Use under the air pressure of between 0.3-0.35MPa (44-51psi)

■ Specifications ■ (per body)

Model No.	Number of Nozzles	at air pressure of 0.3MPa (44psi)	
		Spray Volume ℓ/hr (GPH)	Air Consumption ℓ/min, Normal (SCFM)
AE-1 (O3B)	1	3.3 (0.87)	29 (1.08)
AE-2 (O3B)	2	6.6 (1.74)	58 (2.16)
AE-3 (O3B)	3	9.9 (2.61)	87 (3.24)
AE-4 (O3B)	4	13.2 (3.48)	116 (4.32)

Sauter mean droplet diameter measured by a laser analyzer: 12 µm

Spray Droplet Size by various humidifiers

The followings are pictures of droplets collected by Immersion Sampling and droplet diameter distribution measured by the laser analyzer.
(The vertical axis is for droplet diameter, and the horizontal for the proportional number of droplets.)

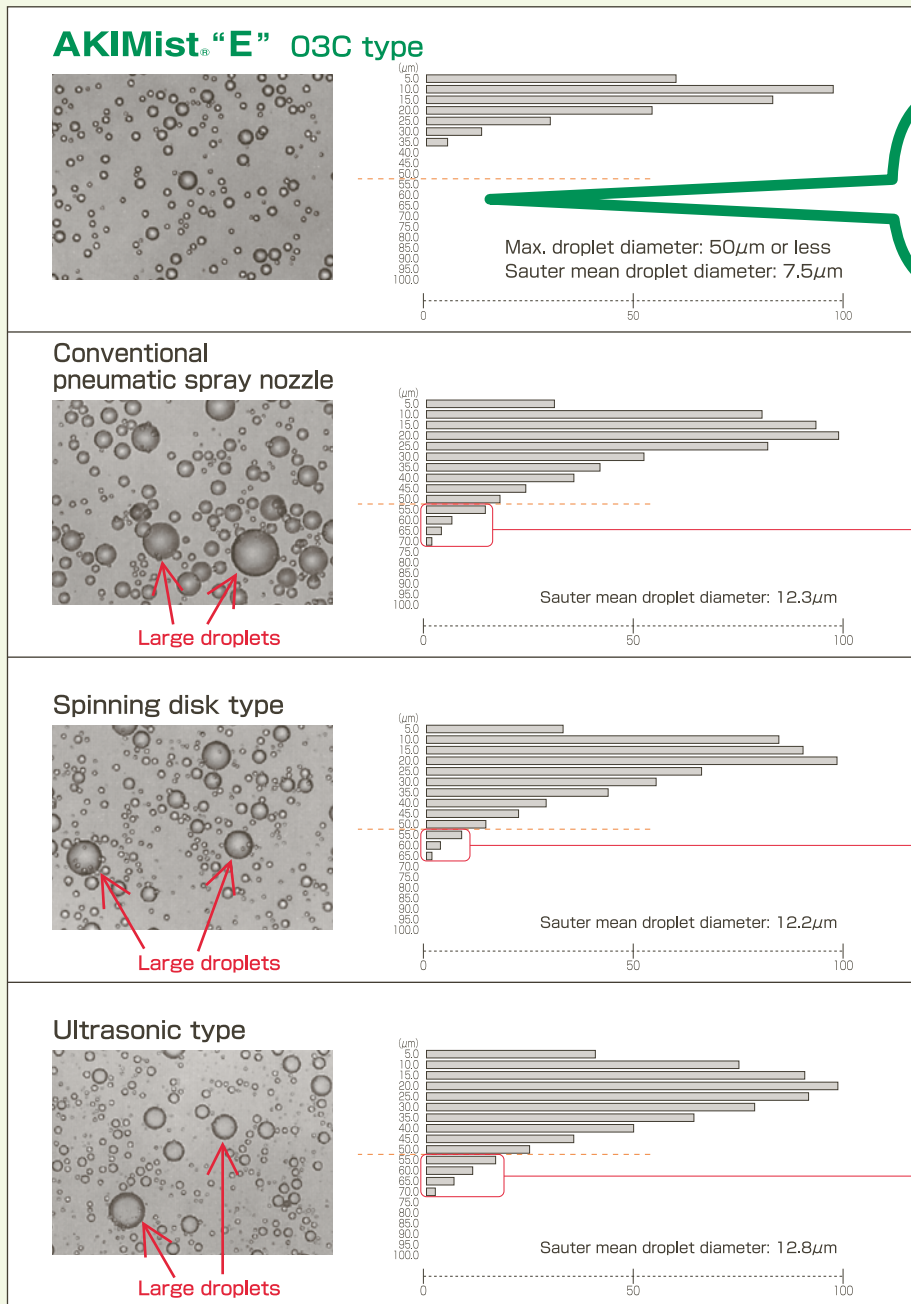

Uniform fog, having no large particles, humidifies effectively without getting anything wet.

Even though the mean droplet diameter is small, spray distributions including large droplets will eventually cause wetting.

Applications

- Humidification : Textile factory, Mushroom nursery, Poultry incubation, Fermentation room, Cold storage for food,
- Moisture control : Textile, Paper, Plywood, etc.
- Preventing dust adhesion : Plastic molding, Bag-making, Painting line, etc.
- Dust suppression : Painting line, Foundry, Ceramic fabrication, etc.
- Curing : Concrete, etc.
- ESD prevention / Static electricity control : Printing, Textile, Painting line, Plastic film, Plastic molding, Assembly line of electronics, Paper, etc.



AKIMist[®] "E" Dimensions

- Materials**
- Body : PP, S303 (Stainless steel 303)
 - Nozzle : PPS, OPFW, S303
 - Other parts: NBR, FKM (O-ring, Packing), etc.
- Mass**
- Approx. 340g (Loaded)

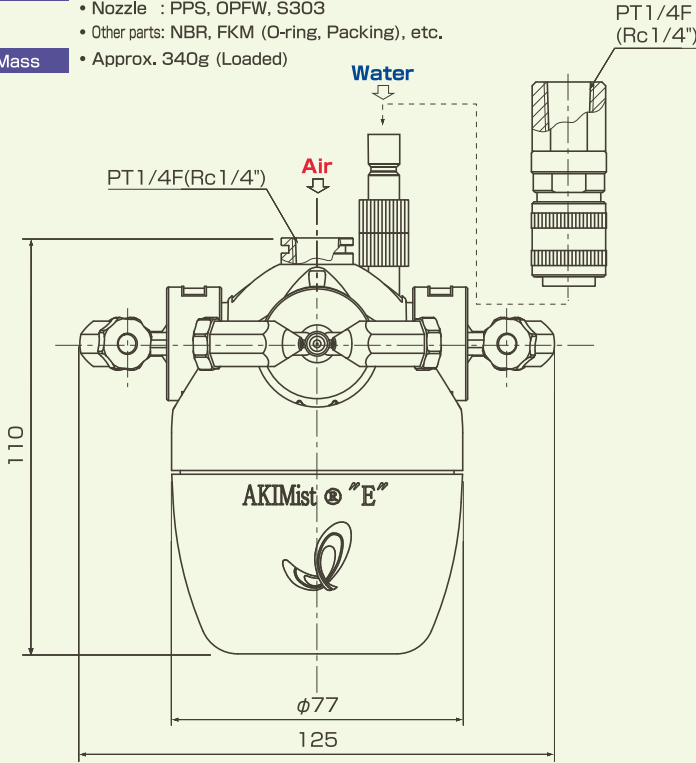

Note:

- Use at air pressures of between 0.2-0.5MPa (29-73psi) for O3C and between 0.3-0.35MPa (44-51psi) for O3B
- Use at water pressure of between 0.05-0.2MPa (8-29psi)
- Before disassembling, close the water valve.
- As main parts are made of plastic, handle AKIMist[®] "E" with care. (For details, see Instruction Manual.)

Optional product

AE-UT Adaptor for AKIMist[®] "E"



■ Aim Dry Fog to designated area



■ Intensive large volume spraying

- AE-UT Adaptor enables you to adjust spray direction as desired.
- You can easily attach and remove the AE-UT Adaptor by hand.

Note: Stop spraying when you change the direction

Pipe Connection Kits (optional) for easy installation of AKIMist[®] "E"

Wall mounting kit and Hanging-down kit are assembled before shipment.

Standard Kit

Hanging-down (NP) Kit (w/o plate)

Wall Mounting Kit

Hanging-down Kit

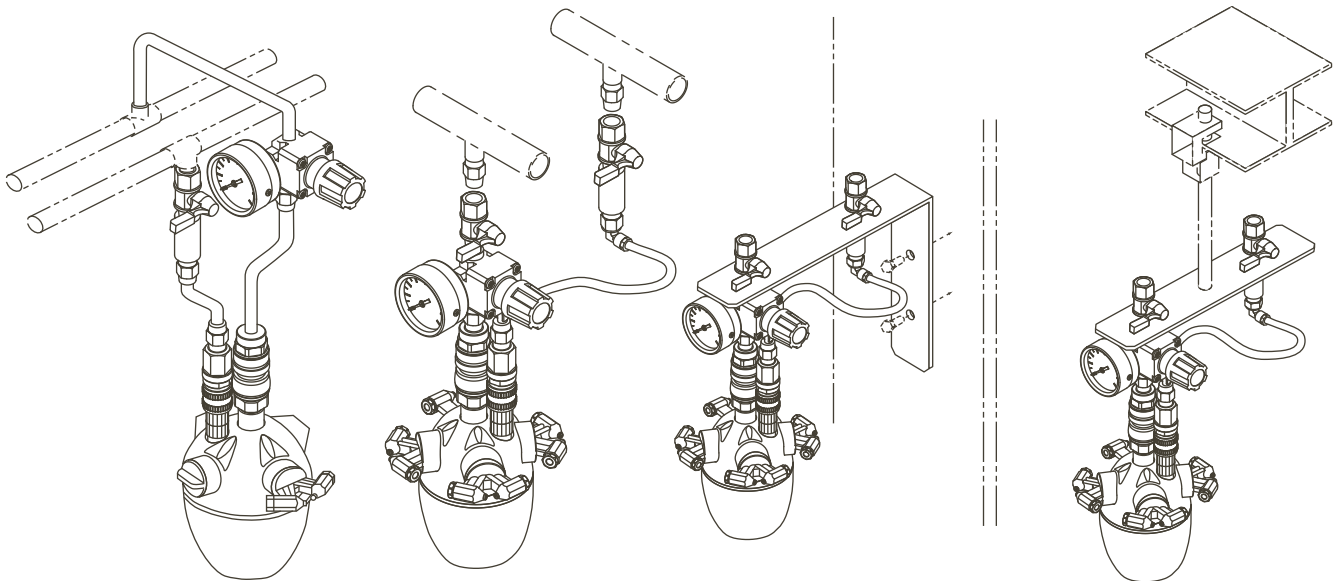

- This Kit is to be assembled by customers.
- 1/4" PT male (Rc 1/4") threaded connection.

- 1/4"PT female (Rc1/4") threaded connection.

- Bolts for fixing mounting plate are not included and to be prepared by customers.
- The diameters of holes on the plate are 9mm.
- 1/4" PT female (Rc 1/4") threaded connection.

- Bolts & hanging fixture are not included and to be prepared by customers.
- The diameter of hole on the plate is 11mm.
- 1/4" PT female (Rc 1/4") threaded connection.

Installation & Ancillary Devices

For minimal maintenance and long life, clean air and purified water must be supplied. IKEUCHI, with a wealth of experience, provides a wide range of ancillary devices for purifying water/air and automatic humidity control.

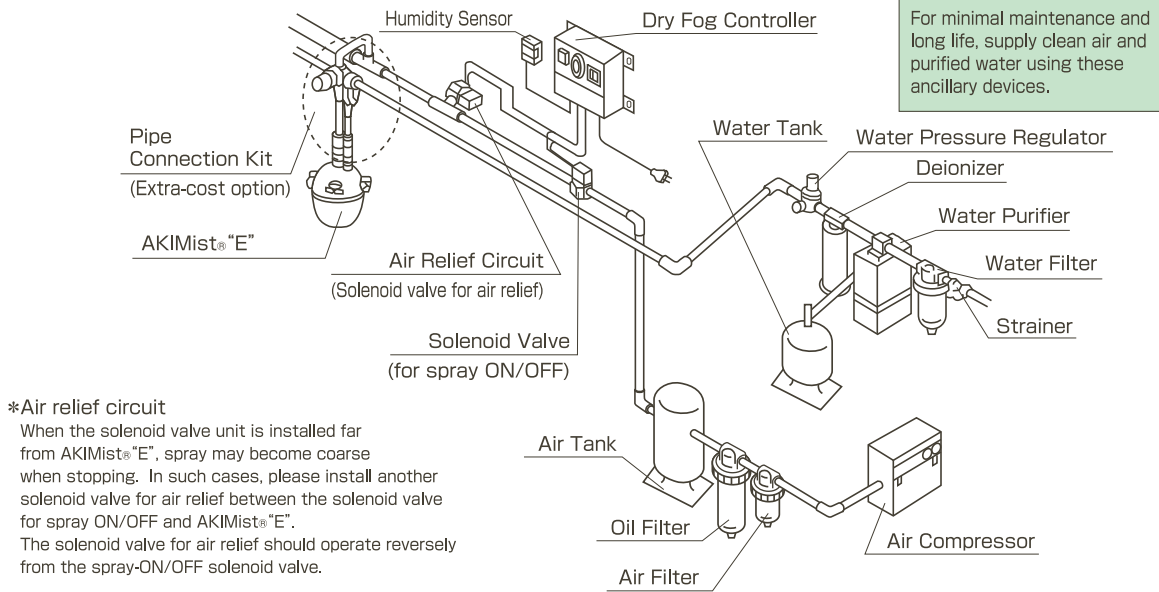

Air compressor selection chart

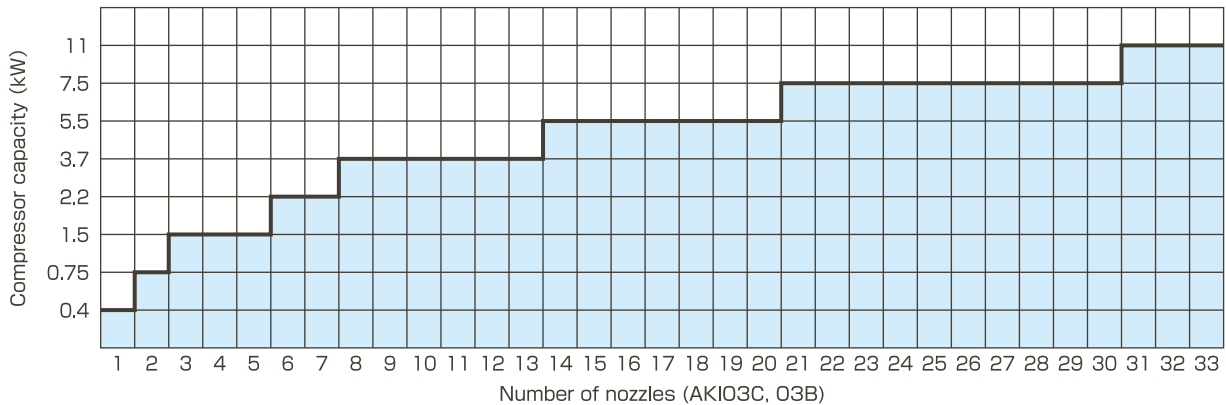

- Notes: 1. Reference for when spraying at 0.3MPa air pressure.
2. Type of compressor: reciprocating compressor for 0.4-7.5kW and a screw compressor for 11kW.
3. Using this chart as a target, consult your compressor catalog and confirm the output capacity.

How to select Air and Water Purifying Devices

The number of AKIO3C nozzles		1	2	3	4	5	6	7	8	9	10	11	12	13	14	15	16	17	18	19	20	21	22	23	24	25	26	27	28	29	30	31	32	33
Air consumption	ℓ/min, Normal (SCFM)	29ℓ/min, Normal (1.08SCFM) × the number of nozzles																																
Water consumption	ℓ/hr (GPH)	2.4ℓ/hr (0.63GPH) × the number of nozzles																																
Recommended pipe size (Stainless steel pipes should be used)	Air	1/4"PT or over			3/8"PT or over			1/2"PT or over						3/4"PT or over																				
	Water	1/4"PT or over			3/8"PT or over						1/2"PT or over																							

If you plan to use AKIO3B nozzles, please inquire with us.

For minimal maintenance and long life, supply Clean Air and Pure Water

	Air	Water
Pressure	0.2-0.5MPa (29-73psi) for O3C 0.3-0.35MPa (44-51psi) for O3B at point of use	0.1MPa (15psi) at point of use
Temperature	5 °C (41 °F) ~Room temperature	Room temperature
Quality	Air without moisture, oil mist and dust; Dew point 10 °C.	No particles Electric Conductivity = 0.07-10 micro-S/cm (Resistance 14 - 0.1 M ohm/cm)

Ancillary Devices

Humidity Controller (RHC-031D) Digital type



- Digital display of present humidity and target humidity
- Compact size to fit any place
- Measurement accuracy: $\pm 3\%$ (over the range 20-80%RH)
- Supply voltage: 100V-240V
- Range of operation 0-95%RH

Humidity Controller (RHC-D**A)



- Digital display of present humidity and target humidity
- Measurement accuracy: $\pm 3\%$
- Supply voltage: 100V-110V or 200V-240V
- Using a single controller, up to 4 zones spread over a wide area can be controlled individually.

Solenoid Valve Unit



A solenoid valve and reducing valve are bundled together as a unit for pressure relief. When the humidifier stops spraying, the remaining air pressure in the piping is instantly relieved, so that only fine fog is sprayed.

Air Filter

- For removal of dust and moisture contents over $0.03\mu\text{m}$ from the compressed air with micro-fiber.
- Available in a variety of sizes
- Air ancillary device sets include air filters and oil filters with a manual and automatic discharging drain and nipples.



Water Filter

- For removal of foreign particles over $5\mu\text{m}$.
- Available in a variety of sizes
- Water ancillary device sets include a water filter, a pressure regulator and nipples.



Benefits of Humidification

1. Static Charge Prevention

- Relation between humidity and static charge

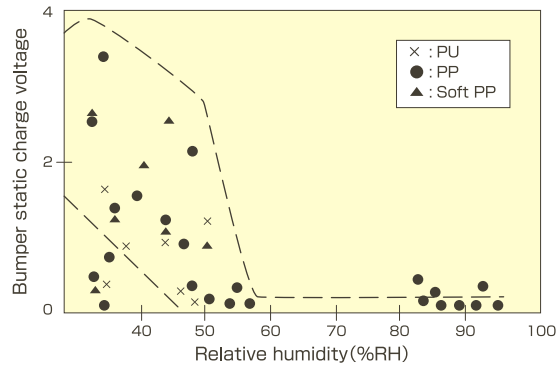

Helps to **eliminate static electricity problems**, improve product quality and reduce the number of defects.

2. Energy-Saving Effect

- Humidification and cooling effects

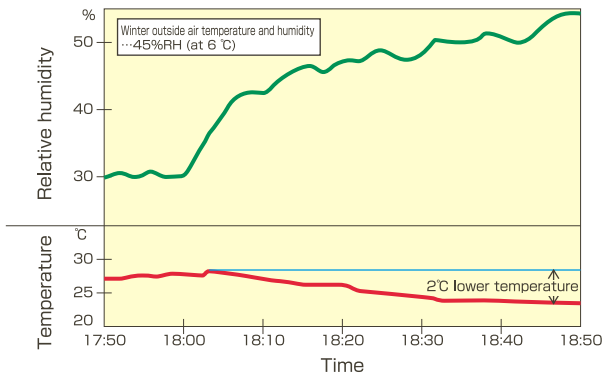

AKIMist[®] reduces the air temperature while humidifying. There is approximately a 2°C reduction in temperature.

- Comparison of the running cost of humidification methods

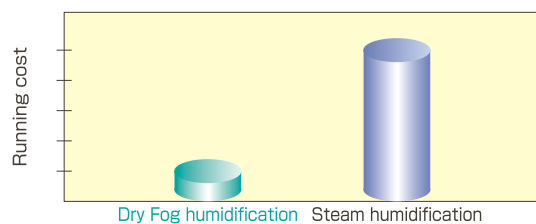

Energy cost for Dry Fog humidification is **only 1/5** of that for steam humidification.

3. Maintaining Operators' Health

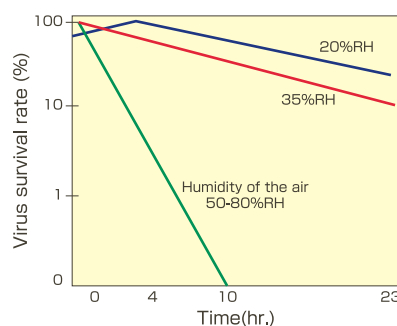

In an ambient of over 50% humidity, the influenza virus dies off within approximately 10 hours.

Customer Case Studies



1. Printing

Web Offset Printing Process

Humidity control suited to each printing press type and process has a big impact.

- AKIMist® has quickly gained acceptance as nozzle-type humidification systems are becoming popular in the printing industry.
- AKIMist® has the best track record in the Japanese printing industry, with over 20 years of strong experience.
- For sheet-fed printing, UV printing, Flexo printing and others, we have the best-suited solutions for all kinds of printing presses.

Improved productivity and quality, reduced waste paper

Paper jams, poor folds, etc. ➔ *Solved by controlling humidity to around 50%RH*



2. Electronics

SMT Process

A humidification method that can be counted on to save energy has become the strongest focus of attention.

- By maintaining humidity at an appropriate level, it is possible to prevent the various problems from static electricity.
- The dry fog cooling effect reduces the building cooling load.
- With the No. 1 track record as well as 15 years of remarkably good results, we have optimal solutions for a wide range of processes and environments.
- It is also well-suited for clean room humidification.

**Adhesion error rate reduced 60%
Cooling load reduced 20%**

Internal part damage ➔ *Solved by controlling humidity to around 45%RH*

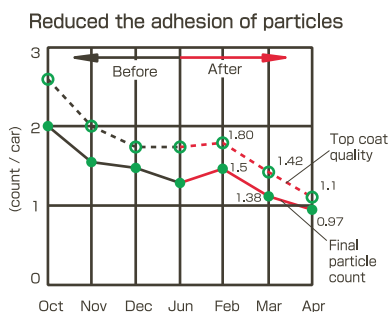

3. Painting

Painting Process for Cars

Control ambient humidity to eliminate static electricity and limit airborne waste.

- By keeping appropriate humidity, dust is suppressed and static electricity is reduced.
- Humidification is the first step to reduce the adhesion of dust to products.
- Starting with the car industry, AKIMist® is now used in many kinds of industry as the solution for dust problems.
- We can find solutions to meet the needs of your factory.

**Reduced the adhesion of dust by 20%
Maintaining Operators' health**

Defective painting by adhesion of dust etc. ➔ *Solved by controlling humidity to about 50% RH*

Other Installations

Field

Goal

Concrete examples of results

Textiles

Improved productivity

- Thread breakage is prevented and productivity improved.
- Prevented pass weft from sticking.
- Prevented defects due to static electricity.

Chemicals

Safety precautions

- Reduced the risk of ignition in paint and ink mixing processes.
- Allowed humidification for processes where it had been previously thought impossible.
- Reduced risk of fire, which could lead to loss of life and loss of public trust.

We have numerous proven solutions for industries beyond the above cases. *These effects depend on factory conditions.

Accurate and easy

AKIMist®"E" KIT

Dry Fog Humidifier Kit

AE-KIT

All the components for an efficient humidification system in an easy DIY kit. Just supply the electricity and compressed air.

- You can choose the contents of AE-KIT freely to suit your factory size and layout.
- Includes piping and connectors for tap water and air, you can install them easily, and keep optimal humidity. (AKIMist®"E" is installed on a wall.)
- One AE-KIT is good for spaces of up to 800m³
*Please contact us for an inquiry sheet.

Includes:

Nozzle unit (AKIMist®"E"), Control unit, Water (filter) unit and Piping unit. You can install AE-KIT easily, and be controlling humidity soon.

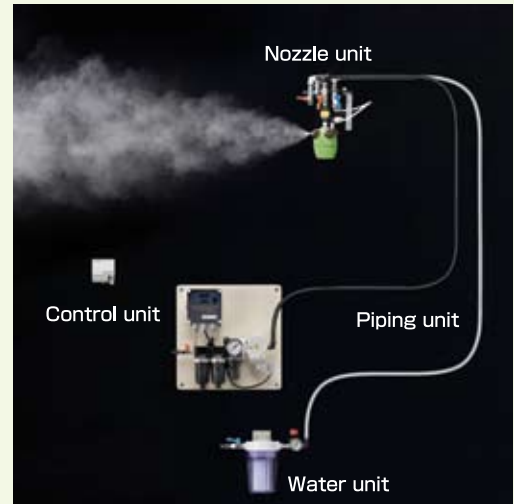

No piping work!

AKIMist®"E" Portable Dry Fog Humidifier Set

AE-T set

No piping work necessary. Easy, convenient humidification. Portable humidifier set for immediate usage in any place with an air supply.

- AKIMist®"E" portable humidifier set with a stand unit and pressure tank.
- No installation work required.
- Easy automatic control with a humidity controller (optional).

Main Applications

- Spot humidification around machinery and electrostatic prevention.
- Humidification in factories such as electronics, printing, textile, paper mills, etc.

A Ranges of Options

- ① Choose your fog — two types of spray nozzles are available; O3C-type for high quality fog (2.4ℓ/hr or 0.63GPH)* and O3B-type for large volume fog (3.3ℓ/hr or 0.87GPH)*.
*Spray volume per nozzle at air pressure of 0.3MPa.
- ② Up to 4 nozzles can be mounted. A humidifier with 4 nozzles has large spraying capacity, maximum 13.2ℓ/hr (3.48GPH) at air pressure of 0.3MPa (44psi).
- ③ Automatic humidity controller set is available as an optional extra. Please specify it at the time of order.

Includes:

AKIMist®"E", Stand with wheels, Telescopic pole, Pressure tank, Gauge-mounted pressure regulators, Mounting unit

Option Compact humidity controller set

< Water pressure tank >

Capacity of tank	Material	Max. pressure	Mass
18ℓ (4.8gal)	Stainless steel 304 etc.	0.7MPa (100psi)	5kg (loaded: 23kg) 11lb (loaded: 50.7lb)

Note: Safety valve is set at 0.4MPa.



"The Fog Engineers"

H. IKEUCHI & Co., LTD.

ISO9001:2008 certified



Headquarters

Daiichi Kyogyo Bldg., 1-15-15 Awaza
 Nishi-ku, Osaka 550-0011, Japan
 Tel: 81-6-6538-4015 Fax: 81-6-6538-4022
 E-mail: overseas@kirinoikeuchi.co.jp
 URL: <http://www.kirinoikeuchi.co.jp/eng/>

IKEUCHI (SHANGHAI) CO., LTD.

Room 1311, Building A North Region Commercial Plaza, 988 Da Tong Road, Zha Bei District Shanghai 200070, P.R.China
 Tel: 86-21-6140-9731 Fax: 86-21-6123-4239 E-mail: mist@kirinoikeuchi.com URL: www.kirinoikeuchi.com/

IKEUCHI USA, INC.

8110 Beckett Center Drive, West Chester, OH 45069, USA
 Tel: 1-513-942-3060 Fax: 1-513-942-3064 E-mail: info@ikeuchiusa.com URL: www.ikeuchiusa.com/

IKEUCHI EUROPE B.V.

Asterweg 17 A6, 1031 HL Amsterdam, The Netherlands
 Tel: 31-20-820-2175 Fax: 31-20-820-2176 E-mail: info@ikeuchieurope.com URL: www.ikeuchieurope.com/

Ikeuchi Taiwan Co., Ltd.

11F-1, No. 27, Sec. 1, Chung Shan N. Rd., Taipei, 10441, Taiwan R.O.C.
 Tel: 886-2-2511-6289 Fax: 886-2-2541-6392 E-mail: sales@ikeuchi.com.tw URL: www.ikeuchi.com.tw/

IKEUCHI (THAILAND) CO., LTD.

12 Soi Chalermprakiat Rama 9, Soi 30 Yak 24, Kwang Dokmai, Khet Prawet, Bangkok 10250 Thailand
 Tel: 66-2-328-0392 Fax: 66-2-328-0391 E-mail: info@ikeuchithai.com