

Product Features

- limited type anti-vibration mount.
- This product can be used when the operation weight of equipment shall be increased and different from stop weight.
- Adjusting optimized height level.
- Easy to adjust level by control bolt.
- Attached Neoprene Pad in order to avoid structure borne-noise transmission.
- One side of Neoprene Pad is cut for drain to prevent product corrosion.

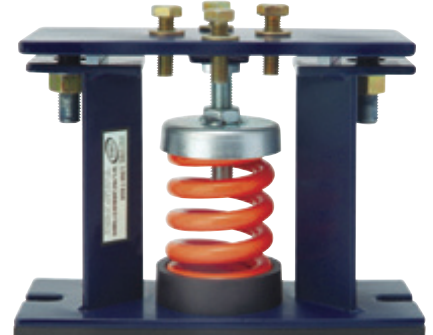

Product Configuration

- Upper part steel plate
- Temporary strut
- Control bolt
- Upper part spring cap
- Coil spring
- Lower part spring cap
- Lower part steel plate
- Neoprene Pad

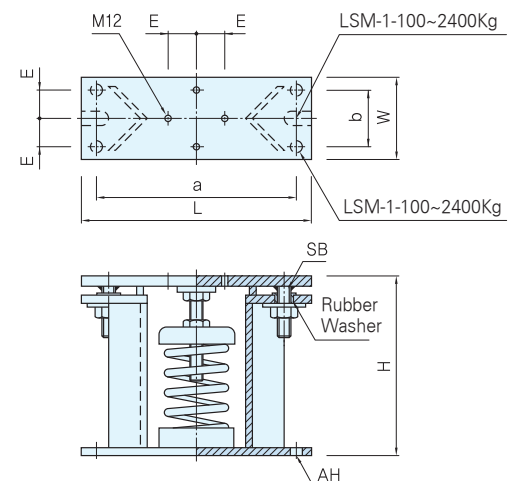

Product Usage

- Refrigerator, Cooling tower
- Generator
- Anti-vibration of heavy weight vibrator etc
- Anti-vibration for vibrator without strut

Product Specification

Model	Rated Cap (kgf)	Rated Def (mm)	Mount Constant [kgf/mm]	Spring			Dimension [mm]								
				Color Code	OD	HT	L	W	H	a	b	Ah	SB	E	Adjustment Bolt
LSM-1-100	100	25	4.0	Gray	73	105	258	100	180	228	-	Ø15	M16	35	M16 x 80L
LSM-1-200	200	25	8.0	White											
LSM-1-350	350	25	14.0	Blue											
LSM-1-500	500	25	20.0	Green											
LSM-1-600	600	25	24.0	Orange											
LSM-1-750	750	25	30.0	Black											
LSM-1-1000	1000	25	40.0	Yellow											
LSM-1-1200	1200	25	48.0	Red											
LSM-1-1500	1500	25	60.0	Black	73	105	378	100	180	340	-	Ø15	M16	35	M16 x 80L
LSM-1-2000	2000	25	80.0	Yellow											
LSM-1-2400	2400	25	96.0	Red											
LSM-1-3000	3000	25	120.0	Black	73	105	378	148	180	340	70	Ø15	M16	35	M20 x 80L
LSM-1-4000	4000	25	160.0	Yellow											
LSM-1-4800	4800	25	192.0	Red											

※ LSM-1-100~2400 : Anchor hole 2EA, LSM-1-3000~4800 : Anchor hole 4EA

※ Shape and specifications of the products can be changed without prior notice for quality and performance improvement.