

SSH-A1

Rated Deflection : 25mm
SEISMIC SPRING HANGER

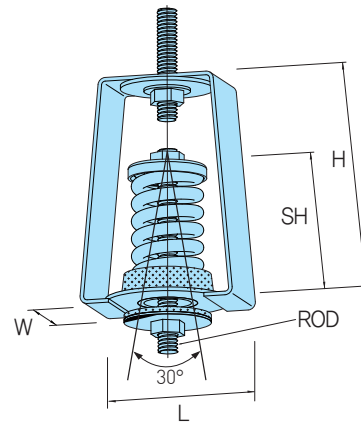
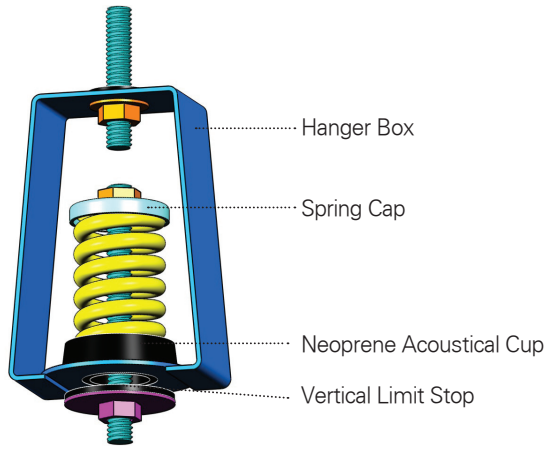

Product Features

- Hanger rod can move 30 degree as shown.
- The washer consisted of neoprene and steel is installed under hanger box to restrain vertical displacement when earthquake occurs. (Vertical limit stop)
- Heavy-duty design withstand more than 1.0G of accelerated force in load direction.

Product Usage

- Duct, Pipe, Suspended mount system
- Equipment to occur the vibration such as AHU equipment, Air blows etc

Applications

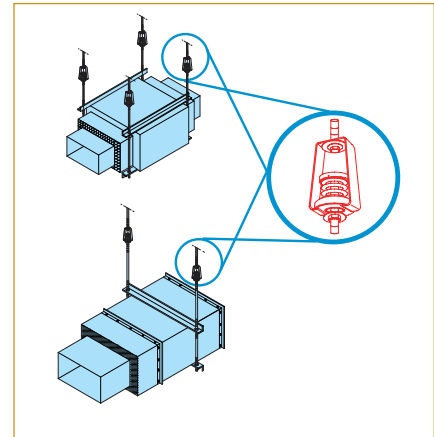

Product Specification

| Model | Rated Cap. (kgf) | Reted Def. (mm) | Spring Constant [kgf/mm] | Spring | | | Dimension [mm] | | | | | |
|-------------|------------------|-----------------|--------------------------|--------|----|-----|----------------|----|-----|-----|-----|-----|
| | | | | Color | OD | HT | L | W | H | SH | ROD | |
| SSH-A1-10 | 10 | 25 | 0.4 | Gray | 60 | | | | | | | |
| SSH-A1-25 | 25 | 25 | 1.0 | Orange | 60 | | | | | | | |
| SSH-A1-50 | 50 | 25 | 2.0 | Red | 60 | 80 | 125 | 64 | 178 | 115 | | M12 |
| SSH-A1-100 | 100 | 25 | 4.0 | Blue | 60 | | | | | | | |
| SSH-A1-150 | 150 | 25 | 6.0 | Brown | 95 | 112 | | | | | | |
| SSH-A1-200 | 200 | 25 | 8.0 | White | 95 | 100 | 160 | 75 | 194 | 134 | | M12 |
| SSH-A1-300 | 300 | 25 | 12.0 | Orange | 95 | 114 | | | | | | |
| SSH-A1-400 | 400 | 25 | 16.0 | Blue | 95 | | | | | | | M12 |
| SSH-A1-500 | 500 | 25 | 20.0 | Green | 95 | 122 | 160 | 75 | 209 | 142 | | M16 |
| SSH-A1-600 | 600 | 25 | 24.0 | Orange | 95 | | | | | | | M16 |
| SSH-A1-750 | 750 | 25 | 30.0 | Black | 95 | | | | | | | M16 |
| SSH-A1-1000 | 1000 | 25 | 40.0 | Yellow | 95 | 138 | 160 | 75 | 225 | 158 | | M20 |

※ Shape and specifications of the products can be changed without prior notice for quality and performance improvement.