

High-quality High-performance **WON** Linear Motion Guide

WON ST Linear Motion Guide is a four-row circular face-to-face duplex structure and a 4-direction equal load type which is excellent in bearing high load with high rigidity as well as compatibility between a rail and a block, and allows smooth and precise operation.

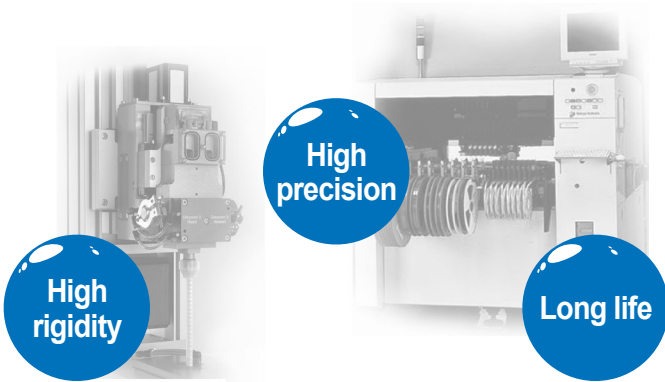

WON

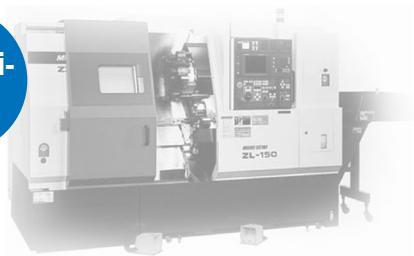
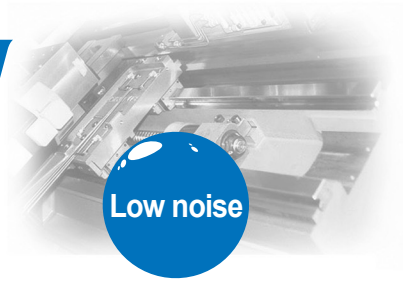

Linear Motion Guide - H series

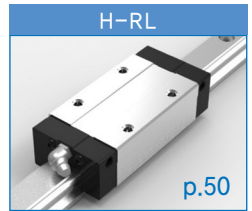
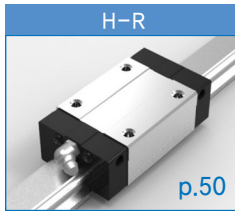
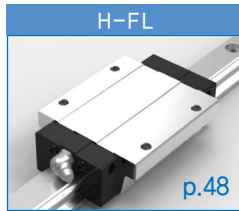
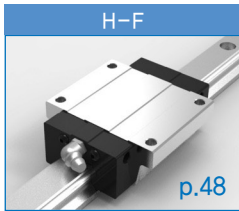

Slim Linear Motion Guide - S series

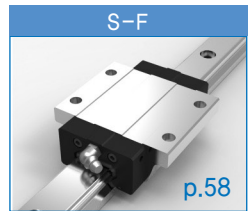
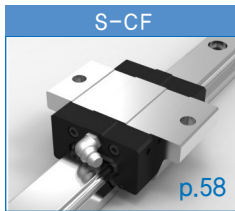
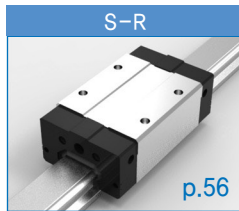
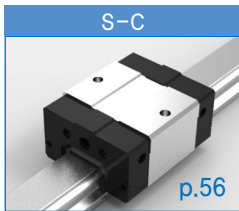

Miniature Linear Motion Guide - M series

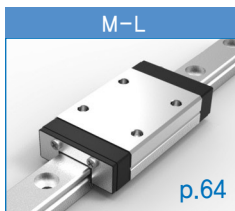
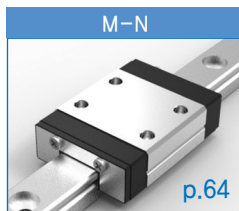
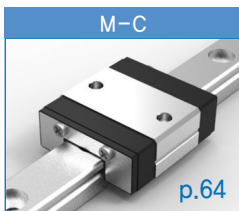

Miniature Wide Linear Motion Guide - MB series

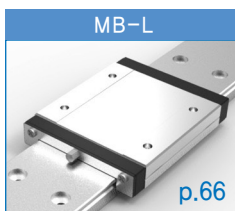
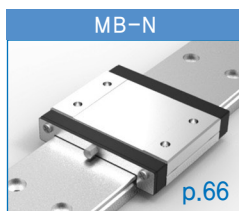
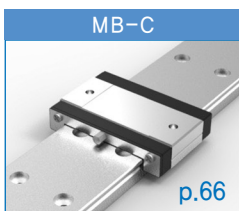

Linear Motion Roller Guide - R series

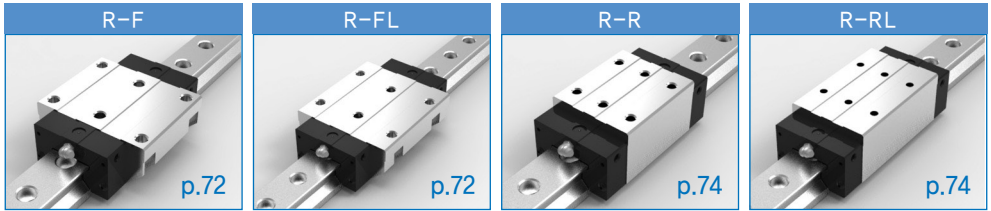

Linear Motion Guide Rail

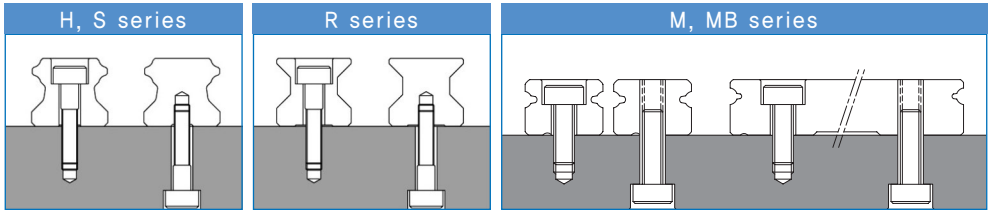

Crossed Roller Bearing

CB

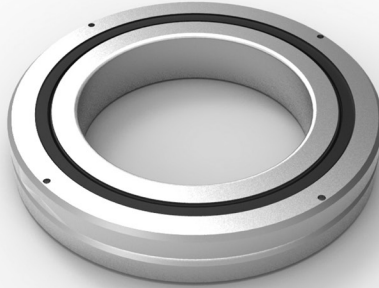

p.89

CH

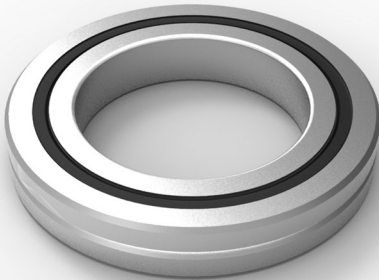

p.89

CS

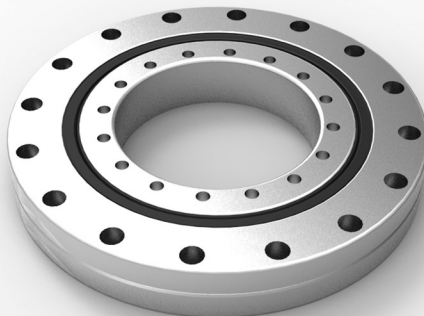

p.89



Compact Ball Spline

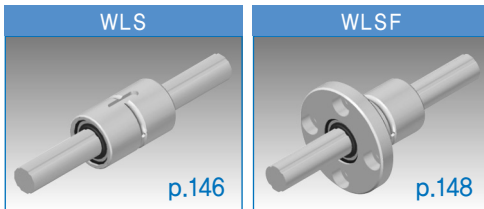

Linear Ball Spline

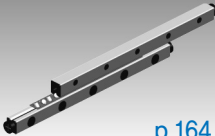
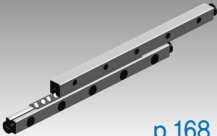

Cross Roller Guide Way

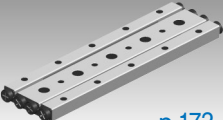
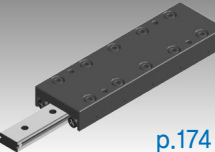
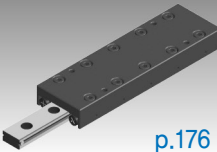
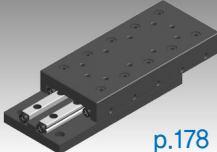
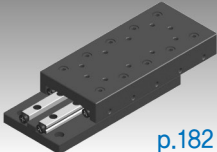
<p>WRG</p>  <p>p.164</p>	<p>WRGO</p>  <p>p.168</p>	<p>WRG-AC</p>  <p>p.170</p>	<p>WRGW</p>  <p>p.172</p>
<p>WRGT</p>  <p>p.174</p>	<p>WRGT-B</p>  <p>p.176</p>	<p>WRGU</p>  <p>p.178</p>	<p>WRGU-AC</p>  <p>p.182</p>

Super Ball Bushing – Asia series

SB Bearing

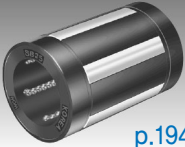

p.194

SBO Bearing

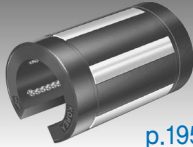

p.195

SH Block

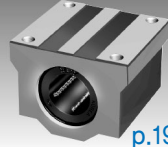

p.196

SHW Block

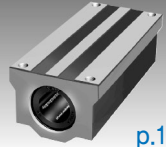

p.197

SH-A Block

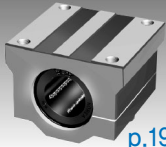

p.198

SHO Block



p.199

Super Ball Bushing – Europe series

SBE Bearing

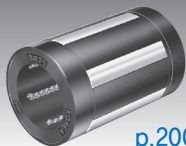

p.200

SBE0 Bearing

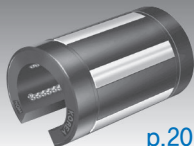

p.201

CS Bearing



p.202

CS-A Bearing



p.203

CSW Block

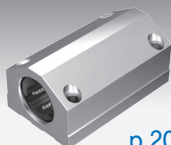

p.204

CSW-A Block

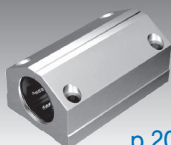

p.205

CSO Block



p.206

CSO-A Block



p.207

CSOW Block

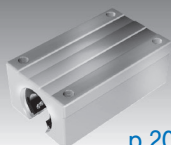

p.208

CSOW-A Block

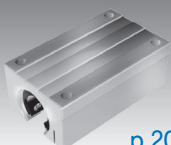

p.209

Super Ball Bushing – Inch series

SBA Bearing

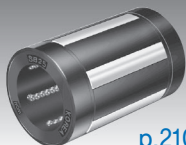

p.210

SBA0 Bearing

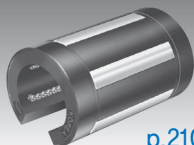

p.210

Linear Ball Bushing – Asia series

<p>LM</p>  <p>p.228</p>	<p>LM□OP</p>  <p>p.228</p>	<p>LM□AJ</p>  <p>p.228</p>	<p>LMF</p>  <p>p.232</p>
<p>LMK</p>  <p>p.232</p>	<p>LMH</p>  <p>p.232</p>	<p>LMF□L</p>  <p>p.234</p>	<p>LMK□L</p>  <p>p.234</p>
<p>LM□L</p>  <p>p.236</p>	<p>SC</p>  <p>p.237</p>	<p>SCWN</p>  <p>p.238</p>	

Linear Ball Bushing – Europe series

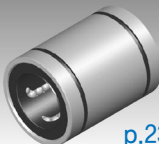
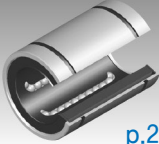
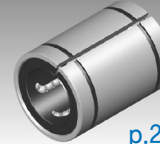
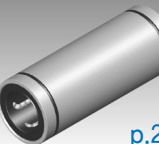
<p>LME</p>  <p>p.230</p>	<p>LME□OP</p>  <p>p.230</p>	<p>LME□AJ</p>  <p>p.230</p>	<p>LME□L</p>  <p>p.236</p>
---	--	--	---

Linear Motion Shaft

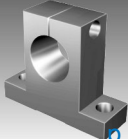
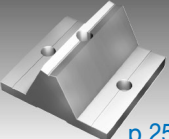
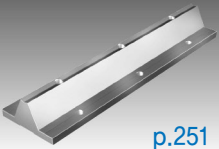
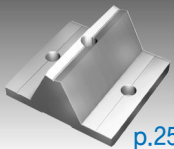
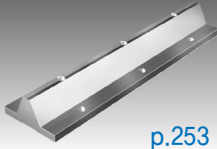
<p>STANDARD SHAFT</p>  <p>p.243</p>	<p>HOLLOW SHAFT</p>  <p>p.243</p>	<p>WK</p>  <p>p.249</p>	<p>S-ST</p>  <p>p.250</p>
<p>ST</p>  <p>p.251</p>	<p>S-STU</p>  <p>p.252</p>	<p>STU</p>  <p>p.253</p>	<p>Slide Rail Unit</p>  <p>p.254</p>

Track Roller Guide – outside type

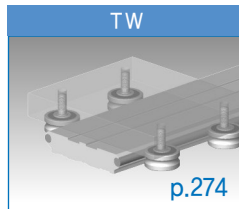
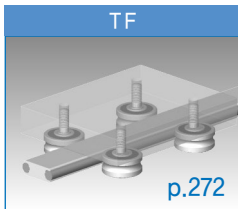
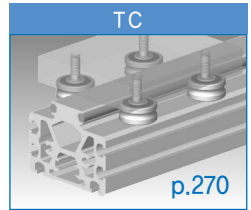
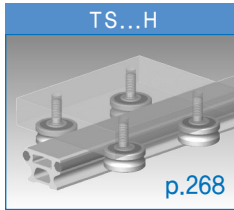
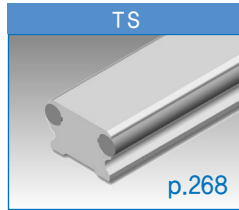
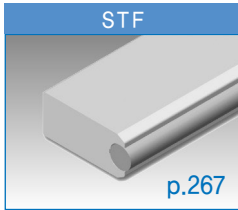

Track Roller Guide – inside type

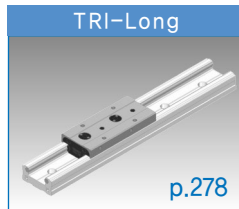
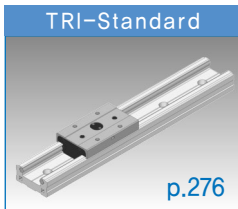

Linear Motion Guide

Contents

1	Linear Motion Guide	
	1. Characteristics	2
	2. Strengths	2
	3. Types	3
2	Selection of Linear Motion Guide	
	1. Overview	4
	2. Procedure	4
3	Life Calculation	
	1. Load rating and life	5
	2. Load calculation	6
	3. Service condition setting	6
	4. Load calculation formula	7
	5. Equivalent load calculation	11
	6. Equivalent load calculation formula	11
	7. Static safety factor calculation	12
	8. Mean load calculation	13
	9. Rating life calculation	14
4	Rigidity & Preload	
	1. Preload	16
	2. Radial clearance	17
5	Friction	
	1. Friction	19
	2. Friction coefficient	19
6	Precision	
	1. Precision specification	20
	2. Precision design	20
	3. Dimension Tolerance and Difference	20
	4. Selection of Precision Class	24
7	Lubrication	
	1. Purpose	26
	2. Selection of lubricant	26
	3. Grease lubrication	26
	4. Oil lubrication	27
8	Surface Treatment	
	1. Surface treatment	28
	2. Types of Surface Treatment	28
9	Dust Proof	
	1. Dust proof	28
	2. Types of dust proof	28
10	Measure to Use in Special Environment ...	29
11	Placement & Installation	
	1. Placement and structure	30
	2. Mounting and fixation	31
	3. Design of mounting surface during installation	32
	4. Error tolerance of mounting surface during	34
	5. Marking of datum plane during installation	37
	6. Connection of rails	37
	7. Torque used to fasten bolts during the assembly of LM guide	38
	8. Torque used to fasten bolts during the assembly of LM guide	42
	9. Directions of bolt fastening by LM guide type	43
12	Types of LM Guide	
	1. LM Guide H Series	44
	2. Slim LM Guide S Series	52
	5. Miniature LM Guide M Series	60
	6. Wide Miniature LM Guide MB Series	60
	7. LM Roller Guide R Series	68
13	Options	
	1. Seal and rail cap	76
	2. Oil filler	78
	3. Grease nipple	79
	4. Support rail-enabled mounting	79
	5. How to install LM guide using a support rail	80
14	Instructions for Handling	
	1. Handling	81
	2. Lubrication	81
	3. Caution for use	81
	4. Storage	81

Crossed Roller Bearing

Contents

1	Structure and characteristic of Crossed Roller Bearing	
1.	Structure.....	88
2.	Characteristics.....	88
3.	Use.....	88
2	Kind of Crossed Roller Bearing	
1.	CB series of revolving inner ring	89
2.	CH series for high stiffness	89
3.	CS series for customized special type	90
3	Selection of Crossed Roller Bearing	
1.	Selection summary.....	91
2.	Selection sequence.....	91
4	Nominal numbering	92
5	Calculation of service life	
1.	Rating life.....	92
2.	Calculation of service life under heaving operation condition.....	93
3.	Static safety factor.....	93
4.	Static equivalent load.....	94
5.	Dynamic radial load.....	94
6.	Load factor.....	95
6	Rated load	
1.	Basic static rated load.....	95
2.	Basic dynamic rated load.....	95
7	Permissible rpm	95
8	Lubrication	96
9	Cautions in designing compression plate and housing	
1.	Housing design for installation.....	96
2.	Tap for separation.....	96
3.	Installation & assembly.....	97
4.	Selection of compression flange and bolt ..	97
10	Fitting	99
11	Precision of crossed roller bearing	100
12	Precision of WUP series	
1.	Rotation accuracy of WUP series (example)	104
2.	Precision standard.....	104
13	Radial clearance	105
14	Dimension of crossed roller bearing	
1.	CB series.....	106
2.	CH series.....	108
15	Cautions when handling crossed roller bearing	110

Ball Spline

Contents

1	Ball Spline	
	1. Structures & Features.....	112
	2. Transmission of High Torque	112
	3. High load capacity and long life.....	112
	4. Zero Gap	112
2	Selection of Ball Spline	
	1. Overview.....	113
	2. Procedure	113
3	Life Calculation	
	1. Life	114
	2. Rating fatigue life L	114
	3. Static safety factor f_s	116
	4. Basic dynamic load rating C.....	117
	5. Basic static load rating C_0	117
	6. Basic dynamic rating torque T	117
	7. Basic static rating torque T_0 · Basic static rating moment T_M	117
4	Pre-load of Ball Spline	118
5	Accuracy	119
6	Lubrication and contamination prevention of Ball Spline	122
7	Assembly	123
8	Caution in Use	123
9	Compact Ball Spline	
	1. Structures and Features	124
	2. High torque transfer	124
	3. High load capacity and long life.....	124
10	Linear Ball Spline	
	1. Structures and Features	144
	2. High load capacity and long life	144
	3. Precise torque transfer	144
	4. High speed movement, High speed rotation.....	144
	5. Product classification.....	144
	6. Easy for further processing	144

Cross Roller Guide Way

Contents

1	Cross Roller Guide Way	
	1. Delicate slide, High rigidity & High accuracy	152
	2. Correspondence in load-direction & Zero-clearance	152
	3. Low noise	152
2	Anti-Creep Cross Roller Guide Way	
	1. Meet the application diversity	153
	2. Low Noise and working very smoothly	153
	3. Keep high load performance by the sound compatibility of assembly dimensions between old and new one	153
3	Types & Features	154
4	Accuracy	155
5	Safe working load & Service life	156
6	Pre-load	158
7	Accuracy of Mounting surface	159
8	Installation Method	159
9	Lubrication & Contamination Prevention	161
10	Caution in Use	162

Super Ball Bushing

Contents

1	Super Ball Bushing	
	1. 27 Times longer Travel life (3 Times Higher Load Capacity).....	186
	2. 0.5° Self-Aligning.....	186
	3. Ease of Replacement.....	186
	4. High speed and Fast acceleration.....	186
	5. Ease of Adjusting the radial clearance.....	187
	6. Installation cost reduction.....	187
	7. Smooth Running.....	187
	8. Environmental Temperature.....	187
2	Super Ball Bushing Type	
	1. Asian Standard.....	188
	2. European Standard.....	189
	2. Inch Standard.....	189
3	Life Span	
	1. Basic Dynamic Load Rating (C).....	190
	2. Hardness factor(f_H).....	190
	3. Temperature factor(f_T).....	191
	4. Load direction factor(f_D).....	191
	5. Basic Static Load Rating(C_0).....	191
	6. Housing and Shaft tolerance.....	192
4	Assembly	193

Linear Ball Bushing

Contents

1	Linear Ball Bushing	214
2	Types and Characteristics	215
3	Part Number	
	1. Standard Tolerance.....	217
	2. Load Rating & Travel Life.....	217
	3. Calculation Example	218
	4. Calculation of expected Travel Life ..	219
4	Equivalent factor	219
5	Lubrication & Friction	
	1. Grease Lubrication	221
	2. Oil Lubrication.....	221
	3. Coefficient of Friction.....	222
6	Assembly	
	1. Tolerance of Housing Bore	223
	2. Clearance of Outer Sleeve and Shaft	223
	3. Mounting.....	224
	4. Standard type	224
	5. Retaining ring for Mounting.....	224
	6. Setscrew Mounting Prohibited	224
	7. Flange type.....	225
	8. Mounting of Adjustable type.....	225
	9. Mounting of Open type.....	225
	10. Mounting of Shaft support.....	226
7	Mounting of LM case unit	
	1. Mounting of SH type.....	226
8	Cautions in use	
	1. Mounting of Linear Bushing	226
	2. Insertion of Shaft	227
	3. When Moment loads applied.....	227
	4. Avoid the Rotational Motion	227
	5. Mounting of open type Linear Bushing with three ball rows.....	227

Linear Motion Shaft

Contents

1	LM Shaft	
	1. Type of LM Shaft	240
	2. Materials	241
2	Heat Treatment	241
3	Precision Class	242
4	Equation of Deflection-Angle of LM Shaft	
	1. Case hardened & ground shaft	243
	2. Hollow shaft	243
5	Part Number of LM Shaft	
	1. Type number format I (Case hardened & ground shaft)	244
	2. Type number format II (Hollow shaft)	246
	3. Type number format III(tapped shaft)	247
6	LM Shaft End Support Block & Rail	
	1. Shaft End Support Block	248
	2. Shaft Support Rail	248

Track Roller Guide

Contents

1	T.R Guide	
	1. Structure & Features	256
	2. Speed and Noise	257
	3. Adjustable Clearance.....	257
	4. Load Capacity in any direction.....	257
	5. Perfect Sealing and Lubrication.....	257
	6. Available Temperature	257
	7. Easy Installation	257
2	Guide Rail Series	
	1. Outside Type	258
	2. Inside Type	259
3	Types of Block	
	1. Outside Type.....	260
	2. Inside Type.....	261
4	Assembly and Adjustment	
	1. Outside Type.....	262
	2. Inside Type.....	263
5	Track Roller	264
6	End Seal(T type).....	264
7	Cap Seal	264
8	Cap Seal Assembly	264
9	Accuracy.....	265
10	Service Life	
	1. Basic Dynamic Load Ratings C (Basic Dynamic Moment M)	266
	2. Basic Static Load Ratings Co (Basic Static Moment Mo)	266
	3. Maximum allowable load.....	266
	4. Service Life depending loads in any direction.....	266
	5. Service Life depending moment in any direction.....	266

Micro Stage

Contents

1	Linear Stage (Manual Stage)	288
2	Dovetail Stage (Manual Stage)	292
3	Dovetail Stage / Z Stage (Manual Stage)	293
4	Rotary Stage (Manual Stage)	294
5	Tilting Stage (Manual Stage)	296
6	Z Stage (Manual Stage)	297
7	Miniature Stage (Motorized Stage)	298
8	Miniature Stage / Z Stage (Motorized Stage)	299
9	Rotary Stage / Linear Stage (Motorized Stage)	300
10	Alignment Stage (Motorized Stage)	301

Appendix

Contents

1	Conversion Table from SI (Internation System of Units).....	304
2	N-kgf Conversion Table.....	306
3	kg-lb Conversion Table	307
4	Hardness Conversion Table.....	308
5	Dimensional Tolerance of Axis	310
6	Dimensional Tolerance of Housing Hole.....	312
7	Usage examples of Linear Motion Guide	314
8	Usage examples of Crossed Roller Bearing	322



WON
LINEAR MOTION SYSTEM

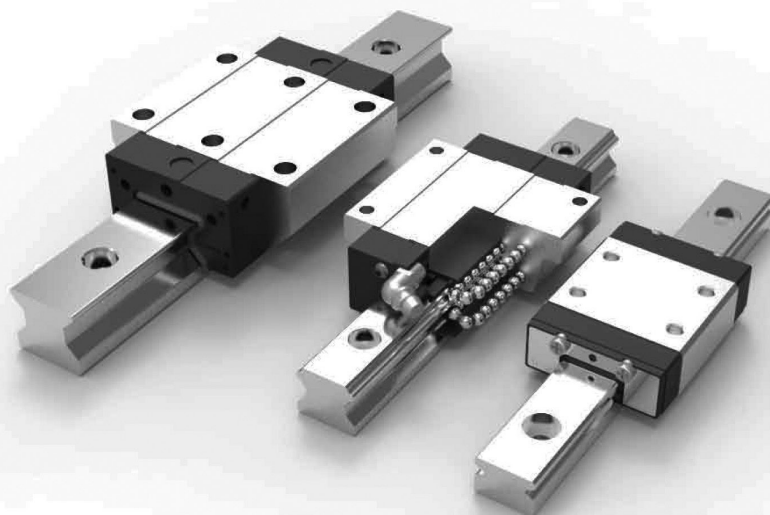

LINEAR MOTION GUIDE

1 WON Linear Motion Guide

1. Characteristics

WON Linear Motion Guide is a straight-line motion bearing with the structure in which rolling elements such as balls or rollers softly circulate the inner part of the block and the block can make an infinite straight-line motion along the raceway surface of a rail.

2. Strengths

1) Able to make a precise positioning

Since there is less difference between static friction and kinetic friction as well as in speed-induced friction fluctuation, it excellently responds even to micro-migration, allowing precise positioning.

2) Able to maintain accuracy stably for a long time

Less friction coefficient and wear due to ideal rolling motion allows the stable maintenance of accuracy for a long time.

3) Able to eliminate clearance or increase rigidity by preloading

It is possible to eliminate clearance by using rolling elements such as a ball or a roller or increase rigidity of Linear Motion Guide by preloading.

4) Lubrication is simple.

Lubrication is simple but it uses grease or oil which makes it convenient to maintain.

5) Able to compact equipment and save cost for operating electricity

It can be made into compact miniaturized equipment because friction is low despite highly-rigid high-loading, which saves manufacturing costs and energy.

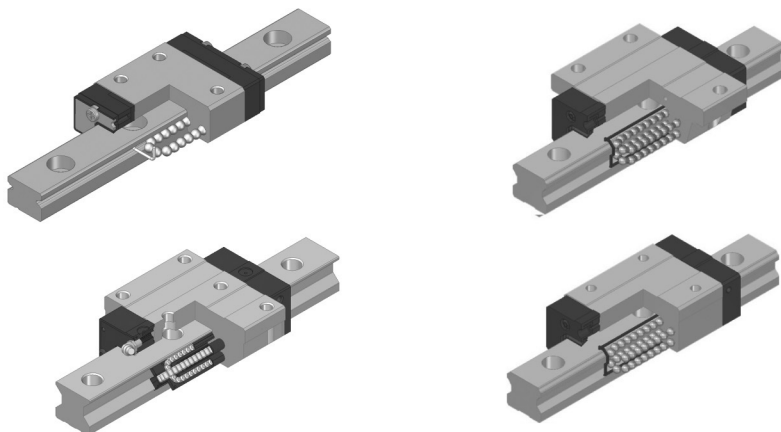

3. Types

WON ST offers various types of Linear Motion guide from miniature types to general ball Linear Motion guide to low-sound linear motion guide to ultra high-rigid roller linear motion guide. Since each supports different shapes and sizes according to service conditions, you can select the optimal linear motion guide to each usage.

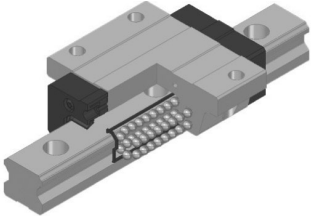
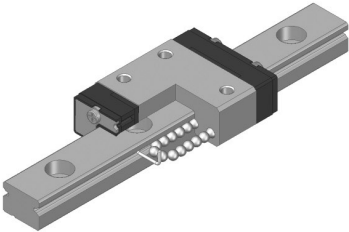
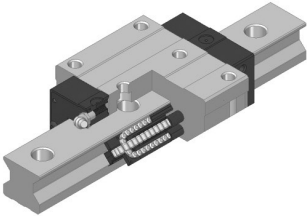











<p>Linear Motion Guide</p>		<ul style="list-style-type: none"> ·World standard ball Linear Motion guide ·4-direction equal load type with 40°contact angle ·Great error-absorbing ability with D/F combination ·High-rigid highly accurate straight-line motion through ideal rolling motion
<p>Miniature Linear Motion Guide</p>		<ul style="list-style-type: none"> ·Miniature high-rigidity ·Various shapes and sizes ·Highly-durable and reliable compact straight-line motion device
<p>Roller Linear Motion Guide</p>		<ul style="list-style-type: none"> ·Roller-enabled ultra-rigid linear motion guide ·4-direction equal load type with 40°contact angle ·Able to run reliably for a long time through rolling motion having wide contact surface ·High-load, high-rigid, highly accurate straight-line motion

2 Selection of Linear Motion Guide

1. Overview

To select Linear Motion guide, most of all identify detailed requirements and prioritize the requirements to select the Linear Motion Guide suitable for the service conditions.

2. Procedure

- 1 Identify service conditions  equipment, maintenance structure, installation space, assembly status, functional requirements, service conditions
- 2 Select the type of Linear Motion guide  Select the appropriate type by considering motion condition, load level, rigidity, friction, and assembly
- 3 Select the model number of Linear Motion guide  Determine the model number and the quantity of blocks by considering the space and load
- 4 Calculate load  Calculate the load in vertical and horizontal directions and moment
- 5 Calculate equivalent load  Calculate each load applied to the block by converting it into equivalent load
- 6 Calculate mean load  Calculate each load applied to the block and variable load during deceleration by converting them into mean load
- 7 Calculate static safety factor  Calculate the static safety factor identified by basic load rating and max. equivalent load and check if it fits for service conditions
- 8 Calculate life  Check if it fits for service conditions by calculating load rating and life
- 9 Review preload & clearance  Select the preload and clearance suitable for service conditions
- 10 Determine the class of precision  Determine the class of precision required by Linear Motion guide while driving
- 11 Lubrication, dust proof, surface handling  Select lubricant suitable for the environment using grease, oil, and special grease lubrication and select seal for dust proof / determine the method of surface handling for rust prevention and low dust raise
- 12 Complete selection  Complete the decision of final specifications of Linear Motion guide

3 Life Calculation

1. Load rating and life

(1) Life

If external load is applied to Linear Motion guide while driving, fatigue fracture occurs by stress created as load is repeatedly applied to the raceway surface and rolling elements, and flaking -peeling off in scale-like flakes arises. A total driving distance until flaking occurs due to initial fatigue fracture is the life of a linear motion guide.

- Defects may occur in Linear Motion guide earlier than when flaking normally occurs due to wear or fatigue in the following cases:
 - a. Excess load by the imprecise assembly following a difference in temperature or tolerance
 - b. If Linear Motion guide is contaminated with foreign substance
 - c. Driving with insufficient lubrication
 - d. Reciprocating motion in a very short distance in the form of vibration or wave during the halt or drive
 - e. Excessive load to Linear Motion guide
 - f. Deformation of plastic end-plate

2) Rating fatigue life L

Generally Linear Motion guide does not always have same life even though the products are manufactured in the same way because of the difference in scattering of raw material's original fatigue. For this reason, the reference value of life is defined as the rating fatigue life which is a total driving distance that flaking does not occur in 90% of Linear Motion guides in a group when having them run under the same conditions by grouping multiple Linear Motion guides with same specifications into a group.

When using a ball

$$L = \left(\frac{f_H \cdot f_T \cdot f_C}{f_w} \cdot \frac{C}{P_c} \right)^3 \times 50$$

When using a roller

$$L = \left(\frac{f_H \cdot f_T \cdot f_C}{f_w} \cdot \frac{C}{P_c} \right)^3 \times 100$$

(3) Basic dynamic load rating C

Basic dynamic load rating is Linear Motion guide's bearing of load which represents an applicable constant load in direction and magnitude when the rated life is 50KM. The reference value of WON Linear Motion Guide's basic dynamic load rating is 50KM (ball type) and 100KM (roller type). It is used for calculating Linear Motion guide's life while driving under constant load in magnitude from the center of a block to bottom.

Each value of basic dynamic load rating (C) is stated in the catalogue.

(4) Basic static load rating C₀

If Linear Motion guide is applied by excessive load or attached instantly by big impact load, a partially permanent deformation occurs between a rolling element and the raceway surface. If deformation reaches to a certain extent, it hinders a smooth driving. Basic static load rating is defined as the constant static load in direction and magnitude with the permanent deformation that occurs between a rolling element like a ball or a roller and the raceway surface of block and rail 0.0001 times bigger than the diameter of the rolling element. In Linear Motion guide, it is the load applied from top to bottom based on the center of the block. Each value of basic static load rating (C₀) is stated in the specification table.

(5) Static allowable moment M_o

Moment load can be applied to Linear Motion guide. Here, a ball or a roller both at the ends is most stressed due to the stress distribution of a ball or a roller which is the rolling element inside Linear Motion guide. Static allowable moment refers to the constant moment load in direction and magnitude when the permanent deformation between a ball or a roller applied with the biggest stress and the raceway surface of a block or a rail is less than 0.0001 of the diameter of the rolling element. Moment values of three directions (M_p , M_y , M_r) are stated in the specification sheet. Static allowable moment (M_o) and static moment load rating (M_p) can be reviewed by applying safety factor (f_s).

Directions of load and moment

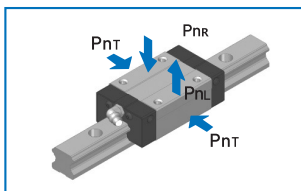
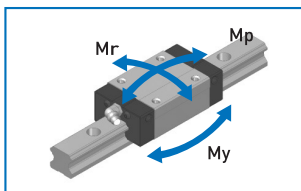

$$f_s = \frac{M_p}{M_o}$$

2. Load Calculation

Linear Motion guide bears basic dynamic load rating (C) and basic static load rating (C_o). But compression load applied from top to down due to inertia force created by the center of gravity, positioning thrust, acceleration, cutting force, and deceleration as well as various loads including tensile load, horizontal load, and moment load can be applied to Linear Motion guide depending on the service conditions. In this case, load of Linear Motion guide changes. When selecting Linear Motion guide, it is required to review these conditions and calculate proper load.

3. Service Condition Setting

Service conditions necessary for calculating the load and life of Linear Motion guide :

- | | | | | |
|---|----------------------|--|-----------------|----------------------------|
| ① Mass : | m (kg) | ⑥ Velocity diagram | Velocity : | V (mm/s) |
| ② Applicable load direction | | | Time constant : | t_n (s) |
| ③ Point of application :
(center of gravity) | l_2, l_3, h_1 (mm) | | Acceleration : | a_n (mm/s ²) |
| ④ Point of thrust : | l_4, h_2 (mm) | ⑦ No. of reciprocating motion/second : | | N_1 (min ⁻¹) |
| ⑤ Composition of Linear Motion guide :
(No. of block & rail) | l_0, l_1 (mm) | ⑧ Stroke : | | L_s (mm) |
| | | ⑨ Avg. velocity : | | V_m (m/s) |
| | | ⑩ Required life : | | L_h (h) |

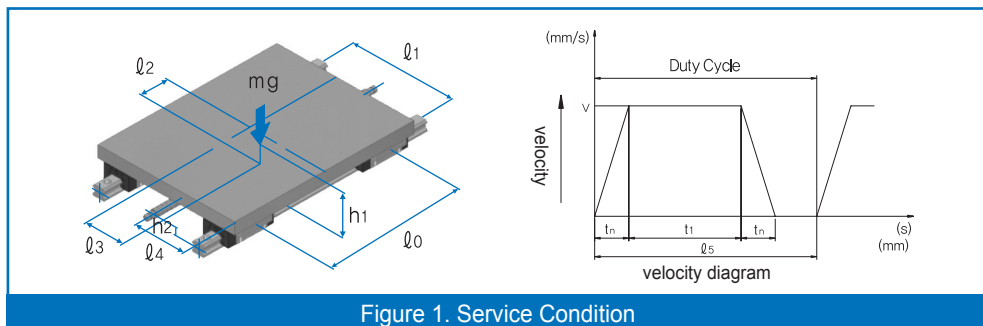
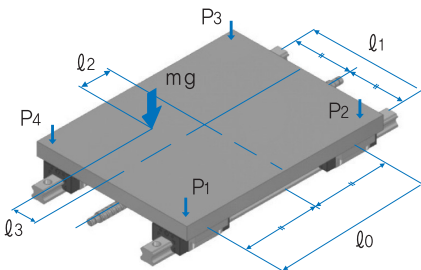
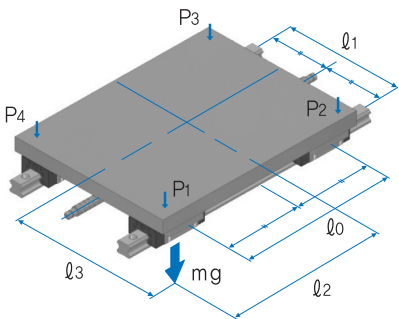

Figure 1. Service Condition

4. Load Calculation Formula

Load applied to Linear Motion guide changes due to external forces such as the center of gravity, position of thrust, acceleration, and cutting resistance. To select Linear Motion guide, you should calculate load applied to the block by fully considering the conditions below.

m : Mass	(kg)	g : Acceleration of gravity(g : 9.8m/s ²)	(m/s ²)
ℓ _n : Distance	(mm)	V : Velocity	(m/s)
F _n : Thrust	(N)	tn : Time constant	(s)
P _n : Load (vertical, reverse-vertical)	(N)	an : Acceleration	(m/s ²)
P _{nr} : Load (horizontal)	(N)		

Case	Service Conditions	Load Calculation Formula
1	Block move Horizontal / uniform motion / halt 	$P_1 = \frac{mg}{4} + \frac{mg \cdot l_2}{2 \cdot l_0} - \frac{mg \cdot l_3}{2 \cdot l_1}$ $P_2 = \frac{mg}{4} - \frac{mg \cdot l_2}{2 \cdot l_0} - \frac{mg \cdot l_3}{2 \cdot l_1}$ $P_3 = \frac{mg}{4} - \frac{mg \cdot l_2}{2 \cdot l_0} + \frac{mg \cdot l_3}{2 \cdot l_1}$ $P_4 = \frac{mg}{4} + \frac{mg \cdot l_2}{2 \cdot l_0} + \frac{mg \cdot l_3}{2 \cdot l_1}$
2	Block move Overhang-horizontal / uniform motion / halt 	$P_1 = \frac{mg}{4} + \frac{mg \cdot l_2}{2 \cdot l_0} + \frac{mg \cdot l_3}{2 \cdot l_1}$ $P_2 = \frac{mg}{4} - \frac{mg \cdot l_2}{2 \cdot l_0} + \frac{mg \cdot l_3}{2 \cdot l_1}$ $P_3 = \frac{mg}{4} - \frac{mg \cdot l_2}{2 \cdot l_0} - \frac{mg \cdot l_3}{2 \cdot l_1}$ $P_4 = \frac{mg}{4} + \frac{mg \cdot l_2}{2 \cdot l_0} - \frac{mg \cdot l_3}{2 \cdot l_1}$

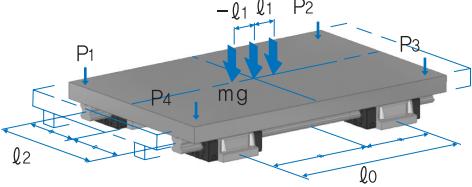
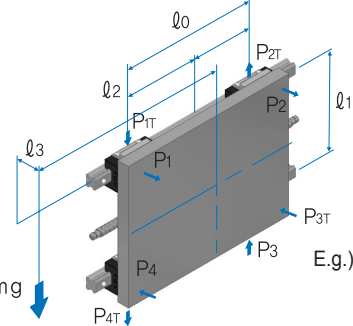
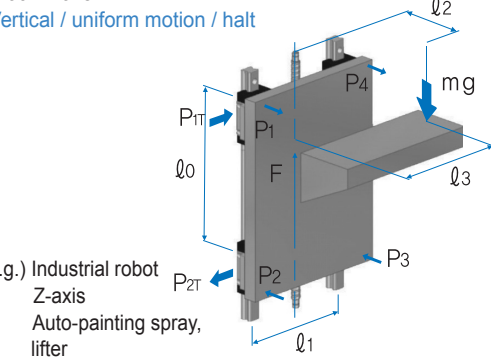
Case	Service Conditions	Load Calculation Formula
3	<p>Rail move Horizontal / uniform motion / halt</p>  <p>E.g.) X or Z axis Loader/unLoader</p>	$P_1 = \frac{mg \cdot \cos\theta}{4} + \frac{mg \cdot \cos\theta \cdot l_2}{2 \cdot l_0}$ $- \frac{mg \cdot \cos\theta \cdot l_3}{2 \cdot l_1} + \frac{mg \cdot \sin\theta \cdot h_1}{2 \cdot l_1}$ $P_{1T} = \frac{mg \cdot \sin\theta}{4} + \frac{mg \cdot \sin\theta \cdot l_2}{2 \cdot l_0}$ $P_2 = \frac{mg \cdot \cos\theta}{4} - \frac{mg \cdot \cos\theta \cdot l_2}{2 \cdot l_0}$ $- \frac{mg \cdot \cos\theta \cdot l_3}{2 \cdot l_1} + \frac{mg \cdot \sin\theta \cdot h_1}{2 \cdot l_1}$ $P_{2T} = \frac{mg \cdot \sin\theta}{4} - \frac{mg \cdot \sin\theta \cdot l_2}{2 \cdot l_0}$
4	<p>Block move Wall installation / uniform motion / halt</p>  <p>E.g.) Gantry-type device Y-axis drive</p>	$P_1 \sim P_4 = \frac{mg \cdot l_3}{2 \cdot l_1}$ $P_{1T} = P_{4T} = \frac{mg}{4} + \frac{mg \cdot l_2}{2 \cdot l_0}$ $P_{2T} = P_{3T} = \frac{mg}{4} - \frac{mg \cdot l_2}{2 \cdot l_0}$
5	<p>Block move Vertical / uniform motion / halt</p>  <p>E.g.) Industrial robot Z-axis Auto-painting spray, lifter</p>	$P_1 \sim P_4 = \frac{mg \cdot l_2}{2 \cdot l_0}$ $P_{1T} \sim P_{4T} = \frac{mg \cdot l_3}{2 \cdot l_0}$

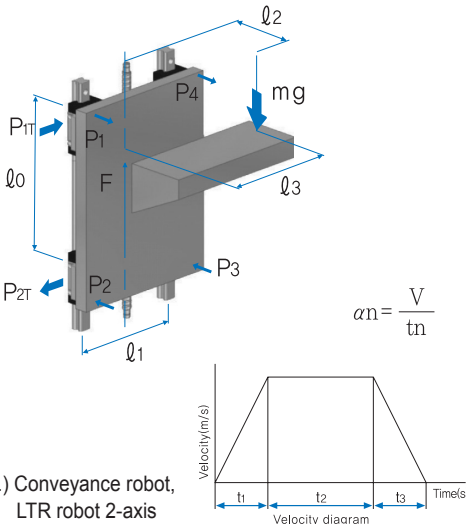
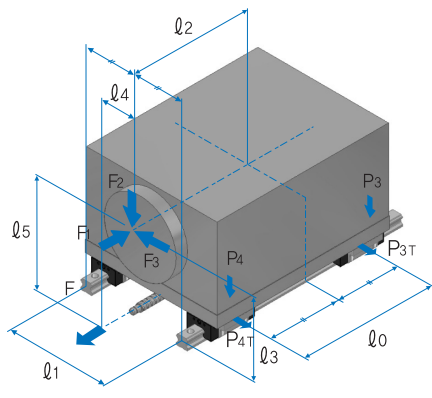
Case	Service Conditions	Load Calculation Formula
6	<p>Block move Vertical/moment of inertia</p>  <p>E.g.) Conveyance robot, LTR robot 2-axis</p>	<p>Acceleration</p> $P_1=P_4 = -\frac{m(g-\alpha)l_2}{2 \cdot l_0}$ $P_2=P_3 = \frac{m(g-\alpha)l_2}{2 \cdot l_0}$ $P_{1T}=P_{4T} = \frac{m(g-\alpha)l_3}{2 \cdot l_0}$ $P_{2T}=P_{3T} = -\frac{m(g-\alpha)l_3}{2 \cdot l_0}$ <p>Uniform motion</p> $P_1=P_4 = -\frac{mg \cdot l_2}{2 \cdot l_0}$ $P_2=P_3 = \frac{mg \cdot l_2}{2 \cdot l_0}$ $P_{1T}=P_{4T} = \frac{mg \cdot l_3}{2 \cdot l_0}$ $P_{2T}=P_{3T} = -\frac{mg \cdot l_3}{2 \cdot l_0}$ <p>Deceleration</p> $P_1=P_4 = -\frac{m(g-\alpha_3)l_2}{2 \cdot l_0}$ $P_2=P_3 = \frac{m(g-\alpha_3)l_2}{2 \cdot l_0}$ $P_{1T}=P_{4T} = \frac{m(g-\alpha_3)l_3}{2 \cdot l_0}$ $P_{2T}=P_{3T} = -\frac{m(g-\alpha_3)l_3}{2 \cdot l_0}$
7	<p>Block move Cutting load / complex external load</p>  <p>E.g.) Machine tool, CNC shelf, maching center, NC milling machine</p>	<p>F1 application</p> $P_1=P_4 = -\frac{F_1 \cdot l_5}{2 \cdot l_0}$ $P_2=P_3 = \frac{F_1 \cdot l_5}{2 \cdot l_0}$ $P_{1T}=P_{4T} = \frac{F_1 \cdot l_4}{2 \cdot l_0}$ $P_{2T}=P_{3T} = -\frac{F_1 \cdot l_4}{2 \cdot l_0}$ <p>F2 application</p> $P_1=P_4 = \frac{F_2}{4^+} \cdot \frac{F_2 \cdot l_2}{2 \cdot l_0}$ $P_2=P_3 = \frac{F_2}{4^-} \cdot \frac{F_2 \cdot l_2}{2 \cdot l_0}$ <p>F3 application</p> $P_1=P_4 = -\frac{F_3 \cdot l_3}{2 \cdot l_1}$ $P_2=P_3 = \frac{F_3 \cdot l_3}{2 \cdot l_1}$ $P_{1T}=P_{4T} = \frac{F_3}{4^-} \cdot \frac{F_3 \cdot l_2}{2 \cdot l_0}$ $P_{2T}=P_{3T} = \frac{F_2}{4^-} \cdot \frac{F_3 \cdot l_2}{2 \cdot l_0}$

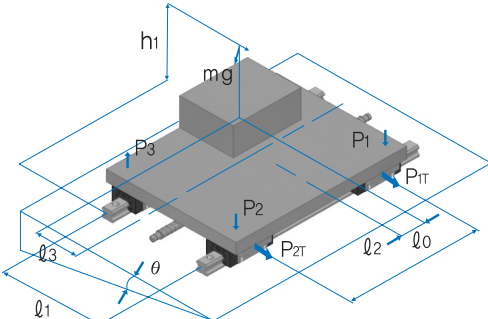
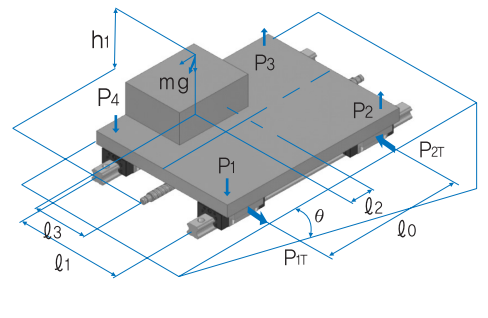
Case	Service Conditions	Load Calculation Formula
8	<p>Block move Moment load in case of application to side slope / cutting load</p>  <p>E.g.) CNC shelf, reciprocating carriage</p>	$P_1 = \frac{mg \cdot \cos \theta}{4} + \frac{mg \cdot \cos \theta \cdot l_2}{2 \cdot l_0}$ $- \frac{mg \cdot \cos \theta \cdot l_3}{2 \cdot l_1} + \frac{mg \cdot \sin \theta \cdot h_1}{2 \cdot l_1}$ $P_{1T} = \frac{mg \cdot \sin \theta}{4} + \frac{mg \cdot \sin \theta \cdot l_2}{2 \cdot l_0}$ $P_2 = \frac{mg \cdot \cos \theta}{4} - \frac{mg \cdot \cos \theta \cdot l_2}{2 \cdot l_0}$ $- \frac{mg \cdot \cos \theta \cdot l_3}{2 \cdot l_1} + \frac{mg \cdot \sin \theta \cdot h_1}{2 \cdot l_1}$ $P_{2T} = \frac{mg \cdot \sin \theta}{4} - \frac{mg \cdot \sin \theta \cdot l_2}{2 \cdot l_0}$ $P_3 = \frac{mg \cdot \cos \theta}{4} - \frac{mg \cdot \cos \theta \cdot l_2}{2 \cdot l_0}$ $+ \frac{mg \cdot \cos \theta \cdot l_3}{2 \cdot l_1} - \frac{mg \cdot \sin \theta \cdot h_1}{2 \cdot l_1}$ $P_{3T} = \frac{mg \cdot \sin \theta}{4} + \frac{mg \cdot \sin \theta \cdot l_2}{2 \cdot l_0}$ $P_4 = \frac{mg \cdot \cos \theta}{4} + \frac{mg \cdot \cos \theta \cdot l_2}{2 \cdot l_0}$ $+ \frac{mg \cdot \cos \theta \cdot l_3}{2 \cdot l_1} - \frac{mg \cdot \sin \theta \cdot h_1}{2 \cdot l_1}$ $P_{4T} = \frac{mg \cdot \sin \theta}{4} + \frac{mg \cdot \sin \theta \cdot l_2}{2 \cdot l_0}$
9	<p>Block move Moment load in case of application to front slope / cutting load</p>  <p>E.g.) CNC shelf, tool rest</p>	$P_1 = \frac{mg \cdot \cos \theta}{4} + \frac{mg \cdot \cos \theta \cdot l_2}{2 \cdot l_0}$ $- \frac{mg \cdot \cos \theta \cdot l_3}{2 \cdot l_1} + \frac{mg \cdot \sin \theta \cdot h_1}{2 \cdot l_0}$ $P_{1T} = \frac{mg \cdot \sin \theta \cdot l_3}{2 \cdot l_0}$ $P_2 = \frac{mg \cdot \cos \theta}{4} - \frac{mg \cdot \cos \theta \cdot l_2}{2 \cdot l_0}$ $- \frac{mg \cdot \cos \theta \cdot l_3}{2 \cdot l_1} - \frac{mg \cdot \sin \theta \cdot h_1}{2 \cdot l_0}$ $P_{2T} = - \frac{mg \cdot \sin \theta \cdot l_3}{2 \cdot l_0}$ $P_3 = \frac{mg \cdot \cos \theta}{4} - \frac{mg \cdot \cos \theta \cdot l_2}{2 \cdot l_0}$ $+ \frac{mg \cdot \cos \theta \cdot l_3}{2 \cdot l_1} - \frac{mg \cdot \sin \theta \cdot h_1}{2 \cdot l_0}$ $P_{3T} = - \frac{mg \cdot \sin \theta \cdot l_3}{2 \cdot l_0}$ $P_4 = \frac{mg \cdot \cos \theta}{4} + \frac{mg \cdot \cos \theta \cdot l_2}{2 \cdot l_0}$ $+ \frac{mg \cdot \cos \theta \cdot l_3}{2 \cdot l_1} + \frac{mg \cdot \sin \theta \cdot h_1}{2 \cdot l_0}$ $P_{4T} = \frac{mg \cdot \sin \theta \cdot l_3}{2 \cdot l_0}$

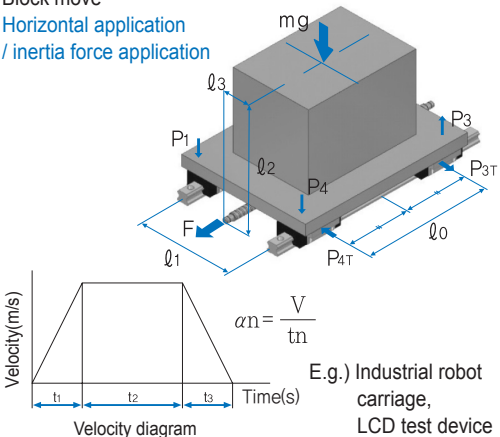
Case	Service Conditions	Load Calculation Formula
10	<p>Block move Horizontal application / inertia force application</p>  <p>E.g.) Industrial robot carriage, LCD test device</p>	<p>Acceleration</p> $P_{1}=P_{4}=\frac{mg}{4}-\frac{m \cdot \alpha \cdot l_{2}}{2 \cdot l_{0}}$ $P_{2}=P_{3}=\frac{mg}{4}+\frac{m \cdot \alpha \cdot l_{2}}{2 \cdot l_{0}}$ $P_{1T} \sim P_{4T}=\frac{m \cdot \alpha \cdot l_{3}}{2 \cdot l_{0}}$ <p>Constant velocity</p> $P_{1} \sim P_{4}=\frac{mg}{4}$ <p>Deceleration</p> $P_{1}=P_{4}=\frac{mg}{4}+\frac{m \cdot \alpha \cdot l_{2}}{2 \cdot l_{0}}$ $P_{2}=P_{3}=\frac{mg}{4}-\frac{m \cdot \alpha \cdot l_{2}}{2 \cdot l_{0}}$ $P_{1T} \sim P_{4T}=\frac{m \cdot \alpha \cdot l_{3}}{2 \cdot l_{0}}$

5. Equivalent Load Calculation

There are diverse kinds of load applied to Linear Motion guide, such as compression load in vertical direction, tensile load, horizontal load, moment load, etc. There is also combined load of them and sometimes the magnitude and direction of load change. Since it is hard to calculate the variable load when calculating the life of Linear Motion guide, it is required to use equivalent load which is converted to compression load or tensile load in vertical direction in order to produce life or static safety factor.

6. Equivalent Load Calculation Formula

If Linear Motion guide bears vertical compression load or tensile load or horizontal load simultaneously, or the magnitude or direction of load changes, equivalent load is calculated using the following formula.

$$P_E(\text{equivalent load}) = P_n + P_{nT}$$

P_n : Compression load
 P_{nT} : Horizontal load

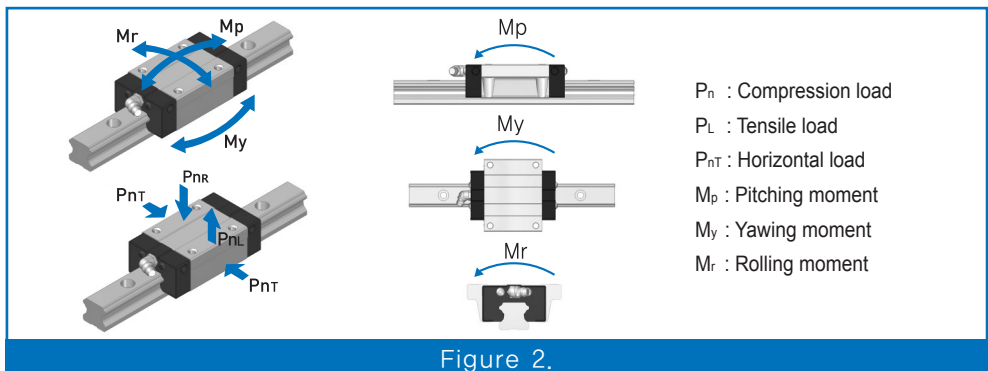

Figure 2.

7. Static Safety Factor Calculation

Unexpected big load may be applied to Linear Motion guide due to inertia force caused by vibration impact or quick braking and moment load of mechanical structure. When selecting Linear Motion guide, static safety factor must be taken into account to be ready for such load. Static safety factor (f_s) is shown in value obtained by dividing basic static load rating by the calculated load. To see the baseline of static safety factor by service condition, please refer to Table 1-1 and Table 1-2.

Table 1-1 Baseline of static safety factor(s)

Type of rolling element	Service condition	Static safety factor (f_s)
Ball	There is no vibration and impact.	1.0 ~ 1.5
	Great travel performance is needed.	1.5 ~ 2.0
	There are moment load, vibration, and impact.	2.5 ~ 7.0
Roller	There is no vibration and impact.	2.0 ~ 3.0
	Great travel performance is needed.	3.0 ~ 5.0
	There are moment load, vibration, and impact.	4.0 ~ 7.0

Table 1-2

If compression load is big	$\frac{f_H \cdot f_T \cdot f_C \cdot C_0}{P_n} \geq f_s$
If tensile load is big	$\frac{f_H \cdot f_T \cdot f_C \cdot C_{OL}}{P_L} \geq f_s$
If horizontal load is big	$\frac{f_H \cdot f_T \cdot f_C \cdot C_{OT}}{P_{nT}} \geq f_s$

f_s : Static safety factor

C_0 : Basic static load rating(vertical)

C_{OL} : Basic static load rating(reverse-vertical)

C_{OT} : Basic static load rating(horizontal)

P_n : Calculated load(vertical)

P_L : Calculated load (reverse-vertical) (N)

P_{nT} : Calculated load (horizontal) (N)

f_H : Hardness factor

f_T : Temperature factor

f_C : Contact factor

8. Mean Load Calculation

Load applied to the block of Linear Motion guide is not constant, but differs according to service conditions. Here the load that becomes equal to life under variable load is used. This is called mean load. If the load applied to block is changed due to external condition, it is required to calculate life as mean load that includes various conditions as below. If load applied to block varies with different conditions, life should be calculated by including this variable load condition. Mean load (Pm) refers to constant load that becomes equal to life under this variable load when the load applied to block changes with various conditions while traveling.

$$P_m = \sqrt[\dot{i}]{\frac{1}{L} \cdot \sum_{n=1}^n (P_n^i \cdot L_n)}$$

- P_m : Mean load (N)
- P_n : Variable load (N)
- L : Total travel distance (mm)
- L_n : Travel distance by loading P_n (mm)
- i* : Ball - 3, Roller - 10/3

Note) the formula above or formula (1) below is applied to a ball.

1) Change in phase

$$P_m = \sqrt[\dot{i}]{\frac{1}{L}(P_1^i \cdot L_1 + P_2^i \cdot L_2 + \dots + P_n^i \cdot L_n)} \dots (1)$$

- P_m : Mean load (N)
- P_n : Variable load (N)
- L : Total travel distance (mm)
- L_n : Travel distance by loading P_n (mm)

2) Change monotonously

$$P_m \approx \frac{1}{3}(P_{min} + 2 \cdot P_{max}) \dots (2)$$

- P_{min} : Minimum load (N)
- P_{max} : Maximum load (N)

3) Change in a sine curve

a) $P_m \approx 0.65 \max \dots (3)$

b) $P_m \approx 0.75 \max \dots (4)$

9. Rating Life Calculation

Rating life needs to be calculated because Linear Motion guide's life differs even under same working conditions. Rating life of Linear Motion guide is the total travel distance that a Linear Motion guide system composed of a certain number of units can drive until flaking does not occur in 90% of the raceway surface or rolling elements after being run under same working conditions. If a ball or a roller is used as a rolling element, rating life can be calculated using the following formula.

▶ Calculation formula of the rating life of ball-enabled Linear Motion guide

$$L = \left(\frac{f_H \cdot f_T \cdot f_C}{f_w} \cdot \frac{C}{P_C} \right)^3 \times 50$$

L	: Rating life	(km)
C	: Basic dynamic load rating	(N)
P _C	: Calculated load	(N)
f _H	: Hardness factor	See Fig. 3
f _T	: Temperature factor	See Fig. 4
f _C	: Contact factor	See Table 2
f _w	: Load factor	See Table 3

▶ Calculation formula of the rating life of roller-enabled Linear Motion guide

$$L = \left(\frac{f_H \cdot f_T \cdot f_C}{f_w} \cdot \frac{C}{P_C} \right)^{\frac{10}{3}} \times 100$$

L	: Rating life	(km)
C	: Basic dynamic load rating	(N)
P _C	: Calculated load	(N)
f _H	: Hardness factor	See Fig. 3
f _T	: Temperature factor	See Fig. 4
f _C	: Contact factor	See Table 2
f _w	: Load factor	See Table 3

▶ If the length of stroke and the number of reciprocating motion are constant, life time can be calculated using rating life (L) by the formula below.

$$L_h = \frac{L \times 10^6}{2 \times l_s \times n_1 \times 60}$$

L _h	: Life time	(N)
l _s	: Length of stroke	(mm)
n ₁	: No. of reciprocating motion per minute	(mm ⁻¹)

1) Hardness factor (f_H)

To realize the best performance of Linear Motion guide, the proper hardness and depth should be maintained between the block contacting a rolling element (ball or roller) and the raceway surface of rail.

WON Linear Motion guide has HRC58-64 surface hardness, so there is no need to consider hardness factor. But if the hardness is lowered than baseline, Linear Motion guide's load capacity decreases; so hardness factor needs to be reflected in calculating life.

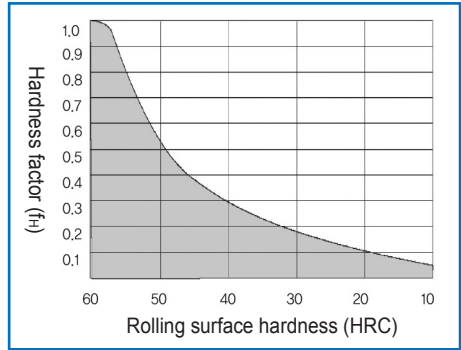

Figure 3. Hardness factor (f_H)

2) Temperature factor (f_T)

If high temperature over 100°C is applied to Linear Motion guide, temperature factor (f_T) needs to be taken into account when selecting Linear Motion guide. WON Linear Motion guide must be used at less than 80°C. But you have to use it at over 80°C, please use a high-temp Linear Motion guide - WON ST's specially customized product.

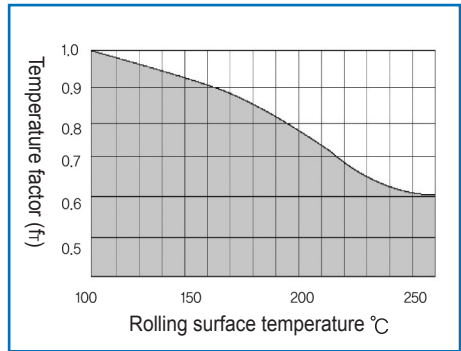

Figure 4. Temperature factor (f_T)

Note) In ambient temperature of over 80°C, materials for seal, end plate, and support plate should be changed to the specifications for high temperature.

3) Contact factor (f_c)

If over two blocks of Linear Motion guide are closely assembled, since uniform load may not be applied to blocks due to difference among mounting surfaces, you have to multiply basic static load rating (C) and basic dynamic load rating (C_0) by contact factor shown in Table 2.

No. of blocks contacted	Contact factor (f_c)
2	0.81
3	0.72
4	0.66
5	0.61
Over 6	0.6
Common use	1.0

4) Load factor (f_w)

Generally the static load applied to the block of Linear Motion guide can be calculated by formula. But the load applied to the block while running the machine tends to come from vibration or impact. Therefore, you have to consider load factor (f_w) shown in Table 3 for the vibration or impact load during the speedy running of the machine. It can be calculated by dividing the basic dynamic load rating of Linear Motion guide by load factor (f_w).

Table 3.

External condition	Service conditions	Load factor (f_w)
Low	There is no external vibration or impact due to the smooth running of machine at mild speed.	1.0 ~ 1.3
Moderate	There is moderate external vibration or impact due to the running of machine at low speed.	1.2 ~ 1.5
Big	There is strong vibration or impact due to the running of machine at fast speed.	1.5 ~ 2.0
Very big	There is strong vibration or impact due to the running of machine at very fast speed.	2.0 ~ 4.0

4 Rigidity & Preload

1. Preload

Linear Motion guide is preloaded in a way that improves mechanical precision by eliminating clearance using the rolling element (ball or roller) inserted into the space between rail and the block or in a way that applies load to the rolling element in advance by inserting the rolling element larger in size than the clearance of raceway between rail and the block. This process will enhance the rigidity of Linear Motion guide and lessen the displacement level caused by external load.

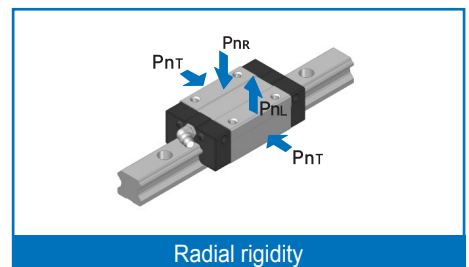
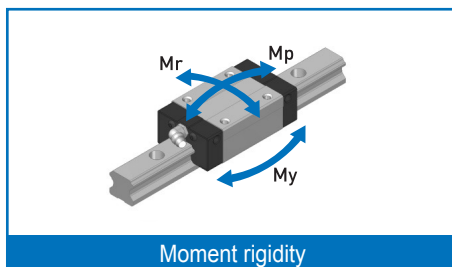
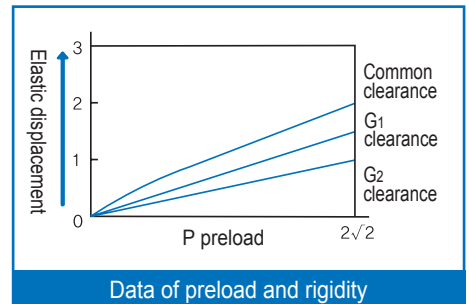
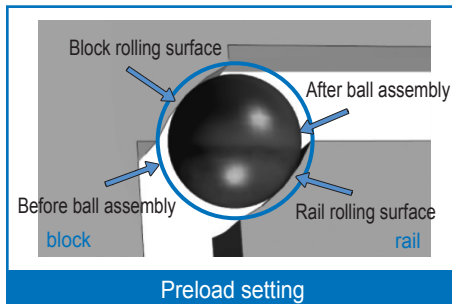

2. Radial Clearance

Radial clearance refers to the total travel distance in a radial direction from the center of the block of Linear Motion guide when mild load is applied to the block up and down from the center part of the rail length after the block is assembled in the rail which is then fixed to base.

Radial clearance is usually classified into common clearance (no symbol), G₁ clearance (light preload), G₂ clearance (heavy load), and G_s clearance (special preload), and are optional depending on usage. The values are standardized by form.

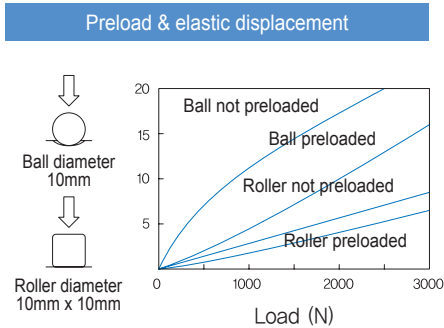

	Preload type	Preload symbol	Preload symbol
H	Moderate	No symbol	0 ~ 0.03 x C
	Light	G ₁	0.04 ~ 0.08 x C
	Heavy	G ₂	0.09 ~ 0.13 x C
S	Moderate	No symbol	0 ~ 0.03 x C
	Light	G ₁	0.03 ~ 0.05 x C
	Heavy	G ₂	0.06 ~ 0.08 x C

Table 4. Service condition for radial clearance (preload)

Type	Preload status	Symbol	Service Conditions	Use
1. Moderate	Plus-minus clearance	No (1)	<ul style="list-style-type: none"> Load is applied in uniform direction and smooth running is needed. There is almost no vibration or impact and precise running is required. 	Welding machine, textile machinery, packaging machinery, various conveyors, medical equipment, woodworking machine, glass cutting machine, take-out robots, ATC, winding machine
2. Light	Minus clearance in small amount	G ₁ (2)	<ul style="list-style-type: none"> There is a little vibration or impact and moment load. Light load is applied, yet high precision is required. 	Various industrial robots, measuring equipment, inspection equipment, 3D processor, laser processor, PCB drilling machine, various assembling machine, electric spark machine, punching press
3. Heavy	Minus clearance in large amount	G ₂ (3)	<ul style="list-style-type: none"> There is mild impact load or overhang load and moment load. Rigidity and high precision are required. 	CNC shelf, machining center, milling machine, grinding machine, tapping center, drilling machine, hobbing machine, various special equipment
4. Special	Minus clearance in small or large amount	G _s (4)	<ul style="list-style-type: none"> With smaller clearance than that of G₁ preload, light and precise operation is required. 	No preload, ultra-light preload, larger-than-moderate preload, special preload customized to user's conditions, special processing machine for heavy-duty cutting

Note (1) No clearance or very small clearance.

(2) Very small minus clearance.

(3) Quiet large minus clearance to enhance rigidity

(4) Preload below G₁ or over G₂ to meet service conditions

Table 5. Radial clearance of H & S Series

Unit : μm

Model No.		Symbol		
		Moderate	Light preload	Heavy preload
		No symbol	G ₁	G ₂
H15	S15	-4 ~ +2	-12 ~ -4	-
H20	S20	-5 ~ +2	-14 ~ -5	-23 ~ -14
H25	S25	-6 ~ +3	-16 ~ -6	-26 ~ -16
H30	-	-7 ~ +4	-19 ~ -7	-31 ~ -19
H35	-	-8 ~ +4	-22 ~ -8	-35 ~ -22
H45	-	-10 ~ +5	-25 ~ -10	-40 ~ -25
H55	-	-12 ~ +5	-29 ~ 12	-46 ~ -29

Table 6. Radial clearance of M & MB Series

Unit : μm

Model No.		Symbol	
		Moderate	Light preload
		No symbol	G ₁
M5	MB5	0 ~ +1.5	-1 ~ 0
M7	MB7	-2 ~ +2	-3 ~ 0
M9	MB9	-2 ~ +2	-4 ~ 0
M12	MB12	-3 ~ +3	-6 ~ 0
M15	MB15	-5 ~ +5	-10 ~ 0
M20	-	-7 ~ +7	-14 ~ 0

Table 7. Radial clearance of R Series

Unit : μm

Model No.		Symbol		
		Moderate	Light preload	Heavy preload
		No symbol	G ₁	G ₂
R35		-2 ~ -1	-3 ~ -2	-5 ~ -3
R45		-2 ~ -1	-3 ~ -2	-5 ~ -3
R55		-2 ~ -1	-4 ~ -2	-6 ~ -4

5 Friction

1. Friction

Linear Motion guide's friction resistance occurs to the level of 1/20~1/40 compared to existing sliding guide since the rolling element (ball or roller) is assembled between the rail and the block which is the raceway surface. Also starting torque is low because the difference between static friction and kinetic friction is very small. Its low power loss and temperature rise in the part of linear motion are of advantage to speedy operation. Its high conformability and response realize the highly precise positioning.

2. Friction Coefficient

Friction resistance of Linear Motion guide relies on the load applied to Linear Motion guide, speed, lubrication or form. In case of light load or high-speedy motion, lubrication or seal is the main cause of friction resistance. In case of heavy load or slow motion, the magnitude of load affects friction resistance.

$$F = \mu P$$

F : Friction resistance (N)
 μ : Kinetic friction factor
 P : Load (N)

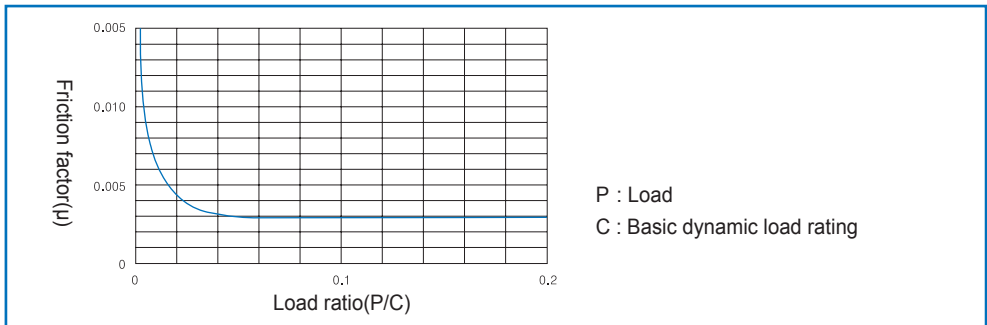

Figure 5. Relation between load ratio and friction factor

Common friction factors of various operating systems are shown in a table below and applied in case of proper lubrication or assembly and normal load.

Type of operating system	Major model number	Friction factor μ
Linear Motion Guide	H, S, M, MB	0.002 ~ 0.003
	R	0.001 ~ 0.002
Ball Spline	WLS, WSP	0.002 ~ 0.003
Super Ball Bushing / Linear Ball Bushing	SB, SBE, LM, LME	0.001 ~ 0.003
Cross Roller Guideway	WRG	0.001 ~ 0.0025

6 Precision

1. Precision Specification

The degree of travel of Linear Motion guide is measured as below. (See Figure 6)

- Tighten rail to the mounting surface of the bed using a bolt at the prescribed torque. (See Figure 6)
- Draw a measuring jig right up against the datum plane of the block as shown in Figure.
- Measure it by having the block and measuring jig travel the whole section from the starting point to the end point of the rail.
- The value measured by the measuring jig is the error in the parallelism of motion of the block.

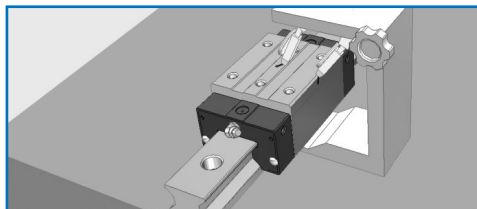

Figure 6. Parallelism of motion

Measuring the error in the degree of parallelization between the datum plane of block and that of rail

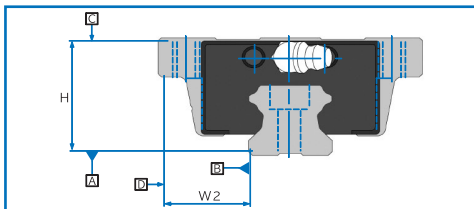

Figure 7. Difference of block

Difference between the maximum difference and minimum difference of blocks in each height and dimension installed to surface

2. Precision Design

Table 8. Classification of precision

Dimension	Terms
Dimension tolerance of height H	Distance from the base side of rail A to the top side of block C
Difference in height H	Difference in the height of blocks combined from each rail on the same plane
Dimension tolerance of width W ₂	Distance between the datum plane of rail B and the reference side of block D
Difference in width W ₂	Difference of the reference axis of rail B and the reference side of block D of blocks combined to the rail
Parallelism of motion of C against A	Change in the top side of block C based on the base side of rail A during the motion of block combined to the rail
Parallelism of motion of D against B	Change in the reference side of block D based on the reference side of rail B during the motion of block combined to the rail

3. Dimension Tolerance and Difference

Table 9. Specifications for precision of Linear Motion guide (H, S)

Unit : mm

Dimension	Terms	High	Precision	Super precision	Ultra precision
	No symbol	H P6	P P5	SP P4	UP P3
Dimension tolerance of height H	±0.080	±0.042	±0.020	±0.010	±0.008
Difference in height H	0.025	0.015	0.007	0.005	0.003
Dimension tolerance of width W ₂	±0.100	±0.050	±0.025	±0.015	±0.010
Difference in width W ₂	0.030	0.020	0.010	0.007	0.003
Parallelism of motion of C against A	See Table 10				
Parallelism motion of D against B	See Table 10				

Table 10. Length of rail and parallelism of motion of Linear Motion guide (H, S)

Unit : μm

Length of rail		Terms				
Above	Below	Moderate	High	Precision	Super precision	Ultra precision
		No symbol	P6	P5	P4	P3
—	50	5	3	2	1,5	1
50	80	5	3	2	1,5	1
80	125	5	3	2	1,5	1
125	200	5	3,5	2	1,5	1
200	250	6	4	2,5	1,5	1
250	315	7	4,5	3	1,5	1
315	400	8	5	3,5	2	1,5
400	500	9	6	4,5	2,5	1,5
500	630	11	7	5	3	2
630	800	12	8,5	6	3,5	2
800	1000	13	9	6,5	4	2,5
1000	1250	15	11	7,5	4,5	3
1250	1600	16	12	8	5	4
1600	2000	18	13	8,5	5,5	4,5
2000	2500	20	14	9,5	6	5
2500	3150	21	16	11	6,5	5,5
3150	4000	23	17	12	7,5	6

Table 11. Specifications for precision of Linear Motion guide (R)

Unit : mm

Dimension	High	Precision	Super precision	Ultra precision
	H	P	SP	UP
	P6	P5	P4	P3
Dimension tolerance of height H	± 0.042	± 0.020	± 0.010	± 0.008
Difference in height H	0.015	0.007	0.005	0.003
Dimension tolerance of width W_2	± 0.050	± 0.025	± 0.015	± 0.010
Difference in width W_2	0.020	0.010	0.007	0.003
Parallelism of motion of C against A	See Table 12			
Parallelism of motion of D against B	See Table 12			

Table 12. Length of rail and parallelism of motion of Linear Motion guide (R)

Unit : μm

Length of rail		Parallelism of motion			
Above	Below	High	Precision	Super precision	Ultra precision
		P6	P5	P4	P3
-	50	3	2	1,5	1
50	80	3	2	1,5	1
80	125	3	2	1,5	1
125	200	3,5	2	1,5	1
200	250	4	2,5	1,5	1
250	315	4,5	3	1,5	1
315	400	5	3,5	2	1,5
400	500	6	4,5	2,5	1,5
500	630	7	5	3	2
630	800	8,5	6	3,5	2
800	1000	9	6,5	4	2,5
1000	1250	11	7,5	4,5	3
1250	1600	12	8	5	4
1600	2000	13	8,5	5,5	4,5
2000	2500	14	9,5	6	5
2500	3150	16	11	6,5	5,5
3150	4000	17	12	7,5	6

Table 13. Specifications for precision of miniature Linear Motion guide (M, MB)

Unit : μm

Model No.	Dimension	Precision	Moderate	High	Precision
			Difference in height H	P6	P5
5	mension tolerance of height H		± 0.030	-	± 0.015
	Difference in height H		0.015	-	0.005
	Dimension tolerance of width W_2		± 0.030	-	± 0.015
	Difference in width W_2		0.015	-	0.005
	Parallelism of motion of C against A		See Table 14		
	Parallelism motion of D against B		See Table 14		
7	Dimension tolerance of height H		± 0.040	± 0.020	± 0.010
	Difference in height H		0.030	0.015	0.007
9	Dimension tolerance of width W_2		± 0.040	± 0.025	± 0.015
	Difference in width W_2		0.030	0.020	0.010
12	Dimension tolerance of width W_2		± 0.040	± 0.025	± 0.015
	Difference in width W_2		0.030	0.020	0.010
15	Parallelism of motion of C against A		See Table 14		
	Parallelism of motion of D against B		See Table 14		
20	Parallelism of motion of C against A		See Table 14		
	Parallelism of motion of D against B		See Table 14		

Table 14. Length of rail and parallelism of motion of miniature Linear Motion guide (M, MB Series) Unit : μm

Length of rail		Parallelism of motion			Length of rail		Parallelism of motion		
Above	Below	Moderate	High	Precision	Above	Below	Moderate	High	Precision
		No symbol	H P6	P P5			No symbol	H P6	P P5
-	40	8	4	1	820	850	24	14	5
40	70	10	4	1	850	880	24	14	5
70	100	11	4	2	880	910	24	14	5
100	130	12	5	2	910	940	24	14	5
130	160	13	6	2	940	970	24	14	5
160	190	14	7	2	970	1000	25	14	5
190	220	15	7	3	1000	1030	25	16	5
220	250	16	8	3	1030	1060	25	16	5
250	280	17	8	3	1060	1090	25	16	6
280	310	17	9	3	1090	1120	25	16	6
310	340	18	9	3	1120	1150	25	16	6
340	370	18	10	3	1150	1180	25	17	6
370	400	19	10	3	1180	1210	26	17	6
400	430	20	11	4	1210	1240	26	17	6
430	460	20	12	4	1240	1270	26	17	6
460	490	21	12	4	1270	1300	26	17	6
490	520	21	12	4	1300	1330	26	17	6
520	550	22	12	4	1330	1360	27	17	6
550	580	22	13	4	1360	1390	27	18	6
580	610	22	13	4	1390	1420	27	18	6
610	640	22	13	4	1420	1450	27	18	7
640	670	23	13	4	1450	1580	27	18	7
670	700	23	13	5	1480	1510	27	18	7
700	730	23	14	5	1510	1540	28	19	7
730	780	23	14	5	1540	1570	28	19	7
760	790	23	14	5	1570	1800	28	19	7
790	820	23	14	5					

4. Selection of Precision Class

Table 15. For the selection of precision class of Linear Motion guide by unit, please refer to the table below.

Application	Unit	Precision class					Preload		
		Moderate	High	Precision	Super precision	Ultra precision	Moderate	Light preload	Heavy preload
		No sigh	H P6	P P5	SP P4	UP P3	No symbol	G ₁	G ₂
Machine Tool	CNC shelf		•	•	•				•
	Machining center		•	•	•				•
	NC milling machine		•	•	•				•
	CNC tapping machine		•	•	•				•
	NC boring machine		•	•	•				•
	NC drilling machine		•	•	•				•
	3D engraving machine		•	•	•				•
	Jig boring machine		•	•	•				•
	EDM electric spark machine			•	•	•		•	•
	Grinding machine			•	•	•			•
Semiconductor equipment	Prober equipment					•		•	•
	Wire bonder				•	•		•	•
	Sliding machine				•	•		•	
	Dicing saw machine				•	•		•	
	IC test handler			•	•			•	
	PCB laser via-hole driller				•			•	
	PCB inspection equipment			•	•			•	
	Laser marker			•				•	
FPD	Chip mounter			•	•			•	
	Mac/Mic inspection equipment				•	•		•	
	Pattern test system				•	•		•	
	Exposure				•	•		•	
	Laser repair			•	•	•		•	
	Lighting test equipment		•	•				•	
	Coder equipment			•	•			•	
	Chip bonding equipment		•	•				•	
Dispenser equipment		•	•				•		

Application	Unit	Precision class					Preload		
		Moderate	High	Precision	Super precision	Ultra precision	Moderate	Light preload	Heavy preload
		No sigh	H P6	P P5	SP P4	UP P3	No symbol	G ₁	G ₂
FPD	Scriber		●	●				●	
	Glass edge grinding machine		●	●				●	
	FPD measuring/test equipment			●	●			●	
	Laminating equipment		●	●				●	
	Indentation test equipment								
	Prober equipment								
Industrial machine	Punching press		●					●	
	Tire molder	●						●	
	Tire valcanizer	●						●	
	Auto-shearing machine	●						●	
	Auto-welding machine	●					●	●	
	Conveyor	●					●		
	Textile machine	●					●		
	Injection molding machine	●					●	●	
Industrial robot	Cartesian coordinated robot	●	●	●				●	
	Gantry robot	●	●					●	
	LTR robot		●	●				●	
	Take-out robot	●						●	
	Cylindrical coordinated robot		●					●	
	Vacuum robot		●	●				●	
	Robot carriage	●						●	
	Linear actuator		●	●	●		●	●	
Others	Office machine	●					●		
	FA transport system	●					●		
	Medical equipment	●					●	●	
	Welding machine	●					●		
	Painting machine	●					●		
	Precision XY table		●	●	●			●	
	UVW stage		●	●				●	
	3D measuring machine			●	●	●		●	

7 Lubrication

1. Purpose

The purpose of lubricating Linear Motion guide is to create an oil film between rail, the raceway surface of block and a rolling element to avoid the direct contact of metals and reduce friction and wear, preventing the raceway surface and the rolling element from being overheated and melted to be adhered to each other.

Moreover, the oil film created between the raceway surface and a ball decreases load-induced contact stress to improve the rolling contact fatigue life and prevent rust.

Linear Motion guide is equipped with seal but grease inside the block is leaking little by little during the operation. Therefore it is required to lubricate it at a time and interval appropriate to each service condition.

2. Selection of lubricant

To achieve the best performance of Linear Motion guide, you have to select the lubricant suitable for service conditions.

Lubricants used for Linear Motion guide include grease and oil. You can select the lubricant and lubrication method that fit your service conditions, load, operating speed, assembly type, etc.

3. Grease lubrication

Grease is a semisolid lubricant consisting of base oil, thickener, and additives.

In case of using grease for Linear Motion guide, lithium soap grease is commonly used, but grease mixed with extreme-pressure additive is used under high load or according to use. If you want to use Linear Motion guide in a high-vacuum environment or a clean room, it's desirable to choose grease with excellent performance in low evaporation and low dust raise.

1) Refilling of grease

To refill grease to Linear Motion guide, supply a sufficient amount of grease through the nipple until remaining grease is discharged. It is appropriate to fill grease up to 50% of the volume of the block. To reduce rolling resistance which may increase after grease is filled, it is better to take a test run about 20 times prior to the operation.

2) Refill interval

If Linear Motion guide's travel exceeds a certain time, its lubricating performance declines. So it is required to refill an appropriate amount of grease at a proper time depending on service conditions and environment. Usually grease is to be filled when the travel distance reaches 100KM.

$$T = \frac{100 \times 6000}{V_e \times 60} \text{ hr}$$

T : Oil refilling cycle (time)
V_e : Velocity (m/min)

4. Oil lubrication

In case of using oil for Linear Motion guide, it is recommended to use oil lubricant with high viscosity (68mm²/sec) under higher load while oil lubricant with low-viscosity (13mm²/sec) at high velocity. It is appropriate to refill 0.3cm³ of oil per hour for each one block.

Table 16. Inspection and refilling time of lubricant

Type	Inspection item	Inspection period	Refilling time
Grease	<ul style="list-style-type: none"> Status of mixing with cutting chip, dust, foreign substance Status of contamination by other substances 	3~6 months	<ul style="list-style-type: none"> Generally 1-2 times per year Usually more than once per year if travel exceeds 100km/year Refill depending on the situation after checking the status of grease
Oil	Lubricant quantity, contamination, foreign substance	3~6 months	<ul style="list-style-type: none"> Refill depending on the results of inspection, and determine the optimal amount to refill depending on the capacity of oil tank
	Check oil level (supply oil mist)	Before every operation	<ul style="list-style-type: none"> Refill an appropriate amount after identifying the consumption Standardize the optimal amount after identifying the consumption

※ Please do not use oil that may affect synthetic resin which is the material of Linear Motion guide units.

Table 17. Lubricants used for Linear Motion guide

Application	Main use	Product name	Manufacturer	Temp. in use (°C)	Base oil	Type of thickener
Common use (extreme-pressure additive incl.)	Industrial machine, machine tool	Albania EP2 NIGACE AFC	SHELL NTG	-20 ~ +110	Mineral oil	Lithium
Common use	Machine tool, electric spark machine, industrial robots, etc.	Albania S2 NIGACE AFC	SHELL NTG	-25 ~ +120 -54 ~ +170	Mineral oil Synthetic oil	Lithium Urea
Clean & low dust raise	Semiconductor, FPD equipment	SNG 5050 DEMNUM	NTG DAIKIN	-40 ~ +1200 -50 ~ +300	Synthetic oil	Urea
Eco-friendly	Semiconductor AMOLED process equipment, driving gear in vacuum chamber	FOMBLIN Krytox High vacuum grease	AUSIMONT DuPont Dow Corning	-20 ~ +250	Synthetic oil	Ethylene fluorinated
Machine tool	Excellent in preventing rust and oil film strength Suitable for machine tools because it is hardly emulsified to clearance	VACTRA No.2 SLC DTE Oil	Exxon Mobil	-20 ~ +100	Oil	Way oil Turbine oil
Special use	Corrosion proofing	6459 Grease	SHELL	-20 ~ +100	Mineral oil	Polyurethane

8 Surface Treatment

1. Surface Treatment

WON ST uses the following methods for the optimal treatment of surfaces of Linear Motion guide in order to prevent rust and enhance appearance.

2. Types of Surface Treatment

1) Electrolytic rust-preventive black coating (black Cr plating)

This is an industrial black chrome coating which is used to improve the corrosion resistance at low cost. It can achieve better corrosion resistance than martensite stainless steel and be used to enhance appearance and prevent the reflection of light.

2) Industrial hard Cr plating

The film's hardness is over 850HV so its wear resistance is excellent and the corrosion resistance is comparable with that of martensite stainless steel.

WON ST offers surface treatments such as alkakine coloring or color alumite treatment if a customer requests. If you want use Linear Motion Guide by treating its surface, you have to set the safety factor high.

3) Fluoride low-temperature Cr plating

It is also called "Raydent." This is a combined surface treatment of black Cr coating with special fluoride resin coating which is used in where corrosion resistance or low dust raise is needed - for instance clean room.

9 Dust Proof

1. Dust Proof

To make use of the characteristics and performance of Linear Motion guide, it is important to protect the unit from external foreign substances which are likely to cause abnormal wear or shorten life. If dust or foreign substance is expected to be mixed in, it is required to use the effective sealing or dust-proofing system.

2. Types of Dust Proof

WON Linear Motion guide is basically equipped with seal but if a customer request, a metal scraper can be additionally mounted on the unit before shipment.

1) Exclusive seal

The block is equipped with end seals, side seals and inner seals to protect the bearing from foreign substances.

2) Metal scraper

A metal scraper is installed outside the end seals and effective in preventing foreign substances such as hot spatter or slag created during a welding process from entering into the unit.

10 Measure to Use in Special Environment

WON Linear Motion guide is useful in various special applications if being used in accordance with service conditions including material, surface treatment, dust proof, grease, etc.

Table 18.

Type of lubricants	Details	Details	
Clean (clean room) - Semiconductor, FPD, medical equipment -	• If used in a clean environment, dust or particles generated in Linear Motion guide should be minimized.	Lubricant	• For use in a clean environment • Use low dust raise grease
		Rust prevention	• Black Cr coating • Fluoride low-temperature colorimetric Cr plating (Raydent treatment) • Use high-corrosion resistant stainless steel as material
Vacuum - Semiconductor, FPD deposition equipment –	• If used in a vacuum environment, out gas discharged from Linear Motion guide should be tightly controlled to maintain the vacuum status. • Great rust prevention is required since rust-prone parts cannot be used in this environment.	Lubricant	• Use grease for a vacuum environment
		Rust prevention (Out Gas)	• Use high-corrosion resistant stainless steel as material • Use a self oiling agent using special coatings such as fluoroplastic coating • Use ceramic as material
High-temperature environment	• If used in higher temperature than general environment, the material's heat resistance is important and plastic synthetic resin used for parts should be replaced with metal.	Lubricant	• Use grease for high-temperature environments
		Material	• Use an end seal, side seal + double seal • Use a double seal • Use a special seal for high temperature
Dust	• If used in an environment filled with cutting chips, wood dust, and dust, it is required to develop a measure to protect the block from foreign substances.	seal	• Use a plastic synthetic resin cap • Use a metal cap • Use a metal scraper
		Cap	• Use a plastic synthetic resin cap • Use a metal cap • Use a seal plate
		Holding door	• Use an exclusive holding door • Use an sealing all-in-one holding oor
Spatter	• If exposed to a spot welding or arc welding environment, hot spatters may be fixed onto the	Spatter	• Fluoride black Cr coating
		seal	• Use a metal scraper
		Dust proof	• Use a metal cap • Use a seal plate

11 Placement and Installation

1. Placement and Structure

To place Linear Motion guide in the equipment, first identify the overall structure of the equipment, then check the size of the base and a transfer table and consider load applied according to mounting directions such as placing vertically, in slope, or in the back as well as required life to make sure Linear Motion guide is optimally installed.

Placement of Linear Motion guide (example)

(1) Assembly of the top side of block, block transfer



(2) Assembly of the back side of block, rail transfer



(3) Assembly of the flank of block, block transfer



(4) Assembly of the flank of block, rail transfer



(5) Assembly of the wall side of block, rail transfer

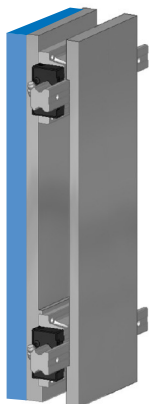

(6) Assembly of the wall side of block, block transfer

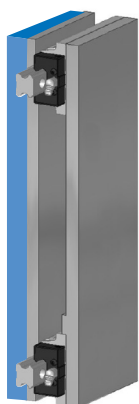

(7) Symmetrical assembly of the top and bottom of block, rail transfer

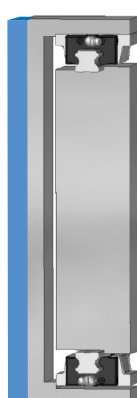

(8) Symmetrical assembly of the top and bottom of block, block transfer



2. Mounting and Fixation

In the structure that vibration or impact is applied or where combined load or moment load is applied, Linear Motion guide should be fixed in a different way from a general method.

As a widely used method, push a pressure plate from the flank after slightly protruding the block and rail of LM unit.

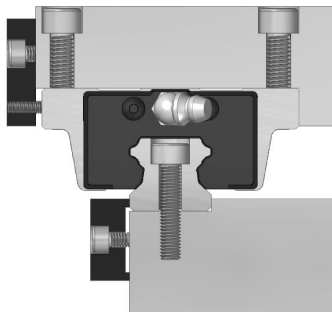

Figure 8. Pushing a pressure plate from the flank

Fasten a tapered fixture with a bolt. Even slight bolting up generates big force in a horizontal direction. If it is bolted up too much, deformation may occur in rail, for instance, which needs to be taken a caution.

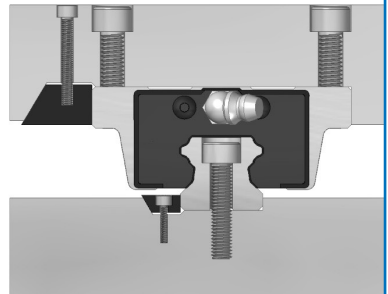

Figure 9. Pushing a tapered plate

Need to use miniature bolts due to space constraint when pushing the rail and useful if having many bolts for pushing.

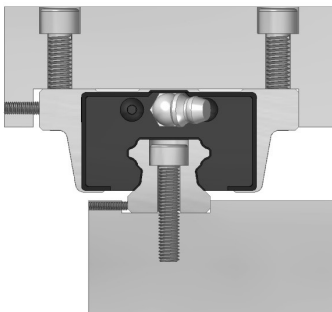

Figure 10. Pushing a bolt from the flank

Push a needle roller with the head of a counter-sunk screw using a roller of the bed. You must be careful to push it to fit the screw.

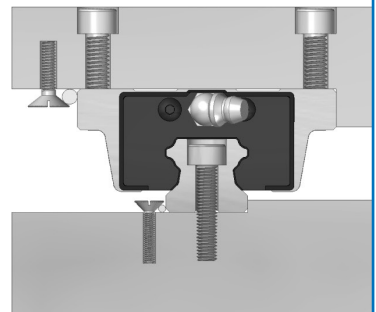

Figure 11. Pushing a roller

3. Design of mounting surface during installation

Design and management of mounting surface

The precision of mounting surface of Linear Motion guide and the error in installation generate unexpected load and stress to the unit, therefore it is required to take caution to prevent the harmful effects on the unit's travel and life.

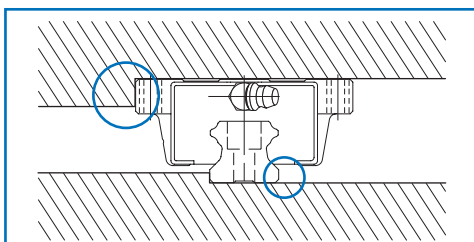

Figure 12. Shape of edges

Management of vertical angle of datum plane for installation

If the vertical angle of the installation surface and of a rail or a block is inaccurate, it cannot be assembled precisely. So you need to review the vertical angle and error during design.

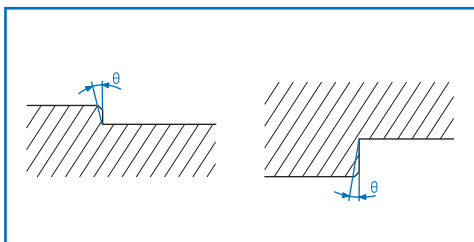

Figure 13.

Management of datum plane for assembly

It is important to manage the height and thickness of datum plane during design.

If the height is too high or low, a rail or a block cannot be assembled precisely due to its surface attachment. Or the application of eccentric load, horizontal load and moment load may loosen the strength of joint and result in faulty assembly which will be unable to meet the precision requirements. So attention must be paid

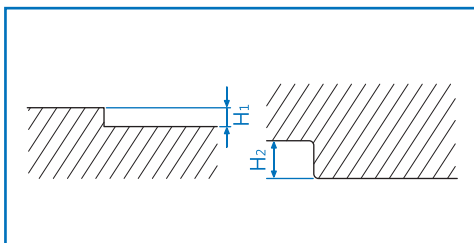

Figure 14. Vertical angle of contact datum plane

Management of the shape of contact corner

If the right-angled corner of a rail or a block installed to the mounting surface of Linear Motion guide is processed in R-shape and R value is bigger than the dimension of the surface of the rail or the block, it may not be assembled precisely to the datum plane. So attention must be paid.

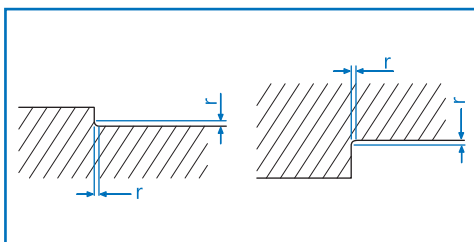

Figure 15. Dimension of contact datum plane

Management of dimensional tolerance between datum plane and bolt during design

If the dimensional tolerance from the contact datum plane to the mounting hole of a rail or a block of Linear Motion guide is too big, precise assembly is impossible so attention must be paid.

Generally the dimensional tolerance is $\pm 0.1\text{mm}$.

If the distance tolerance from the assembly datum plane to the assembly bolt roll of a rail and a block is too wide or narrow, precise assembly is impossible. So the tolerance must be $W3 \pm 0.1\text{mm}$ during design.

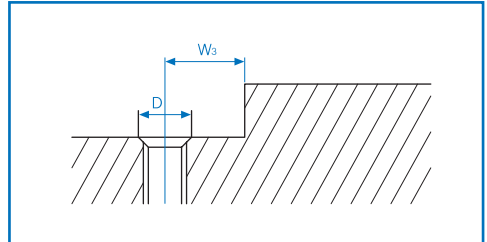

Figure 16. Dimensional tolerance between contact datum plane and mounting hole

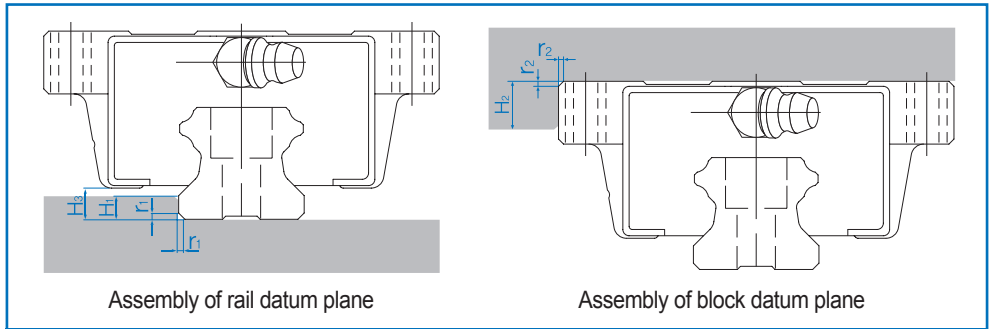

Figure 17. Height of the raised spot of mounting surface and radius of corner R

- Make a datum plane which can contact the flank in order to secure convenience in assembly of and precision positioning of a rail and a block during the installation of Linear Motion guide.
- The height of the raised spot of contact datum plane or the radius of corner may vary depending on the specifications of Linear Motion guide so please see the table below.
- To prevent deformation of the raised spot by pressing force from above or pushing force from side, sufficient thickness must be secured during design.

H Series

Unit : mm

Model No.	Radius of corner of the installation to rail $r_1(\text{max.})$	Radius of corner of the installation to block $r_2(\text{max.})$	Height of raised spot of the installation to rail H_1	Height of raised spot of the installation to block H_2	H_3
15	0.5	0.5	3	4	4.7
20	0.5	0.5	3.5	5	5
25	1	1	5	5	7
30	1	1	5	5	7.5
35	1	1	6	6	9
45	1	1	8	8	10
55	1.5	1.5	10	10	13

S Series

Unit : mm

Model No.	Radius of corner of the installation to rail r_1 (max.)	Radius of corner of the installation to block r_2 (max.)	Height of raised spot of the installation to rail H_1	Height of raised spot of the installation to block H_2	H_3
15	0.5	0.1	2.5	4.0	4.5
20	0.5	1.0	4.0	5.0	6.0
25	1.0	1.0	5.0	5.0	7.0

M Series, MB Series

Unit : mm

Model No.	Radius of corner of the installation to rail r_1 (max.)	Radius of corner of the installation to block r_2 (max.)	Height of raised spot of the installation to rail H_1	Height of raised spot of the installation to block H_2	H_3
5	0.2	0.2	0.8	2	1
7	0.2	0.2	1.2	2.5	1.5
9	0.2	0.2	1.5	3	2
12	0.2	0.2	2.5	4	3
15	0.2	0.2	3	4.5	4
20	0.2	0.2	4	5	5

R Series

Unit : mm

Model No.	Radius of corner of the installation to rail r_1 (max.)	Radius of corner of the installation to block r_2 (max.)	Height of raised spot of the installation to rail H_1	Height of raised spot of the installation to block H_2	H_3
35	1	1	5	6	6.5
45	1.5	1.5	6	8	8
55	1.5	1.5	8	10	10

4. Error tolerance of mounting surface during installation

1) Auto-adjusting and error-absorbing abilities

Linear Motion guide has an excellent auto-adjusting ability so that even though the structure to be assembled to a rail is slightly deformed or processing error may occur, the straightness or parallelism of a table after assembly will be better than the precision in processing before assembly and the quite straight-line running is available.

2) Error tolerance of the degree of parallelization when using 2-axis assembly (P_1)

The error in the degree of parallelization when using a 2-axis assembly is as shown below.

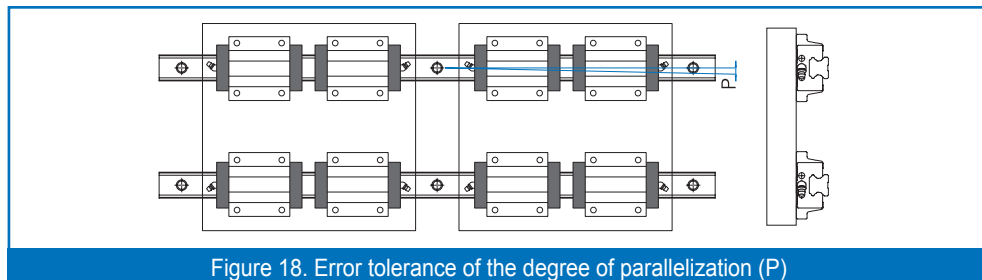

Figure 18. Error tolerance of the degree of parallelization (P)

H Series

Unit : μm

Model No.	Common clearance	G ₁ clearance	G ₂ clearance
15	25	18	-
20	25	20	18
25	30	22	20
30	40	30	27
35	50	35	30
45	60	40	35
55	70	50	45

S Series

Unit : μm

Model No.	Common clearance	G ₁ clearance	G ₂ clearance
15	25	18	-
20	25	20	18
25	30	22	20

M Series, MB Series

Unit : μm

Model No.	Common clearance	G ₁ clearance
5	2	-
7	3	-
9	4	3
12	9	5
15	10	6
20	13	8

R Series

Unit : μm

Model No.	Common clearance	G ₁ clearance	G ₂ clearance
35	14	10	7
45	17	13	9
55	21	14	11

3) Error tolerance of height during 2-axis assembly (P_2)

If the error in height is too big, the block may be distorted and its rigidity may be affected as the raceway groove of the block and the contact angle of a ball or a roller which is the rolling element are altered.

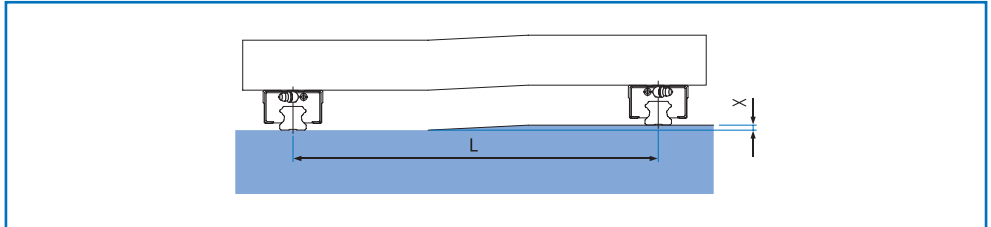

Figure 19. Error tolerance of height level in 2-axis (X)

H Series, S Series

Unit : μm

Model No.	Common clearance	G ₁ clearance	G ₂ clearance
15	0.26L	0.17L	-
20	0.26L	0.17L	0.10L
25	0.26L	0.17L	0.14L
30	0.34L	0.22L	0.18L
35	0.42L	0.30L	0.24L
45	0.50L	0.34L	0.28L
55	0.60L	0.42L	0.34L

M Series, MB Series

Unit : μm

Model No.	Common clearance	G ₁ clearance
5	0.04L	-
7	0.05L	-
9	0.07L	0.01L
12	0.10L	0.02L
15	0.12L	0.04L
20	0.14L	0.06L

R Series

Unit : μm

Model No.	Common clearance	G ₁ clearance	G ₂ clearance
35, 45, 55	0.22L	0.17L	0.12L

The error tolerance of height level in using 2-axis Linear Motion guides is as follows.

5. Marking of datum plane during installation

The datum plane of WON ST's Linear Motion guide is the ground surface on the opposite side of WON mark shown in the block.

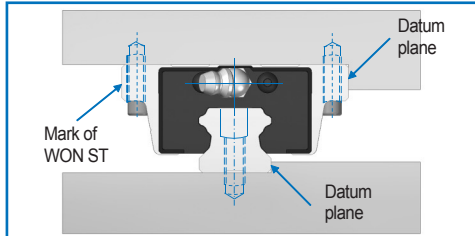

Figure 20. Linear Motion guide on the reference axis

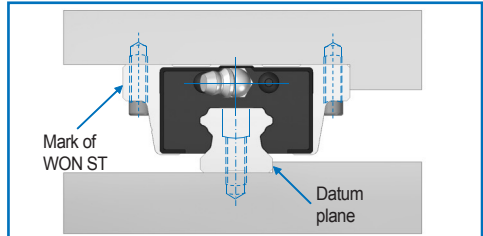

Figure 21. Linear Motion guide on the driven shaft

6. Connection of rails

If you need a longer rail than the one supplied, you can connect rails for the purpose of use. The mark on the rail indicates the point where rails should be linked.

If the block passes through the connecting points simultaneously, they may affect the unit's travel and cause a delicate hitch. To solve this problem, it is recommended to make sure the connecting points intercrossed

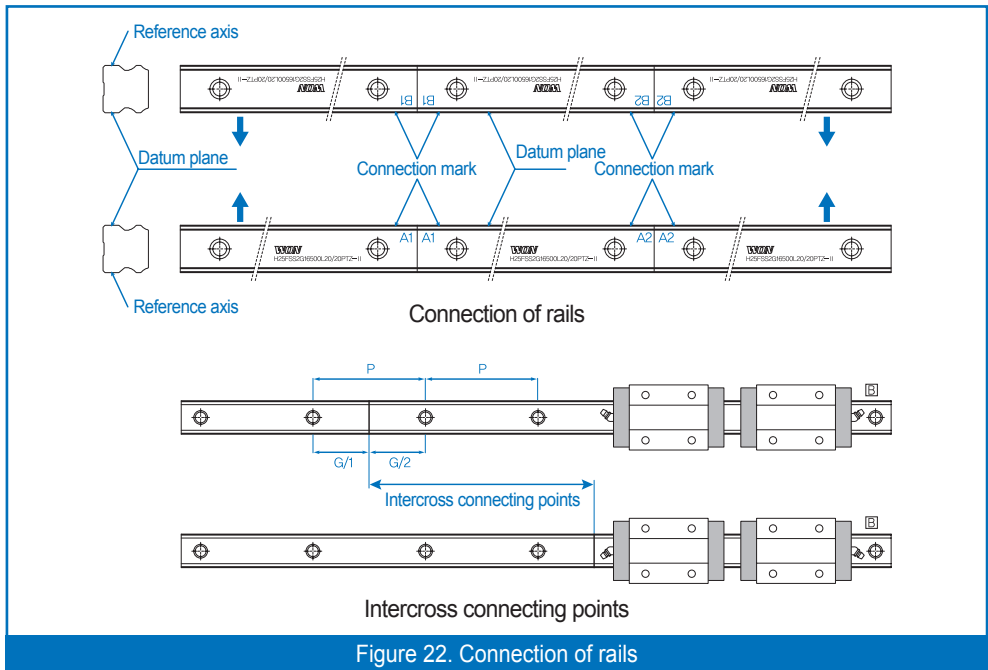
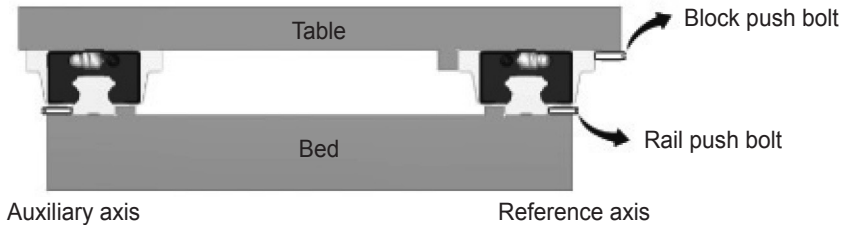

Figure 22. Connection of rails

7. Installation of Linear Motion Guide

1. Installation of Linear Motion guide in the equipment exposed to vibration and impact



1) Install a rail

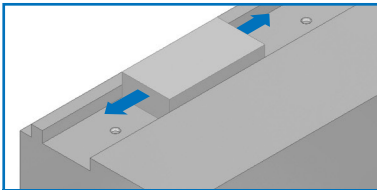

Step 1: Check the surface to be installed with a rail

Prior to installation, thoroughly remove burr, dust, rust preventive oil, etc.

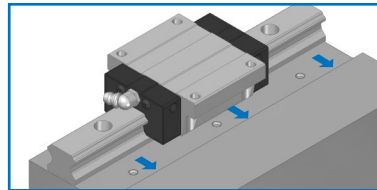

Step 2: Draw a rail tightly to the datum plane

Gently place LM guide on the bed and push it in the opposite direction of the bed's datum plane

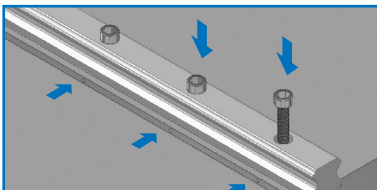

Step 3: Fasten bolts temporarily

Check the status of bolts and fasten every bolt temporarily

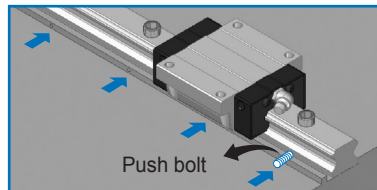

Step 4: Fasten push bolts

Fix push bolts to make sure that the rail is parallel with the datum plane of the bed.

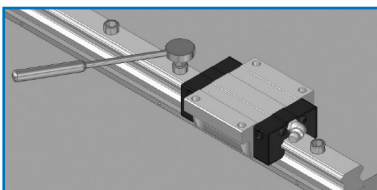

Step 5: Fix and fasten assembly bolts using a torque wrench

· Step 5 :
Fasten all bolts using the recommended torque.
Fasten the bolt in the center first and then continue fastening each bolt toward both ends in order to maintain the precision of rail during assembly.

· Step 6 : Assemble an auxiliary axis
Repeat the procedure above for the installation of an auxiliary axis.

2) Install a block

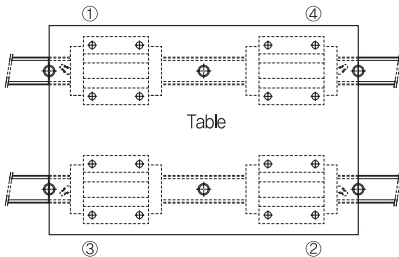

- Step 1: Assembly bolts temporarily

Place a table on the block and fasten all bolts temporarily

- Step 2: Fasten bolts tightly

Fix the main rail block to the opposite side of the table's datum plane using a push bolt and adjust the position of the table.

- Step 3: Fix and fasten assembly bolts

Completely fasten all bolts on the datum plane and subsidiary side in the order of 1 to 2.

2. Installation of Linear Motion guide without a push bolt

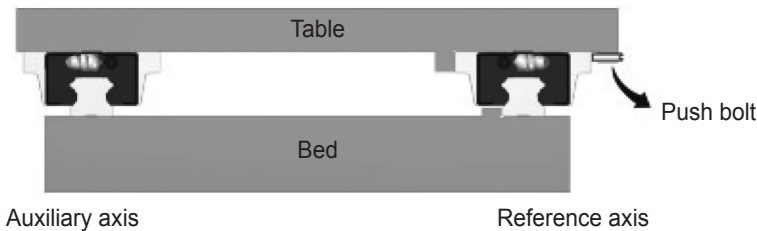

1) Install a master rail

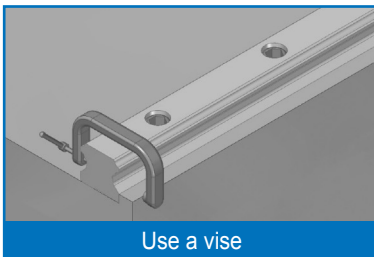

Fasten bolts temporarily and push a master rail toward the datum plane using a C-vise. Fasten the bolts according to the prescribed torque and order.

2) Install an auxiliary rail

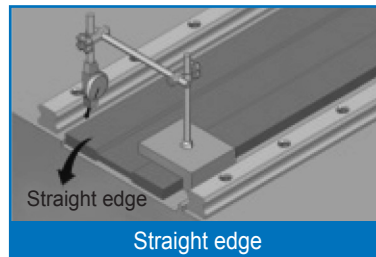

Place a straight edge between two rails and make sure it is parallel with the master rail that is fixed temporarily.

Check the degree of parallelism with the dial gauge and adjust the rail if needed. Then, fasten bolts in order.

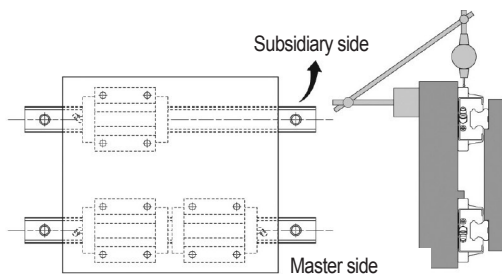

- Assembly using a table

1. Fix two blocks on the datum plane and one block on the subsidiary side to a table.
2. Fix another auxiliary block and rail to the table and bed temporarily.
3. Place a dial gauge on the table and make sure a probe of the gauge contact the subsidiary side of the block.
4. Separate the table from the end of the rail and check the degree of parallelization of the block with the auxiliary rail.
5. Fasten bolts in order.

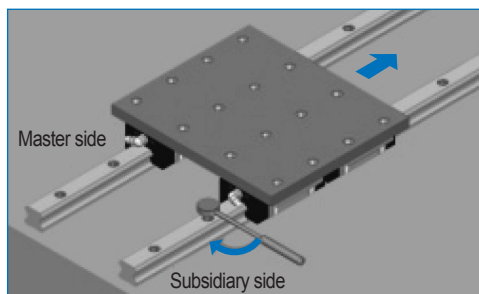

- Assembly using a rail on the datum plane

1. Fix two blocks on the datum plane and one block on the subsidiary side to a table.
2. Fix another auxiliary block and rail to the table and bed temporarily.
3. Separate the table from one rail and make an adjustment by considering the rolling resistance during the movement and checking the degree of parallelization of the auxiliary rail.
4. Fasten bolts in order.

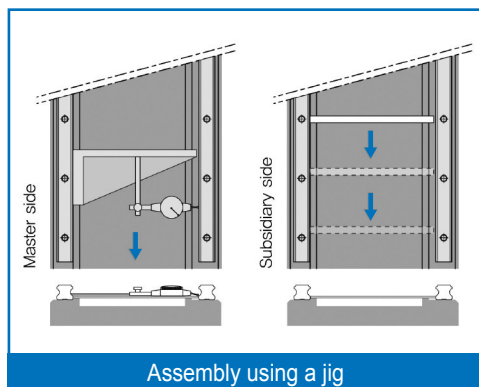

Assembly using a jig

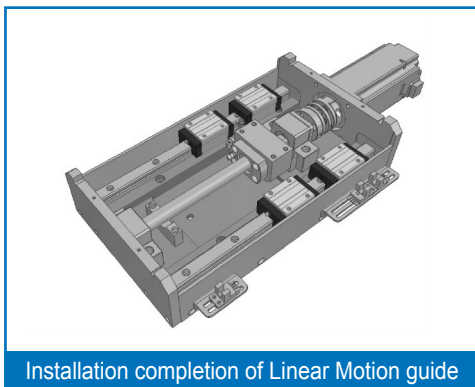

Installation completion of Linear Motion guide

Move the position of a block in every bolt pitch at the end of the rail in consecutive order and fasten bolts in order by adjusting the degree of parallelism between the datum plane of a reference rail and that of an auxiliary rail using a special jig.

3. Installation of Linear Motion guide without the datum plane for a reference rail

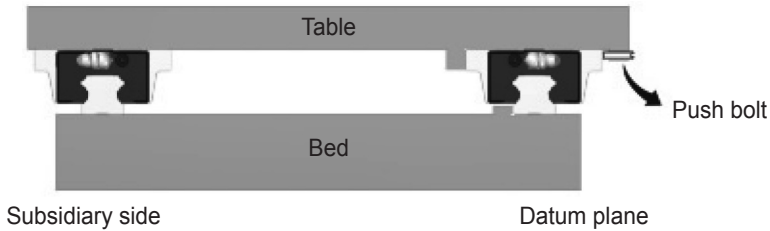

1) Install a reference rail

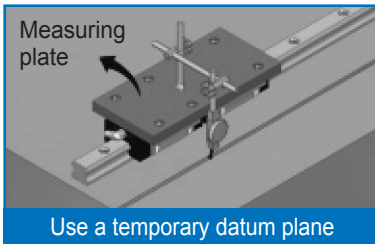

Fix two blocks together onto the measuring plate and install the temporary datum plane near the surface where a rail is to be installed on the bed. Then check and adjust the degree of parallelism of the rail and fasten bolts in order.

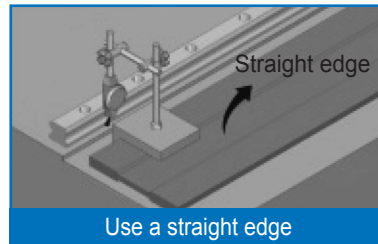

Fix a rail to the bed temporarily and adjust it to be straight using a dial gauge and then fasten bolts in order.

2) Apply the same method when installing the auxiliary block and rail

4. Measure precision after installation

You can check the precision of travel by fixing two blocks onto the measuring plate. Use a dial gauge with a straight edge or a laser interferometer to measure the precision.

In case of using a dial gauge, you have to place the straight edge as close to the block as possible in order to accurately measure it.

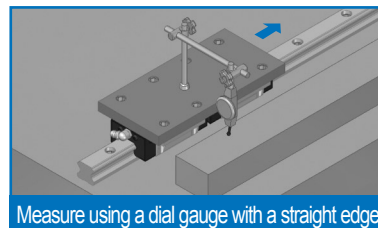
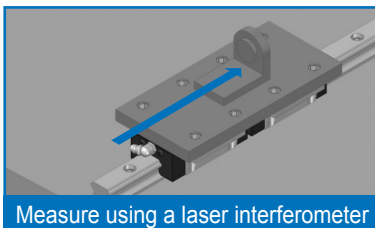

8. Torque used to fasten bolts during the assembly of Linear Motion guide

1) Select the optimal torque for bolts

For the assembly of the rail of Linear Motion guide, the optimal clamping torque must be used depending on the materials of mounting surface or bolts. Inaccurate clamping torque may affect the mounting precision of the rail so please use a torque wrench.

2) Recommended torques by the material of mounting base of Linear Motion guide

Unit : N·m

Bolt specification	Torque value (Unit : N·m)		
	Steel	Casting	Aluminum
M3	2	1.3	1
M4	4	2.7	2
M5	8.8	5.9	4.4
M6	13.7	9.2	6.8
M8	30	20	15
M10	68	45	33
M12	120	78	58
M14	157	105	78
M16	196	131	98
M20	382	255	191

3) Recommended torques by the material of bolts

Unit : N·m

Bolt specification	Clamping torque		Bolt specification	Clamping torque	
	Carbon steel bolt	SCM steel bolt		Carbon steel bolt	SCM steel bolt
M2.3	-	0.4	M12	108	76
M2.5	-	0.6	M14	172	122
M3	1.7	1.1	M16	263	196
M4	4.0	2.5	M18	-	265
M5	7.9	5.1	M20	512	-
M6	13.3	8.6	M24	882	-
M8	32.0	22.0	M22	-	520
M10	62.7	43.0	M30	1750	-

9. Directions of bolt fastening by Linear Motion guide type

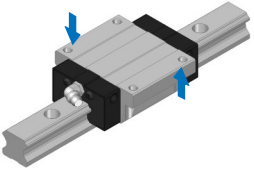
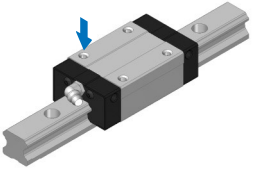
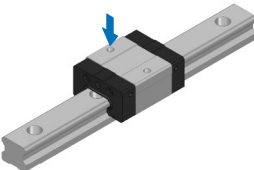
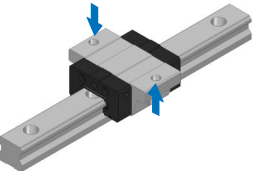
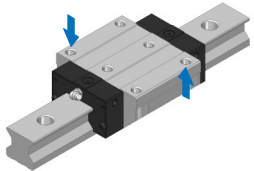
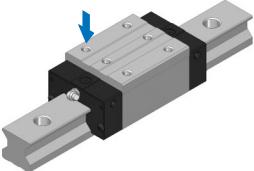
	<p style="text-align: center;">H-F, H-FL</p> <p>Since the flange of a block is tapped and the counter bore is processed in the bottom, bolts can be assembled both from bottom to top and from top to bottom as indicated by arrows. But, if bolts are fastened from bottom to top, it is recommended to use one size smaller bolts.</p>
	<p style="text-align: center;">H-R, H-RL</p> <p>Since tap is processed in the square body of the block, it is used when bolts are fastened from top to bottom as indicated by arrows.</p>
	<p style="text-align: center;">S-C, S-R</p> <p>Since tap is processed in the rectangular body of the block, it is used when bolts are fastened from top to bottom as indicated by arrows.</p>
	<p style="text-align: center;">S-CF, S-F</p> <p>Since the flange of a block is tapped and the counter bore is processed in the bottom, bolts can be assembled both from bottom to top and from top to bottom as indicated by arrows. But, if bolts are fastened from bottom to top, it is recommended to use one size smaller bolts.</p>
	<p style="text-align: center;">R-F, R-FL</p> <p>Since the flange of a block is tapped and the counter bore is processed in the bottom, bolts can be assembled both from bottom to top and from top to bottom as indicated by arrows. But, if bolts are fastened from bottom to top, it is recommended to use one size smaller bolts.</p>
	<p style="text-align: center;">R-R, R-RL</p> <p>Since the rectangular body of a block is tapped, it is used when bolts are fastened from top to bottom as indicated by arrows.</p>

12 Types of Linear Motion Guide

1. Linear Motion Guide H Series

1) Structure of H Series

WON Linear Motion Guide H Series has a four-row circular arc-groove structure in the raceway groove of a rail or a block and is a 4-direction equal load type which can bear equal load rating for vertical compression load, tensile load, and horizontal load as the rolling element is combined with balls at 45 degree, which reduces friction resistance to ensure smooth motion and long life.

Also if the ball is preloaded, it can enhance the rigidity of Linear Motion guide and minimize Linear Motion guide's displacement for external load.

2) Features of H Series

- a. High quality and very effective in realizing high precision and elimination of labor
- b. High rigidity and high precision which can realize the stable travel for a longtime
- c. Great wear resistance and friction resistance which ensures a long life
- d. Great auto-adjusting and error-absorbing abilities with the face-to-face duplex structure same to D/F combination of ball bearing
- e. Various specifications for easy design
- f. Easy to use due to great compatibility between a rail and a block

Linear Motion Guide H Series

Ball Linear Motion Guide

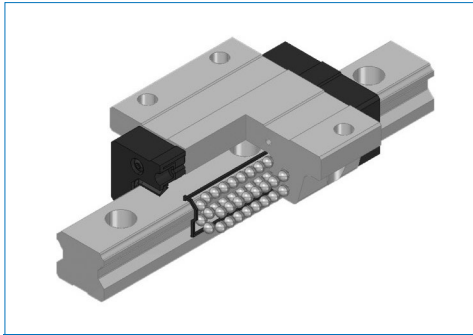

H Series (Full-ball Type)

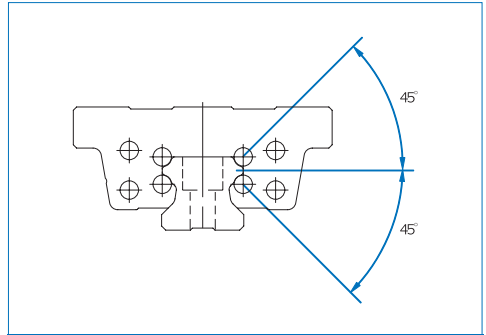

Cross Section

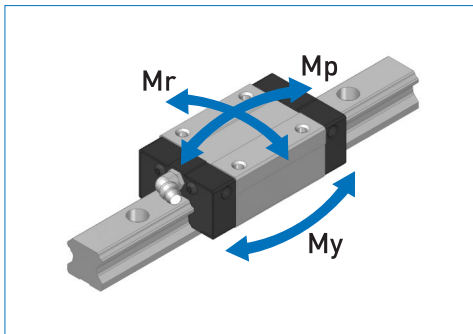

Moment Rigidity

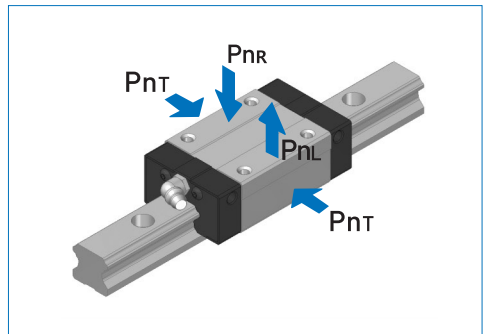

Radial Rigidity

Types and Features

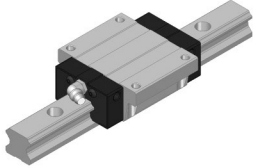
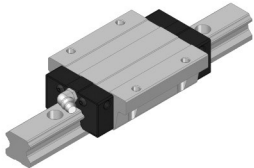
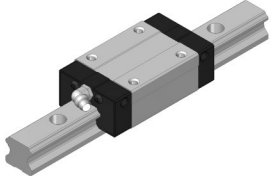
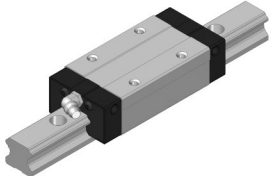
Category	Type	Shape & Features		
Flange type	H-F		<ul style="list-style-type: none"> - With the tapped flange of a block, a general type which can be assembled both from bottom to top and from top to bottom - A 4-direction equal load type with high rigidity and high load 	Machine tool X, Y, Z axis, CNC machining center, CNC shelf, CNC tapping center, Electric injection machine, 3D engraving machine, laser processor, milling machine, welder for exclusive use, EDM electric spark machine, automation device, Various transport system, FPD inspection equipment,
	H-FL		<ul style="list-style-type: none"> - Having the cross section identical to that of H-F Series, it increased load rating by extending the whole length (L1) of LM guide block - A 4-direction equal load type with high rigidity and high load 	
Compact type	H-R		<ul style="list-style-type: none"> - With the tapped top side of a block, a compact type that the width of LM guide block is minimized - A 4-direction equal load type with high rigidity and high load 	Various transport system, FPD inspection equipment, Industrial robots, ATC, Precision X-Y table, Various industrial machine
	H-RL		<ul style="list-style-type: none"> - Having the cross section identical to that of H-R Series, it increased load rating by extending the whole length (L1) of LM guide block - A 4-direction equal load type with high rigidity and high load 	

Standard and maximum length of a rail

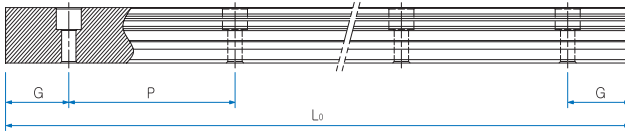

Unit : mm

Model No.	H15	H20	H25	H30	H35	H45	H55
Standard length	160	160	220	280	440	570	780
	220	220	280	360	520	675	900
	280	280	340	440	600	780	1020
	∴	340	400	520	680	885	∴
	1360	∴	460	600	760	∴	2820
	1480	1960	∴	∴	∴	2880	2940
	1600	2080	2200	2520	2680	2985	3060
		2200	2320	2680	2840	3090	
		2440	2840	3000			
			3000				
Standard pitch P	60	60	60	80	80	105	120
G	20	20	20	20	20	22.5	30∴
Max. length	4000						

Standard tap hole type of a rail

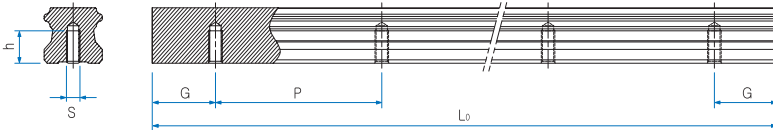

Model No.	S	h(mm)
H15	M5	8
H20	M6	10
H25	M6	12
H30	M8	15
H35	M8	17
H45	M12	24
H55	M14	24

H-F Series, H-FL Series

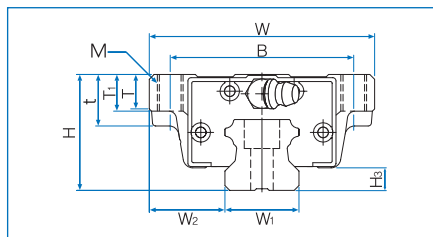
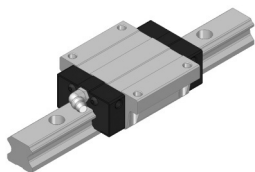

Model No.	External dimensions			Dimensions of block										Grease nipple	H ₃
	Height H	Width W	Length L	B	C	M	L ₁	t	T	T ₁	N	E			
H 15F	24	47	57	38	30	M5	40,8	–	7	11	6	6	A-M4	4,7	
H 15FL	24	47	65,3	38	30	M5	49,1	–	7	11	6	6	A-M4	4,7	
H 20F	30	63	72,7	53	40	M6	53,1	–	9,2	10	7,5	12	B-M6F	6	
H 20FL	30	63	88,6	53	40	M6	69	–	9,2	10	7,5	12	B-M6F	6	
H 25F	36	70	83	57	45	M8	58,3	–	11,5	16	9	12	B-M6F	7	
H 25FL	36	70	102,9	57	45	M8	78,2	–	11,5	16	9	12	B-M6F	7	
H 30F	42	90	97,8	72	52	M10	70,8	–	9,5	18	7,3	12	B-M6F	7,5	
H 30FL	42	90	120	72	52	M10	93	–	9,5	18	7,3	12	B-M6F	7,5	
H 35F	48	100	110	82	62	M10	80,8	–	12,5	21	8	12	B-M6F	9	
H 35FL	48	100	135,4	82	62	M10	106,2	–	12,5	21	8	12	B-M6F	9	
H 45F	60	120	139	100	80	M12	101,9	25	13	15	10	16	B-PT1/8	10	
H 45FL	60	120	170,8	100	80	M12	133,7	25	13	15	10	16	B-PT1/8	10	
H 55F	70	140	163	116	95	M14	117,5	29	19	17	11	16	B-PT1/8	13	
H 55FL	70	140	201,1	116	95	M14	155,6	29	19	17	11	16	B-PT1/8	13	

Composition of Model No.

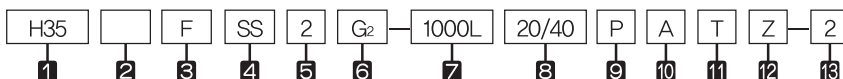

- 1 Model No. of Linear Motion Guide
 - 2 Type of block : **No symbol**–Full-ball type / **S**–Spacer retainer type
 - 3 Form of block : **R**–Rectangular standard type / **RL**–Rectangular long type / **F**–Flange standard type / **FL**–Flange long type
 - 4 Type of seal : **UU**–End seal / **SS**–End seal + Inside seal / **ZZ**–End seal + Inside seal + metal scraper (*1)
 - 5 Number of blocks combined in 1 rail
 - 6 Symbol of clearance : **No symbol**–Normal preload / **G₁**–Light preload / **G₂**–Heavy preload / **G_s**–Special preload (*2)
 - 7 Length of rail
 - 8 Size of G value : standard G value has no symbol.
 - 9 Symbol of precision : **No symbol**–Moderate precision / **H**–High precision / **P**–Precision / **SP**–Super Precision / **UP**–Ultra Precision (*3)
 - 10 **No symbol**–Rail counter bore type (A topside assembly) / **A**– Rail tap hole type (an underside assembly) (*4)
 - 11 Connection symbol
 - 12 Special symbol
 - 13 Number of axis used on the same surface
- (*1) See P77 Symbol List of Optional Parts (*2) See P17 Radial Clearance
 (*3) See P24 Selection of Precision Class (*4) See P47 Standard tap hole type of a rail

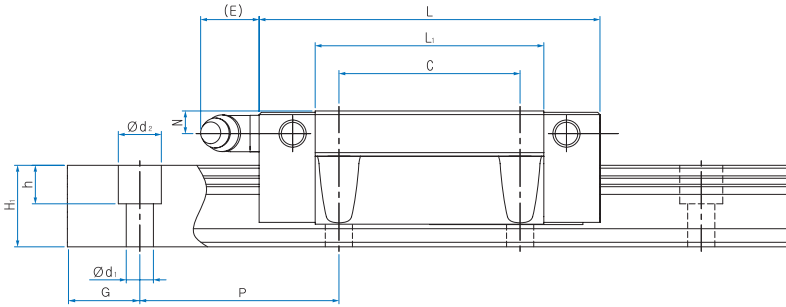

Unit : mm

Dimensions of Rail						Basic load rating		Static allowance moment kN-m					Mass	
Width W ₁ ±0.05	W ₂	Heigh H ₁	Value G	Pitch P	d ₁ x d ₂ x h	C kN	C ₀ kN	M _p		M _y		M _r	Block kg	Rail kg/m
								1	2(contact)	1	2(contact)	1		
15	16	13	20	60	4,5X7,5X5,3	9,9	16,2	0,115	0,552	0,115	0,552	0,129	0,19	1,3
15	16	13	20	60	4,5X7,5X5,3	11,2	19,3	0,165	0,769	0,165	0,769	0,154	0,24	1,3
20	21,5	16,5	20	60	6X9,5X8,5	14,9	23,9	0,221	1,049	0,221	1,049	0,251	0,41	2,2
20	21,5	16,5	20	60	6X9,5X8,5	17,8	30,7	0,370	1,692	0,370	1,692	0,322	0,54	2,2
23	23,5	20	20	60	7X11X9	22,1	33,1	0,337	1,636	0,337	1,636	0,398	0,61	3,0
23	23,5	20	20	60	7X11X9	26,8	43,6	0,596	2,760	0,596	2,760	0,525	0,82	3,0
28	31	26	20	80	9X14X12	38,4	57,1	0,711	3,384	0,711	3,384	0,828	1,1	4,85
28	31	26	20	80	9X14X12	45,9	73,6	1,203	5,506	1,203	5,506	1,067	1,3	4,85
34	33	29	20	80	9X14X12	51,1	74,6	1,062	5,012	1,062	5,012	1,298	1,6	6,58
34	33	29	20	80	9X14X12	61,0	96,2	1,797	8,172	1,797	8,172	1,674	2,01	6,58
45	37,5	38	22,5	105	14X20X17	82,1	116,4	2,860	9,912	2,860	9,912	2,275	2,83	11,03
45	37,5	38	22,5	105	14X20X17	98,2	150,1	4,533	16,161	4,533	16,161	2,935	3,70	11,03
53	43,5	44	30	120	16X23X20	118,1	161,5	4,654	16,016	4,654	16,016	3,779	4,36	15,26
53	43,5	44	30	120	16X23X20	142,0	210,1	7,468	26,493	7,468	26,493	4,916	5,76	15,26

1N=0,102kgf

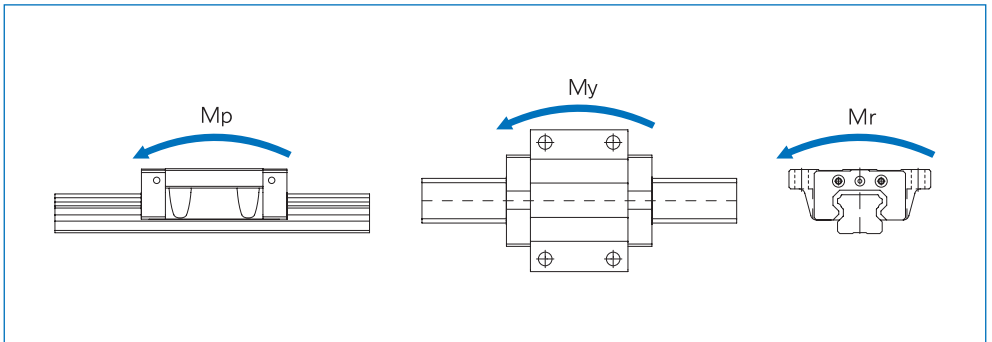

H-R Series, H-RL Series

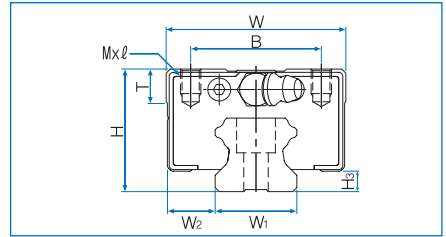
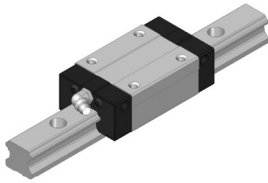

Model No.	External dimensions			Dimensions of block								Grease nipple	H ₃
	Height H	Width W	Length L	B	C	M x l	L ₁	T	N	E			
H 15R	28	34	57	26	26	M4 x 5	40,8	6	10	6	A-M4	4,7	
H 15RL	28	34	65,3	26	26	M4 x 5	49,1	6	10	6	A-M4	4,7	
H 20R	30	44	72,7	32	36	M5 x 6	53,1	8	7,5	12	B-M6F	6	
H 20RL	30	44	88,6	32	50	M5 x 6	69	8	7,5	12	B-M6F	6	
H 25R	40	48	83	35	35	M6 x 8	58,3	8	13	12	B-M6F	7	
H 25RL	40	48	102,9	35	50	M6 x 8	78,2	8	13	12	B-M6F	7	
H 30R	45	60	97,8	40	40	M8 x 10	70,8	8	10,3	12	B-M6F	7,5	
H 30RL	45	60	120	40	60	M8 x 10	93	8	10,3	12	B-M6F	7,5	
H 35R	55	70	110	50	50	M8 x 12	80,8	10	15	12	B-M6F	9	
H 35RL	55	70	135,4	50	72	M8 x 12	106,2	10	15	12	B-M6F	9	
H 45R	70	86	139	60	60	M10 x 17	101,9	15	20	16	B-PT1/8	10	
H 45RL	70	86	170,8	60	80	M10 x 17	133,7	15	20	16	B-PT1/8	10	
H 55R	80	100	163	75	75	M12 x 18	117,5	18	21	16	B-PT1/8	13	
H 55RL	80	100	201,1	75	95	M12 x 18	155,6	18	21	16	B-PT1/8	13	

Composition of Model No.

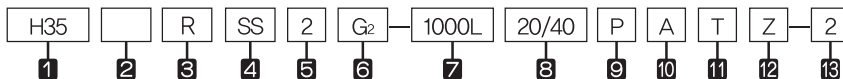

- 1 Model No. of Linear Motion Guide
 - 2 Type of block : **No symbol**–Full-ball type / **S**–Spacer retainer type
 - 3 Form of block : **R**–Rectangular standard type / **RL**–Rectangular long type / **F**–Flange standard type / **FL**–Flange long type
 - 4 Type of seal : **UU**–End seal / **SS**–End seal + Inside seal / **ZZ**–End seal + Inside seal + metal scraper (*1)
 - 5 Number of blocks combined in 1 rail
 - 6 Symbol of clearance : **No symbol**–Normal preload / **G₁**–Light preload / **G₂**–Heavy preload / **G_s**–Special preload (*2)
 - 7 Length of rail
 - 8 Size of G value : standard G value has no symbol.
 - 9 Symbol of precision : **No symbol**–Moderate precision / **H**–High precision / **P**–Precision / **SP**–Super Precision / **UP**–Ultra Precision (*3)
 - 10 **No symbol**–Rail counter bore type (A topside assembly) / **A**– Rail tap hole type (an underside assembly) (*4)
 - 11 Connection symbol
 - 12 Special symbol
 - 13 Number of axis used on the same surface
- (*1) See P77 Symbol List of Optional Parts (*2) See P17 Radial Clearance
 (*3) See P24 Selection of Precision Class (*4) See P47 Standard tap hole type of a rail

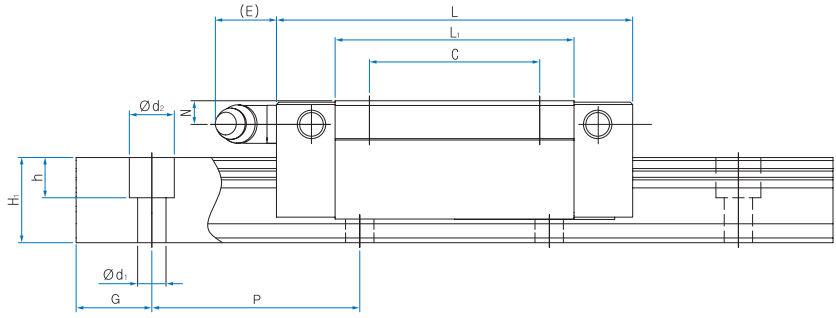

Unit : mm

Dimensions of Rail						Basic load rating		Static allowance moment kN·m					Mass	
Width W ₁ ±0.05	W ₂	Heigh H ₁	Value G	Pitch P	d ₁ x d ₂ x h	C kN	C ₀ kN	M _p		M _y		M _r	Block kg	Rail kg/m
								1	2(contact)	1	2(contact)	1		
15	9.5	13	20	60	4.5x7.5x5.3	9.9	16.2	0.115	0.552	0.115	0.552	0.129	0.18	1.3
15	9.5	13	20	60	4.5x7.5x5.3	11.2	19.3	0.165	0.769	0.165	0.769	0.154	0.23	1.3
20	12	16.5	20	60	6x9.5x8.5	14.9	23.9	0.221	1.049	0.221	1.049	0.251	0.31	2.2
20	12	16.5	20	60	6x9.5x8.5	17.8	30.7	0.370	1.692	0.370	1.692	0.322	0.41	2.2
23	12.5	20	20	60	7x11x9	22.1	33.1	0.337	1.636	0.337	1.636	0.398	0.53	3.0
23	12.5	20	20	60	7x11x9	26.8	43.6	0.596	2.760	0.596	2.760	0.525	0.71	3.0
28	16	26	20	80	9x14x12	38.4	57.1	0.711	3.384	0.711	3.384	0.828	0.9	4.85
28	16	26	20	80	9x14x12	45.9	73.6	1.203	5.506	1.203	5.506	1.067	1.1	4.85
34	18	29	20	80	9x14x12	51.1	74.6	1.062	5.012	1.062	5.012	1.298	1.5	6.58
34	18	29	20	80	9x14x12	61.0	96.2	1.797	8.172	1.797	8.172	1.674	2.01	6.58
45	20.5	38	22.5	105	14x20x17	82.1	116.4	2.860	9.912	2.860	9.912	2.275	2.89	11.03
45	20.5	38	22.5	105	14x20x17	98.2	150.1	4.533	16.161	4.533	16.161	2.935	3.74	11.03
53	23.5	44	30	120	16x23x20	118.1	161.5	4.654	16.016	4.654	16.016	3.779	4.28	15.26
53	23.5	44	30	120	16x23x20	142.0	210.1	7.468	26.493	7.468	26.493	4.916	5.59	15.26

1N=0.102kgf

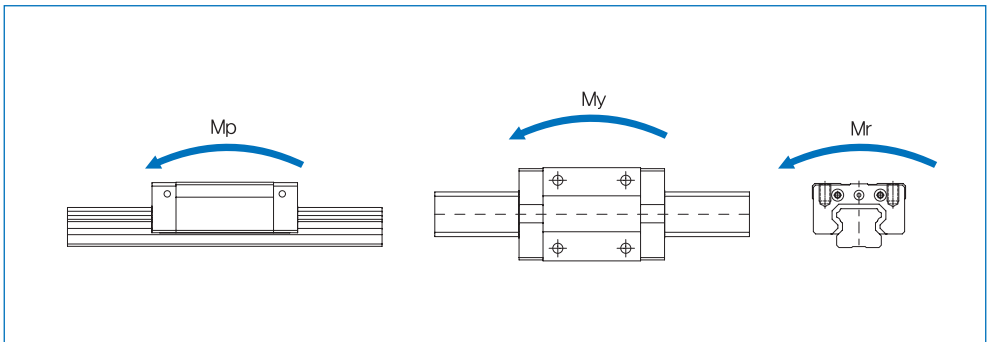

3. Slim Linear Motion Guide S Series

1) Structure of S Series

Linear Motion Guide S Series has a four-row circular arc-groove structure and is a 4-direction equal load type. It also has an auto-adjusting face-to-face D/F structure. It uses balls as a rolling element and is a slim-type guide with a low sectional height as well as high rigidity and less noise.

2) Features of S Series

- a. High quality and very effective in realizing high precision and elimination of labor
- b. High rigidity and high precision which can realize the stable travel for a long time
- c. Great wear resistance and friction resistance which ensures a long life
- d. Great auto-adjusting and error-absorbing abilities with the face-to-face duplex structure same to D/F combination of ball bearing
- e. Various specifications for easy design
- f. Easy to use due to great compatibility between a rail and a block
- g. 4-direction equal load and high-rigidity structure
- h. Slim shape suitable for horizontal motion to ensure stable running

Linear Motion Guide S Series

Ball Linear Motion Guide

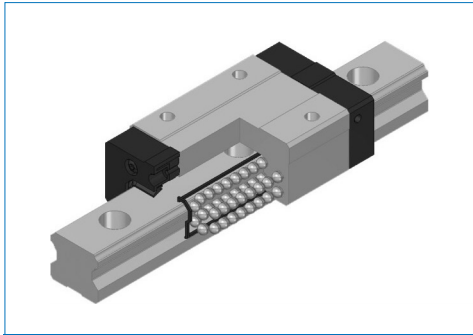

S Series (Full-ball Type)

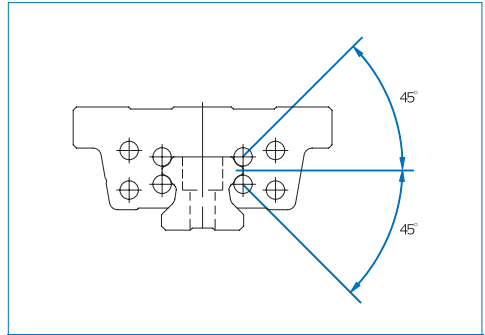

Cross Section

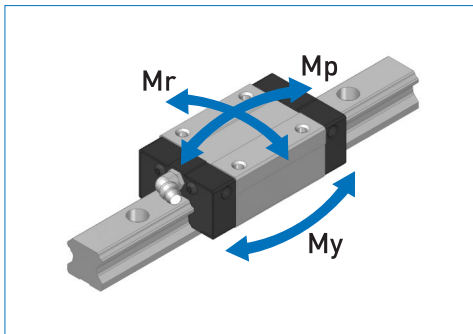

Moment Rigidity

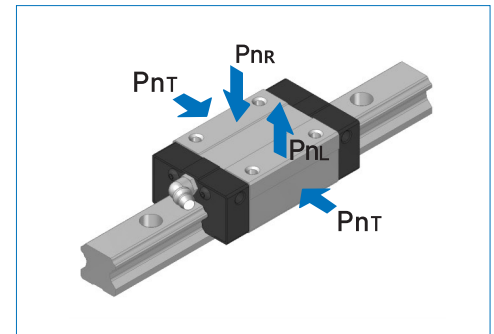

Radial Rigidity

Types and Features

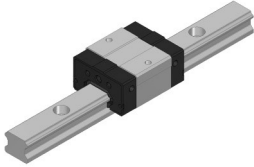
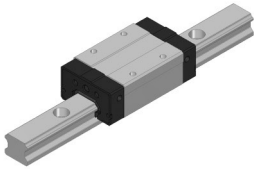
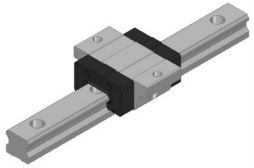
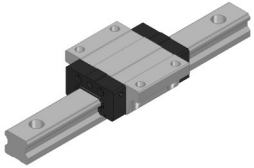
Category	Type	Shape & Features	
Compact type	S-C		<ul style="list-style-type: none"> - With the tapped flange of a block, a slim compact that the width and length of LM guide block is minimized - A 4-direction equal load type with 45° contact angle
	S-R		<ul style="list-style-type: none"> - Having the cross section identical to that of S-C Series, a slim compact type that the width and length of LM guide block is minimized - A 4-direction equal load type with 45° contact angle
Flange type	S-CF		<ul style="list-style-type: none"> - With the tapped flange of a block, a slim compact type that the width and length of LM guide block is minimized - A 4-direction equal load type with 45° contact angle
	S-F		<ul style="list-style-type: none"> - Having the cross section identical to that of S-CF Series, a slim compact type that the width and length of LM guide block is minimized - A 4-direction equal load type with 45° contact angle

Cartesian coordinated robot, linear actuator, automation system, semiconductor/display manufacturing system, LED inspection equipment, dispenser equipment, medical Equipment, high-speed transport system, woodworking machine, take-out robots, small machine tool, laser processor, precision measurement equipment

Standard tap hole type of a rail

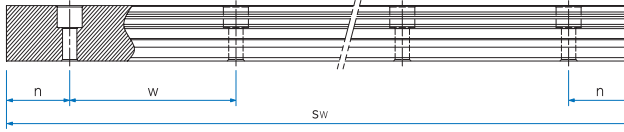

Unit : mm

Model No.	S15	S20	S25
Standard length	160	160	220
	220	220	280
	280	280	340
	⋮	340	400
	1360	⋮	460
	1480	1960	⋮
	1600	2080	2200
		2200	2320
			2440
Standard pitch P	60	60	60
G	20	20	20
Max. length	4000		

Standard tap hole type of a rail

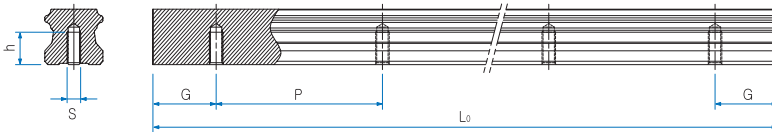

Unit : mm

Model No.	S	h(mm)
H15	M5	8
H20	M6	10
H25	M6	12

S-C Series, S-R Series

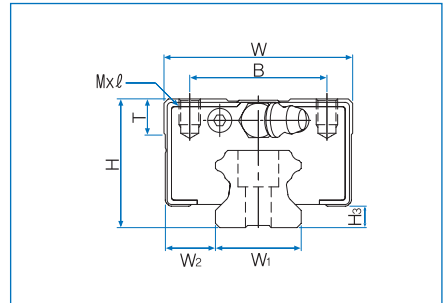
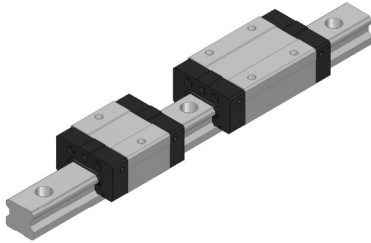

Model No.	External dimensions			Dimensions of block								Grease nipple	H ₃
	Height H	Width W	Length L	B	C	M x l	L ₁	T	N	E			
S 15C	24	34	40,2	26	–	M4 x 6	24	6	6	6	A-M4	4,5	
S 15R			56,9		26		40,7						
S 20C	28	42	47,2	32	–	M5 x 7	27,6	7,5	5,5	12	B-M6F	6	
S 20R			66,3		32		46,7						
S 25C	33	48	59,1	35	–	M6 x 9	34,4	8	6	12	B-M6F	7	
S 25R			83		35		58,2						

Composition of Model No.

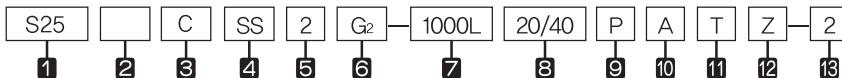

- 1 Model No. of Linear Motion Guide
- 2 Type of block : No symbol–Full-ball type / S–Spacer retainer type
- 3 Form of block : C–Rectangular standard type / R–Rectangular long type / CF–Flange standard type / F–Flange long type
- 4 Type of seal : UU–End seal / SS–End seal + Inside seal / ZZ–End seal + Inside seal + metal scraper (*1)
- 5 Number of blocks combined in 1 rail
- 6 Symbol of clearance : No symbol–Normal preload / G₁–Light preload / G₂–Heavy preload / G_s–Special preload (*2)
- 7 Length of rail
- 8 Size of G value : standard G value has no symbol.
- 9 Symbol of precision : No symbol–Moderate precision / H–High precision / P–Precision / SP–Super Precision / UP–Ultra Precision (*3)
- 10 No symbol–Rail counter bore type (A topside assembly) / A– Rail tap hole type (an underside assembly)(*4)
- 11 Connection symbol
- 12 Special symbol
- 13 Number of axis used on the same surface

(*1) See P77 Symbol List of Optional Parts (*2) See P17 Radial Clearance

(*3) See P24 Selection of Precision Class (*4) See P55 The reference for standard tap hole type of a rail

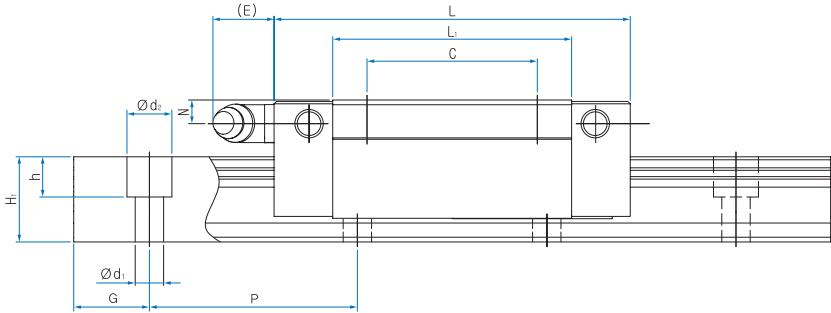

Unit : mm

Dimensions of Rail						Basic load rating		Static allowance moment kN·m					Mass	
Width W ₁ ±0.05	W ₂	Heigh H ₁	Value G	Pitch P	d ₁ x d ₂ x h	C kN	C ₀ kN	M _p		M _y		M _r	Block kg	Rail kg/m
								1	2(contact)	1	2(contact)	1		
15	9,5	13	20	60	4,5x7,5x5,3	7,0	10,0	0,042	0,224	0,042	0,224	0,079	0,096	1,3
						9,9	16,2	0,115	0,552	0,115	0,552	0,129	0,156	
20	11	16,5	20	60	6x9,5x8,5	9,8	13,1	0,063	0,342	0,063	0,342	0,137	0,153	2,2
						13,7	21,2	0,173	0,838	0,173	0,838	0,223	0,246	
23	12,5	20	20	60	7x11x9	15,7	20,4	0,123	0,670	0,123	0,670	0,246	0,254	3,0
						22,1	33,1	0,337	1,636	0,337	1,636	0,398	0,413	

1N=0,102kgf

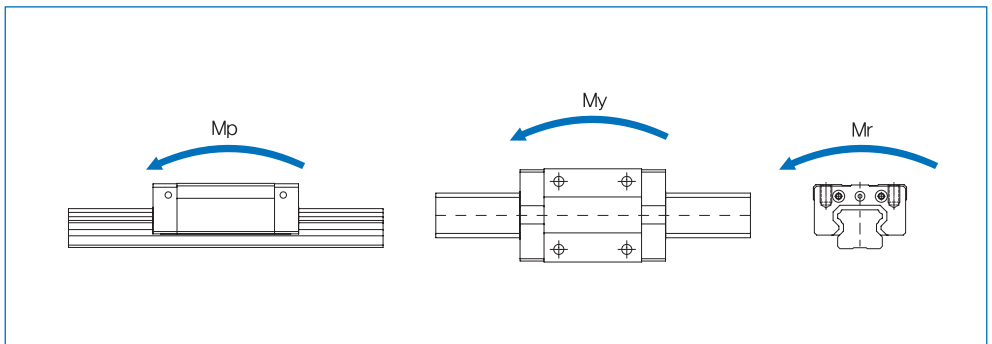

S-CF Series, S-F Series

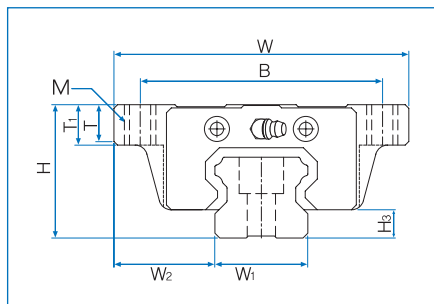
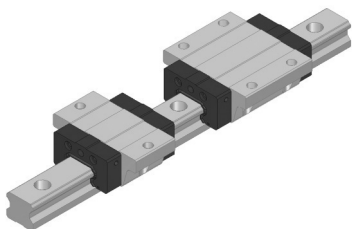

Model No.	External dimensions			Dimensions of block										H ₃
	Height H	Width W	Length L	B	C	M x ℓ	L ₁	T	T ₁	N	E	Grease nipple		
S 15CF	24	52	40,2	41	–	M5	24	6	7	6	6	A-M4	4,5	
S 15F			56,9		26		40,7							
S 20CF	28	59	47,2	49	–	M6	27,6	8	9	5,5	12	B-M6F	6	
S 20F			66,3		32		46,7							
S 25CF	33	73	59,1	60	–	M8	34,4	9	10	6	12	B-M6F	7	
S 25F			83		35		58,2							

Composition of Model No.

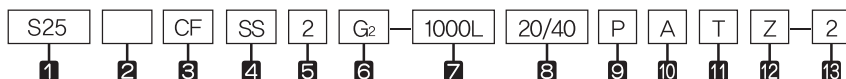

- 1 Model No. of Linear Motion Guide
- 2 Type of block : **No symbol**–Full-ball type / **S**–Spacer retainer type
- 3 Form of block : **C**–Rectangular standard type / **R**–Rectangular long type / **CF**–Flange standard type / **F**–Flange long type
- 4 Type of seal : **UU**–End seal / **SS**–End seal + Inside seal / **ZZ**–End seal + Inside seal + metal scraper (*1)
- 5 Number of blocks combined in 1 rail
- 6 Symbol of clearance : **No symbol**–Normal preload / **G₁**–Light preload / **G₂**–Heavy preload / **G_s**–Special preload (*2)
- 7 Length of rail
- 8 Size of G value : standard G value has no symbol.
- 9 Symbol of precision : **No symbol**–Moderate precision / **H**–High precision / **P**–Precision / **SP**–Super Precision / **UP**–Ultra Precision (*3)
- 10 **No symbol**–Rail counter bore type (A topside assembly) / **A**– Rail tap hole type (an underside assembly) (*4)
- 11 Connection symbol
- 12 Special symbol
- 13 Number of axis used on the same surface

(*1) See P77 Symbol List of Optional Parts (*2) See P17 Radial Clearance

(*3) See P24 Selection of Precision Class (*4) See P55 The reference for standard tap hole type of a rail

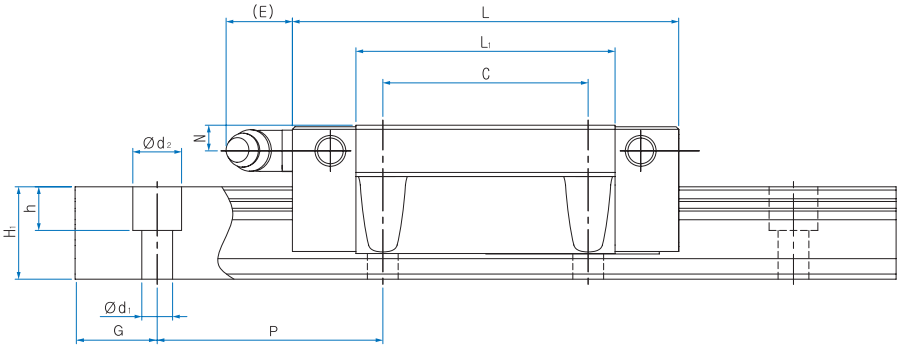

Unit : mm

Width W1 ±0.05	Dimensions of Rail					Basic load rating		Static allowance moment kN·m					Mass	
	W2	Heigh H1	Value G	Pitch P	d1 x d2 x h	C kN	Co kN	Mp		My		Mr	Block kg	Rail kg/m
								1	2(contact)	1	2(contact)	1		
15	18,5	13	20	60	4,5x7,5x5,3	7.0	10.0	0.042	0.224	0.042	0.224	0.079	0,125	1,3
						9.9	16.2	0.115	0.552	0.115	0.552	0.129	0,203	
20	19,5	16,5	20	60	6x9,5x8,5	9.8	13.1	0.063	0.342	0.063	0.342	0.137	0,187	2,2
						13.7	21.2	0.173	0.838	0.173	0.838	0.223	0,301	
23	25	20	20	60	7x11x9	15.7	20.4	0.123	0.670	0.123	0.670	0.246	0,320	3,0
						22.1	33.1	0.337	1.636	0.337	1.636	0.398	0,527	

1N=0,102kgf

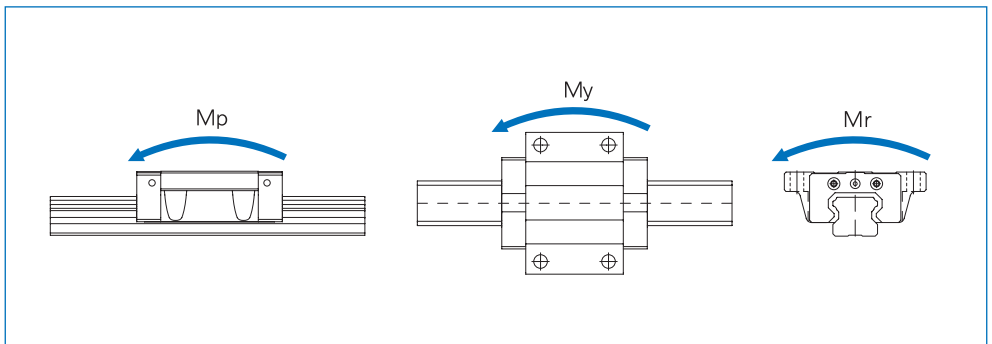

5. Miniature Linear Motion Guide M Series

1) Structure of M Series

WON Miniature Linear Motion Guide M Series has a shape of a gothic-arch groove in the raceway between a rail and a block and a 4-direction equal type structure with 2-row 4-point contact balls at 45 degree. Even though it is small in size, it provides stable travel and rigidity under the environment where variable load and combined load is applied.

2) Features of M Series

- a. A compact highly-rigid 4-direction equal load type
- b. Various specifications for easy design with space and load rating taken into account
- c. Balls are maintained during the assembly of a block and a rail since a wire to retain balls is built in the block.
- d. It's material is stainless steel which does not rust easily, so it is very suitable for the environment where rust and particle generation should be prevented - clean room, for instance.

6. Wide Miniature Linear Motion Guide MB Series

1) Structure of MB Series

WON Miniature Linear Motion Guide MB Series has a 4-direction equal load type which is identical to M Series, and the basic load rating and moment load are significantly improved compared to the general M Series by broadening the width between a rail and a block.

2) Features of MB Series

- a. As the width between a rail and a block is broadened and the number of balls increased, load rating and moment load are improved.
- b. Suitable for use in a one-axis type since it is wider than the general miniature Linear Motion guide and rigidity increased.
- e. A compact highly-rigid 4-direction equal load type
- f. Various specifications for easy design with space and load rating taken into account
- g. Balls are maintained during the assembly of a block and a rail since a wire to retain balls is built in the block.
- h. Its material is stainless steel which does not rust easily so it is very suitable for the environment where rust and particle generation should be prevented for clean room, for instance.
For MB12 and MB15 Model Numbers, Bearing Steel material (MBT12, MBT15) is ready to produce.

Miniature Linear Motion Guide

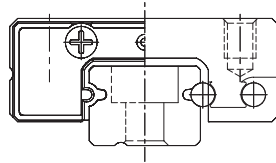
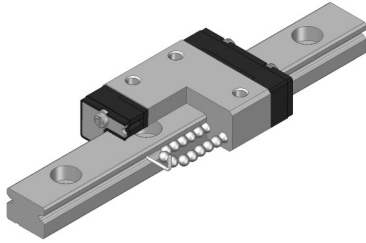

Standard M Series

Standard

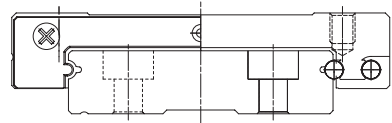
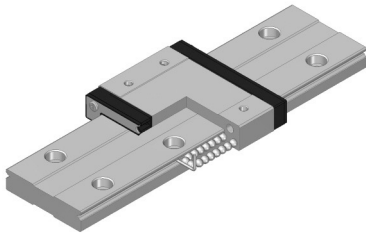

Wide body MB Series

Wide body

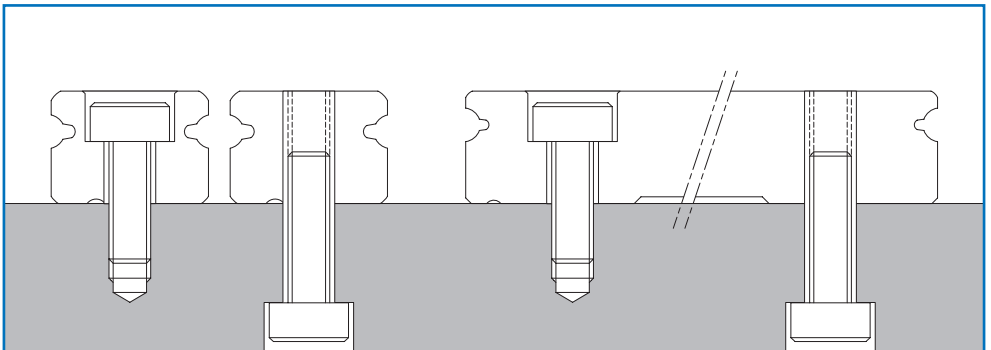

Bolt fastening

Types and Features

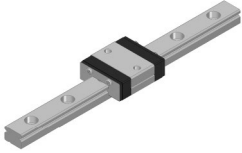
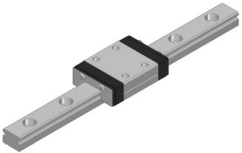
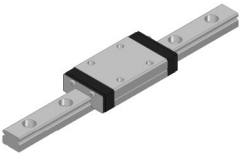
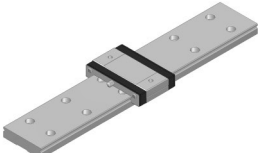
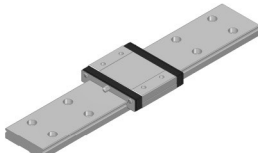
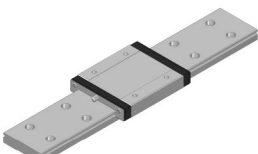
Category	Type	Shape & Features		
Compact type	M-C		Standard Miniature Linear Motion Guide	Semiconductor test equipment, semiconductor assembly equipment, display test equipment, HEAD-axis LED inspection equipment, pneumatic machinery, table cylinder, automation machinery, medical equipment, smart actuators, Cartesian coordinated robot, UVW stage
	M-N			
	M-L			
Wide board	MB-C MBT-C		High rigidity is achieved as the block is wider and longer than M Series to increase load rating and allowable moment. For MB12 and MB15 Model Numbers, Bearing Steel material(MBT 12, MBT15) is ready to produce.	
	MB-N MBT-N			
	MB-L MBT-L			

Standard and maximum length of a rail

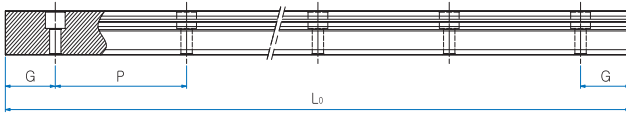

Unit : mm

Model No.	M5	M7	M9	M12	M15	M20
Standard length	40	40	55	70	70	220
	55	55	75	95	110	280
	70	70	95	120	150	340
	∴	∴	115	145	190	460
	100	100	∴	170	230	∴
	130	130	275	∴	∴	1120
	160	160	375	570	670	1240
			495	695	870	1360
Standard maximum length of a rail	1000	1000	995	1995	1990	1960
				820	1070	
Standard pitch P	15	15	20	25	40	60
G	5	5	7.5	10	15	20
Max. length	1000			2000		

MB5	MB7	MB9	MB12	MB15
50	50	50	70	110
70	80	80	110	150
90	110	110	150	190
∴	∴	140	190	230
130	260	∴	230	270
150	290	500	∴	∴
170	350	710	590	750
		860	750	790
			910	910
990	980	980	1990	1990
20	30	30	40	40
5	10	10	15	16
1000			2000	

Standard tap hole type of a rail

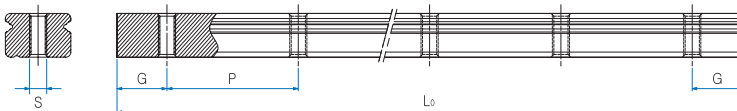

Model No.	S (Thru)
M5	M3
M7	M3
M9	M4
M12	M4
M15	M4
M20	M6

Model No.	S (Thru)
MB5	M3
MB7	M4
MB9	M4
MB12	M5
MB15	M5

M Series

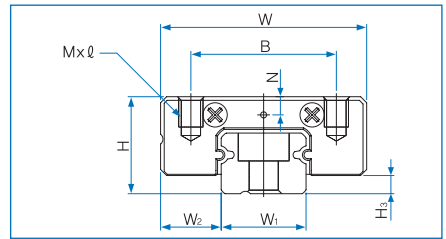
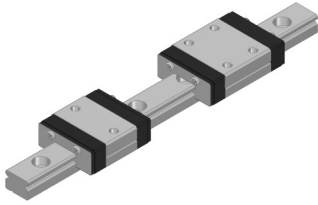

Model No.	External dimensions			Dimensions of block							H ₃
	Height H	Width W	Length L	B	C	M x l	L ₁	N	E	Grease nipple	
M 5C	6	12	17	8	—	M2 x 1,5	9,4	1,2	—	—	1
M 5N			20		—		12,4		—	—	
M 7C	8	17	19,8	12	—	M2 x 2,5	9,6	1,5	—	—	1,5
M 7N			24,3		8		14,1		—	—	
M 7L			31,8		13 (12)		21,6		—	—	
M 9C	10	20	22,4	15	—	M3 x 3	11,8	2,2	—	—	2
M 9N			31,3		10		20,7		—	—	
M 9L			41,4		16 (15)		30,8		—	—	
M 12C	13	27	26,4	20	—	M3 x 3,5	12,8	2,7	—	—	3
M 12N			34,9		15		21,3		—	—	
M 12L			45,4		20		31,8		—	—	
M 15C	16	32	34,4	25	—	M3 x 4	17,7	3,1	4	A-M3	4
M 15N			44,4		20		27,7		4		
M 15L			59,4		25		42,7		4		
M 20C	20	40	39,8	30	—	M4 x 6	22,2	4,2	4	A-M3	5
M 20N			51,8		25		34,2		4		
M 20L			69,8		30		52,2		4		

Composition of Model No.

Among C Value measurement of M7L and M9L Model Numbers, it is possible to order the measurement in the parentheses.

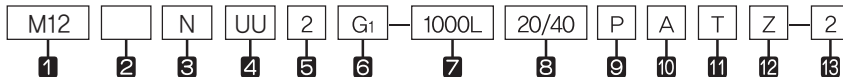

- 1 Model No. of Linear Motion Guide
- 2 Type of block : No symbol—Full-ball type
- 3 Form of block : C—Rectangular short type / N—Rectangular standard type / L—Flange long type
- 4 Type of seal : UU—End seal (*1)
- 5 Number of blocks combined in 1 rail
- 6 Symbol of clearance : No symbol—Normal preload / G₁—Light preload (*2)
- 7 Length of rail
- 8 Size of G value : standard G value has no symbol.
- 9 Symbol of precision : No symbol—Moderate precision / H—High precision / P—Precision (*3)
- 10 No symbol—Rail counter bore type (A topside assembly) / A— Rail tap hole type (an underside assembly) (*4)
- 11 Connection symbol
- 12 Special symbol
- 13 Number of axis used on the same surface

(*1) See P77 Symbol List of Optional Parts (*2) See P17 Radial Clearance

(*3) See P24 Selection of Precision Class (*4) See P63 The reference for standard tap hole type of a rail

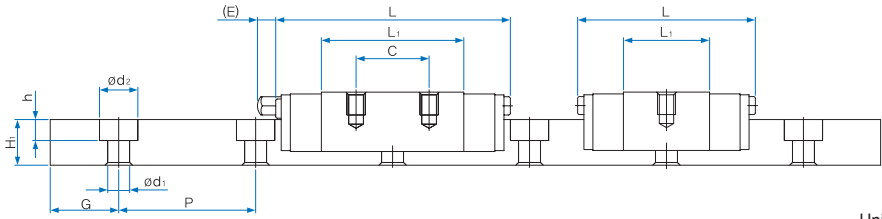

Unit : mm

Dimensions of Rail						Basic load rating		Static allowance moment N·m					Mass	
Width W ₁	W ₂	Heigh H ₁	Value G	Pitch P	d ₁ x d ₂ x h	C N	C ₀ N	M _p		M _y		M _r	Block g	Rail g/m
								1	2(contact)	1	2(contact)			
5 ⁰ _{-0.02}	3,5	3,7	5	15	2,4x3,6x0,8	516	757	1.3	7.1	1.3	7.1	2.01	3.1	139
						631	1,009	2.2	11.6	2.2	11.6	2.67	4.0	
7 ⁰ _{-0.02}	5	5	5	15	2,4x4,2x2,3	901	1,136	1.9	11.8	1.9	11.8	4.14	6.4	253
						1,197	1,703	4.2	23.1	4.2	23.1	6.22	9.0	
						1,631	2,650	10.1	50.0	10.1	50.0	9.67	12.6	
9 ⁰ _{-0.02}	5.5	6	7.5	20	3,5x6x3,5	1,180	1,485	3.1	17.9	3.1	17.9	6.90	9.9	391
						1,721	2,545	9.3	46.6	9.3	46.6	11.84	17.1	
						2,375	4,030	21.9	102.8	21.9	102.8	18.74	25.2	
12 ⁰ _{-0.025}	7.5	8	10	25	3,5x6,5x4,5	2,175	2,385	5.4	32.9	5.4	32.9	14.79	19.8	679
						3,023	3,816	14.4	75.8	14.4	75.8	23.66	31.5	
						4,246	6,200	34.8	169.1	34.8	169.1	38.44	45.9	
15 ⁰ _{-0.025}	8.5	10	15	40	3,5x6,5x4,5	3,418	3,895	12.2	71.6	12.2	71.6	29.99	37.8	1071
						4,540	5,842	28.6	148.7	28.6	148.7	44.99	57.6	
						6,492	9,737	73.5	351.2	73.5	351.2	74.98	85.5	
20 ⁰ _{-0.03}	10	11	20	60	6x9,5x5,5	4,512	5,299	20.7	115.9	20.7	115.9	54.05	80.1	1572
						6,191	8,328	50.2	252.7	50.2	252.7	84.94	119.7	
						8,396	12,870	118.6	554.4	118.6	554.4	131.27	176.4	

1N=0,102kgf

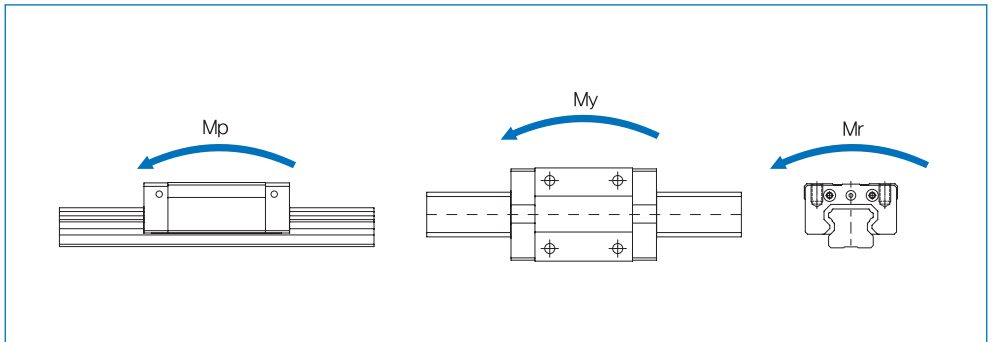

MB Series

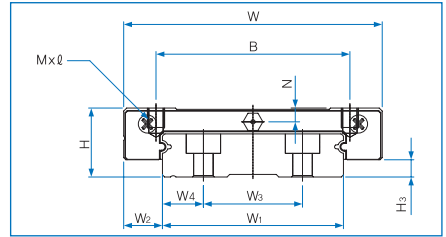
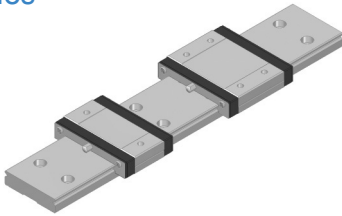

Model No.	External dimensions			Dimensions of block							Grease nipple	H ₃
	Height H	Width W	Length L	B	C	M x l	L ₁	N	E			
MB 5C	6,5	17	21	13	–	M2,5 x 1,5	13,4	1,4	–	–	1,3	
MB 5N			25		–		17,4		–	–		
MB 7C	9	25	24	19	–	M3 x 3	12,6	1,7	–	–	2	
MB 7N			33		10		21,6		–	–		
MB 7L			43,5		19		32,1		–	–		
MB 9C	12	30	28,1	21	–	M3 x 3	16,5	3,2	–	–	3	
MB 9N			40,2		12		28,6		–	–		
MB 9L			52		24		40,4		–	–		
MB 12C	14	40	31,1	28	–	M3 x 3,5	17,5	3	–	–	4	
MB 12N			44,5		15		30,9		–	–		
MB 12L			59,7		28		46,1		–	–		
MB 15C	16	60	42,8	45	–	M4 x 4,5	25,2	3,5	4	A=M3	4	
MB 15N			56,6		20		39		4			
MB 15L			75,8		35		58,2		4			

Composition of Model No.

For MB12 and MB15 Model Numbers,
Bearing Steel material (MBT12, MBT15) is ready to produce.

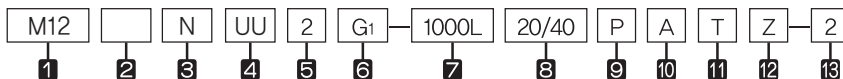

- 1 Model No. of Linear Motion Guide
- 2 Type of block : No symbol–Full-ball type
- 3 Form of block : C–Rectangular short type / N–Rectangular standard type / L–Flange long type
- 4 Type of seal : UU–End seal (*1)
- 5 Number of blocks combined in 1 rail
- 6 Symbol of clearance : No symbol–Normal preload / G₁–Light preload (*2)
- 7 Length of rail
- 8 Size of G value : standard G value has no symbol.
- 9 Symbol of precision : No symbol–Moderate precision / H–High precision / P–Precision (*3)
- 10 No symbol–Rail counter bore type (A topside assembly) / A–Rail tap hole type (an underside assembly) (*4)
- 11 Connection symbol
- 12 Special symbol
- 13 Number of axis used on the same surface

(*1) See P77 Symbol List of Optional Parts (*2) See P17 Radial Clearance

(*3) See P24 Selection of Precision Class (*4) See P63 The reference for standard tap hole type of a rail

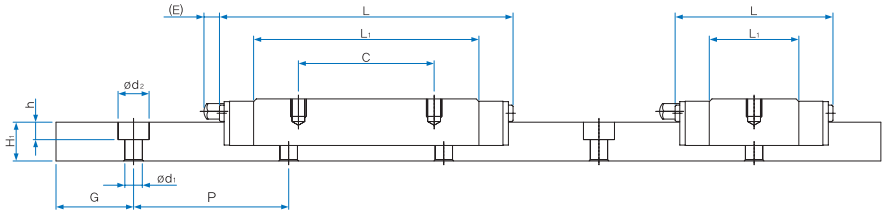

Unit : mm

Dimensions of Rail							Basic load rating		Static allowance moment N·m					Mass		
Width W_1	W_2	W_3	W_4	Heigh H_1	Value G	Pitch P	$d_1 \times d_2 \times h$	C N	C_0 N	M_p		M_y		M_r	Block g	Rail g/m
									1	2(contact)	1	2(contact)	1			
10 ⁰ _{-0.025}	3,5	-	-	4	5	20	2,9x4,8x1,6	668	1,094	2.6	13.3	2.6	13.3	5.63	5.3	299
								80.6	1,430	4.4	21.4	4.4	21.4	7.36	6.8	
14 ⁰ _{-0.05}	5,5	-	-	5,5	10	30	3,5x6x3,2	1,102	1,514	3.4	19.5	3.4	19.5	10.83	11.7	560
								1,631	2,650	10.1	51.1	10.1	51.1	18.95	18.9	
								2,166	3,975	22.5	106.1	22.5	106.1	28.42	27.9	
18 ⁰ _{-0.05}	6	-	-	7	10	30	3,5x6x4,5	1,515	2,121	6.2	33.4	6.2	33.4	19.41	23.4	912
								2,197	3,606	18.2	87.6	18.2	87.6	33.00	39.6	
								2,878	5,303	37.8	172.9	37.8	172.9	48.52	54.9	
24 ⁰ _{-0.05}	8	-	-	8,5	15	40	4,5x8x4,5	2,753	3,339	10.3	57.3	10.3	57.3	40.73	40.5	1369
								4,015	5,723	31.2	152.2	31.2	152.2	69.83	68.4	
								5,539	9,062	73.8	338.7	73.8	338.7	110.56	99.9	
42 ⁰ _{-0.05}	9	23	9,5	9,5	15	40	4,5x8x4,5	4,954	6,056	26.9	145.3	26.9	145.3	128.40	85.5	2886
								6,579	9,085	62.5	306.5	62.5	306.5	192.60	126.0	
								9,076	14,384	147.8	680.6	147.8	680.6	304.94	183.6	

1N=0,102kgf

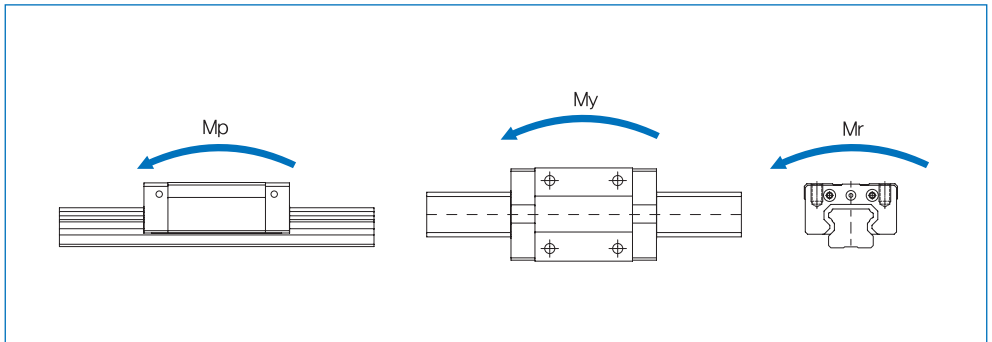

7. Roller Linear Motion Guide R Series

1) Structure of R Series

WON Linear Motion Guide R Series uses rollers as a rolling element between the raceway surface of a rail and a block and its four-row cylindrical roller forms a contact angle of 45° which bears equal load for vertical tensile compression load and horizontal load.

A roller used as a rolling element has less elastic displacement than a ball so it has small displacement for external load. Also the contact area with the roller is wide so that it has advantages such as high rigidity, bearing against big load, long life, impact resistance and wear resistance as well as less friction resistance that supports smooth motion and quite running.

Moreover if the roller is preloaded, it can enhance the rigidity of Linear Motion guide.

2) Features of R Series

- a. High quality and very effective in realizing high precision and elimination of labor
- b. High rigidity and high precision which can realize the stable travel for a long time
- c. Great wear resistance and friction resistance which ensures a long life
- d. High rigidity and overload capacity compared to ball types of the same model no.
- e. Excellent vibration resistance since it has less displacement against impact load or variable load than ball types and vibration decay time is shorter compared to natural frequency.
- f. Bigger basic static load rating than ball-type Linear Motion guide with the same specifications allows the compact design using smaller model no. than ball types. If same model no. is used, it achieves longer life due to bigger load rating.
- g. Various specification for easy design

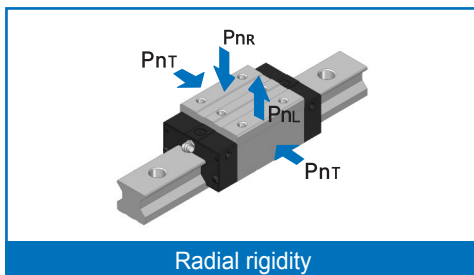
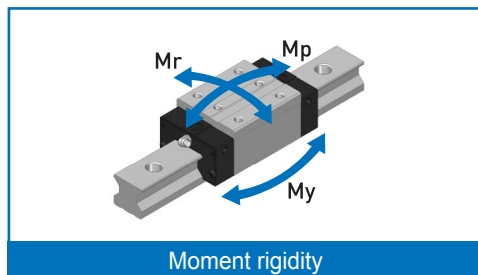

Rail bolt fastening type

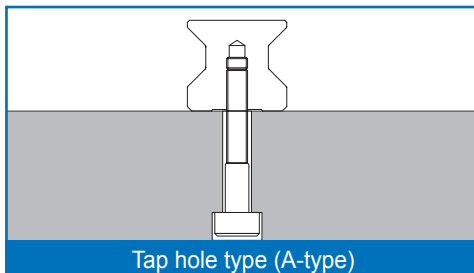
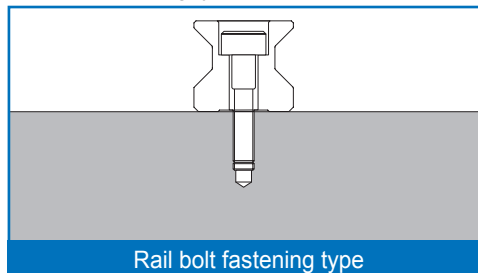

Linear Motion Roller Guide

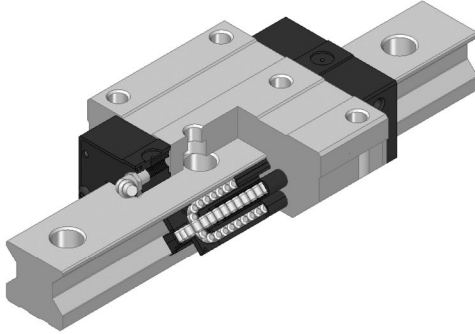

R Series

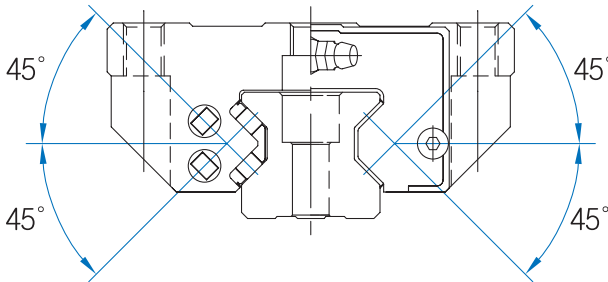

Cross Section

Types and Features

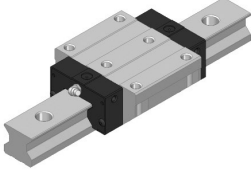
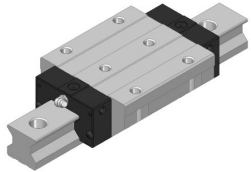
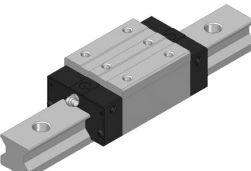
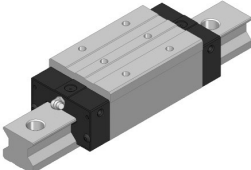
Category	Type	Shape & Features		
Flange type	R-F		<ul style="list-style-type: none"> - With the tapped flange of a lock, it can be assembled both from bottom to top and from top to bottom - A 4-direction equal load type with high rigidity and high load 	Machine tool, CNC machining center, CNC tapping center, NC milling machine, boring machine, multiple machining center, planer miller, large injection machine, heavy-duty cutting machine, wire-cut pentahedral processing center, display test equipment
	R-FL		<ul style="list-style-type: none"> - Having the roller contact structure and the cross section identical to those of S-F Series, it increased load rating by extending the whole length (L_1) of Linear Motion guide block - A 4-direction equal load type with high rigidity and high load 	
Compact type	R-R		<ul style="list-style-type: none"> - With the tapped top side of a block, a compact type that the width of Linear Motion guide block is minimized - A 4-direction equal load type with high rigidity and high load 	
	R-RL		<ul style="list-style-type: none"> - Having the cross section identical to that of H-R Series, it increased load rating by extending the whole length (L_1) of Linear Motion guide block - A 4-direction equal load type with high rigidity and high load 	

Standard and maximum length of a rail

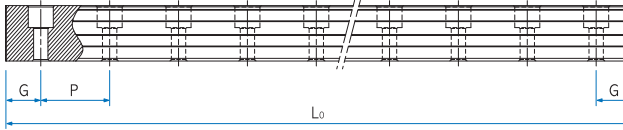

Unit : mm

Model No.	35	45	55
Standard length	280	570	780
	520	885	900
	920	1095	1140
	1240	1305	1380
	1400	1515	1620
	∴	∴	∴
	1960	2040	2100
	2360	2460	2580
	2840	2985	3060
			3090
Standard pitch P	40	52.5	60
G	20	22.5	30
Max. length	4000		

Standard tap hole type of a rail

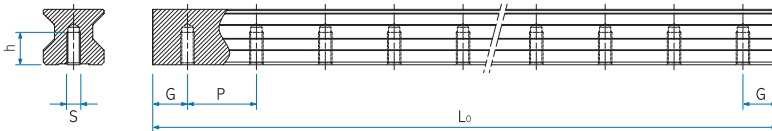

Model No.	S	h(mm)
R35	M8	17
R45	M12	24
R55	M14	24

R-F Series, R-FL Series

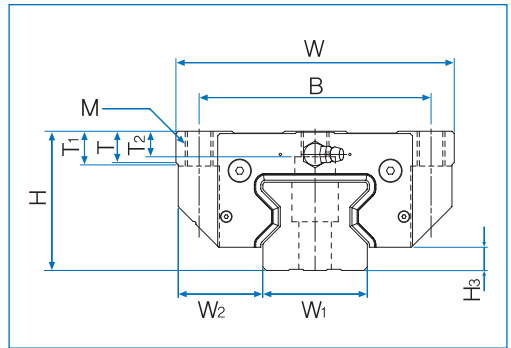
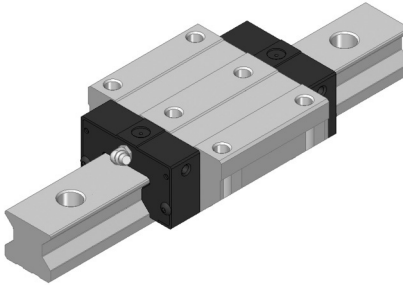

Model No.	External dimensions			Dimensions of block													Grease nipple	H ₃
	Height H	Width W	Length L	B	C	C ₂	M	S	L ₁	T	T ₁	T ₂	N	E				
R 35F	48	100	125,1	82	62	52	M10	8,5	82,5	12	13	8	8	12	B-M6F	7		
R 35FL	48	100	152,1	82	62	52	M10	8,5	109,5	12	13	8	8	12	B-M6F	7		
R 45F	60	120	154,4	100	80	60	M12	10,5	106,6	13,5	15	11	10	16	B-PT 1/8	10		
R 45FL	60	120	189,4	100	80	60	M12	10,5	141,6	13,5	15	11	10	16	B-PT 1/8	10		
R 55F	70	140	181,6	116	95	70	M14	12,5	127,8	17,5	18	13,5	11	16	B-PT 1/8	10		
R 55FL	70	140	229,6	116	95	70	M14	12,5	175,8	17,5	18	13,5	11	16	B-PT 1/8	10		

Composition of Model No.

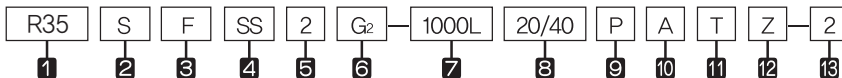

- 1 Model No. of Linear Motion Guide
- 2 Type of block : **No symbol**–Full-ball type / **S**–Spacer retainer type
- 3 Form of block : **R**–Rectangular standard type / **RL**–Rectangular long type / **F**–Flange standard type / **FL**–Flange long type
- 4 Type of seal : **UU**–End seal / **SS**–End seal + Inside seal / **ZZ**–End seal + Inside seal + metal scraper (*1)
- 5 Number of blocks combined in 1 rail
- 6 Symbol of clearance : **No symbol**–Normal preload / **G₁**–Light preload / **G₂**–Heavy preload / **G_s**–Special preload (*2)
- 7 Length of rail
- 8 Size of G value : standard G value has no symbol.
- 9 Symbol of precision : **No symbol**–Moderate precision / **H**–High precision / **P**–Precision / **SP**–Super Precision / **UP**–Ultra Precision (*3)
- 10 **No symbol**–Rail counter bore type (A topside assembly) / **A**– Rail tap hole type (an underside assembly) (*4)
- 11 Connection symbol
- 12 Special symbol
- 13 Number of axis used on the same surface

(*1) See P77 Symbol List of Optional Parts (*2) See P17 Radial Clearance

(*3) See P24 Selection of Precision Class (*4) See P71 The reference for standard tap hole type of a rail

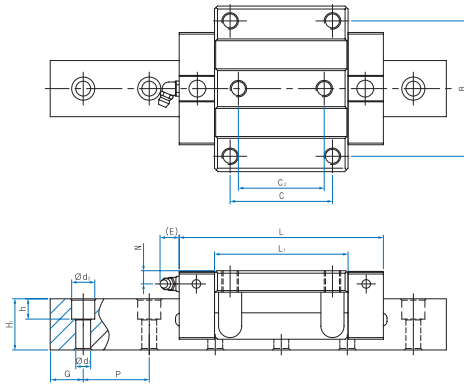

Unit : mm

Dimensions of Rail						Basic load rating		Static allowance moment kN·m					Mass	
Width W ₁ ±0.05	W ₂	Heigh H ₁	Value G	Pitch P	d ₁ x d ₂ x h	C kN	C ₀ kN	M _p		M _y		M _r	Block kg	Rail kg/m
								1	2(contact)	1	2(contact)			
34	33	31	20	40	9x14x12	50,7	121,5	1,772	8,919	1,772	8,919	2,606	1,703	6,27
34	33	31	20	40	9x14x12	63,5	162,0	3,136	14,985	3,136	14,985	3,475	2,263	6,27
45	37,5	38	22,5	52,5	14x20x17	82,3	210,0	3,957	19,380	3,957	19,380	5,652	3,19	10,193
45	37,5	38	22,5	52,5	14x20x17	102,9	280,0	7,009	32,771	7,009	32,771	7,536	4,266	10,193
53	43,5	43,5	30	60	16x23x20	114,8	283,5	6,406	31,061	6,406	31,061	9,364	5,393	13,37
53	43,5	43,5	30	60	16x23x20	147,5	391,6	12,168	56,12	12,168	56,121	12,931	7,5	13,37

1N=0,102kgf

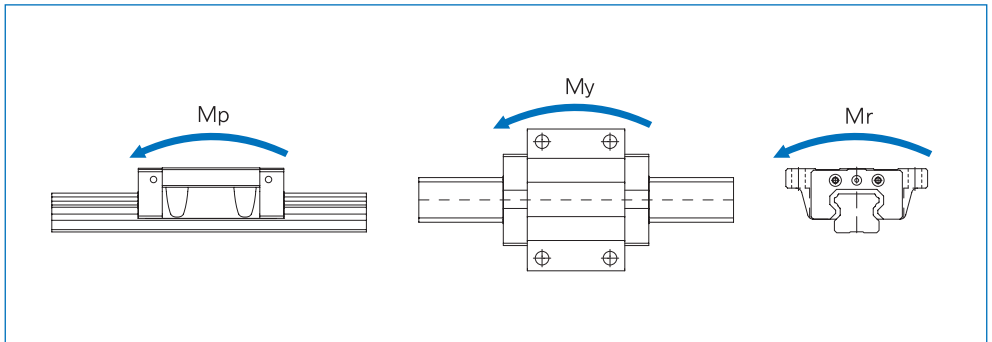

R-R Series, R-RL Series

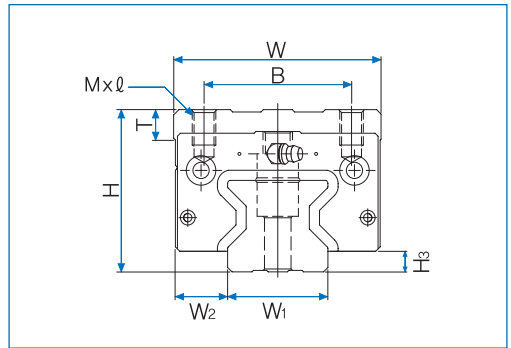
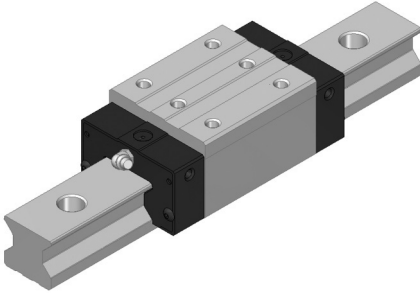

Model No.	External dimensions			Dimensions of block							Grease nipple	H ₃
	Height H	Width W	Length L	B	C	M x l	L ₁	T	N	E		
R 35R	55	70	125,1	50	50	M8 x 12	82,5	10,3	15	12	B-M6F	7
R 35RL	55	70	152,1	50	72	M8 x 12	109,5	10,3	15	12	B-M6F	7
R 45R	70	86	154,4	60	60	M10 x 20	106,6	24,5	20	16	B-PT 1/8	10
R 45RL	70	86	189,4	60	80	M10 x 20	141,6	24,5	20	16	B-PT 1/8	10
R 55R	80	100	181,6	75	75	M12 x 18	127,8	27,5	22	16	B-PT 1/8	10
R 55RL	80	100	229,6	75	95	M12 x 18	175,8	27,5	22	16	B-PT 1/8	10

Composition of Model No.

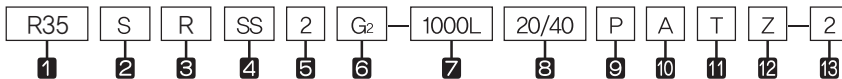

- 1 Model No. of Linear Motion Guide
- 2 Type of block : No symbol—Full-ball type / S—Spacer retainer type
- 3 Form of block : R—Rectangular standard type / RL—Rectangular long type / F—Flange standard type / FL—Flange long type
- 4 Type of seal : UU—End seal / SS—End seal + Inside seal / ZZ—End seal + Inside seal + metal scraper (*1)
- 5 Number of blocks combined in 1 rail
- 6 Symbol of clearance : No symbol—Normal preload / G₁—Light preload / G₂—Heavy preload / G_s—Special preload (*2)
- 7 Length of rail
- 8 Size of G value : standard G value has no symbol.
- 9 Symbol of precision : No symbol—Moderate precision / H—High precision / P—Precision / SP—Super Precision / UP—Ultra Precision (*3)
- 10 No symbol—Rail counter bore type (A topside assembly) / A—Rail tap hole type (an underside assembly) (*4)
- 11 Connection symbol
- 12 Special symbol
- 13 Number of axis used on the same surface

(*1) See P77 Symbol List of Optional Parts (*2) See P17 Radial Clearance

(*3) See P24 Selection of Precision Class (*4) See P71 The reference for standard tap hole type of a rail

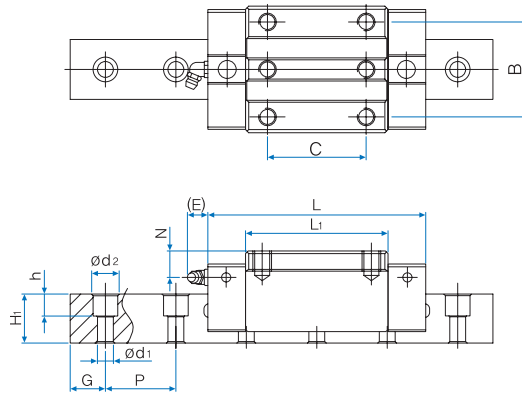

Unit : mm

Dimensions of Rail						Basic load rating		Static allowance moment kN·m					Mass	
Width W ₁ ±0.05	W ₂	Heigh H ₁	Value G	Pitch P	d ₁ x d ₂ x h	C kN	C ₀ kN	M _p		M _y		M _r	Block kg	Rail kg/m
								1	2(contact)	1	2(contact)	1		
34	18	31	20	40	9x14x12	50,7	121,5	1,772	8,919	1,772	8,919	2,606	1,179	6,27
34	18	31	20	40	9x14x12	63,5	162,0	3,136	14,985	3,136	14,985	3,475	2,263	6,27
45	20,5	38	22,5	52,5	14x20x17	82,3	210,0	3,957	19,380	3,957	19,380	5,652	3,103	10,193
45	20,5	38	22,5	52,5	14x20x17	102,9	280,0	7,009	32,771	7,009	32,771	7,536	4,08	10,193
53	23,5	43,5	30	60	16x23x20	114,8	283,5	6,406	31,061	6,406	31,061	9,364	4,723	13,37
53	23,5	43,5	30	60	16x23x20	147,5	391,6	12,168	56,121	12,168	56,121	12,931	6,466	13,37

1N=0,102kgf

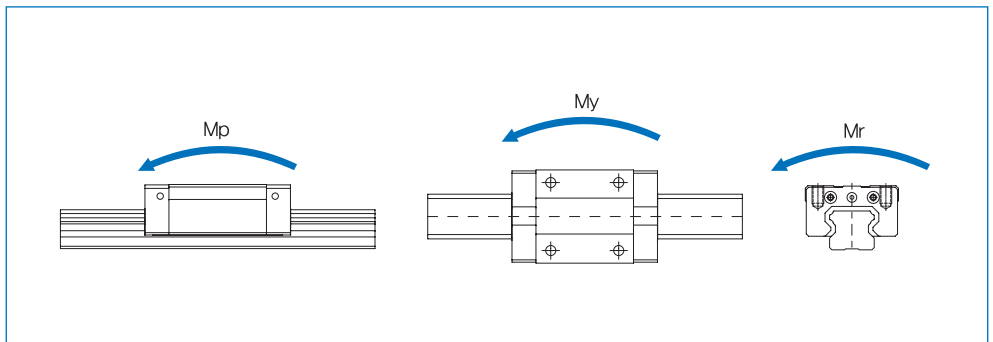

13 Options

1. Seal and Rail Cap

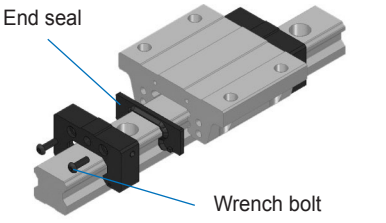
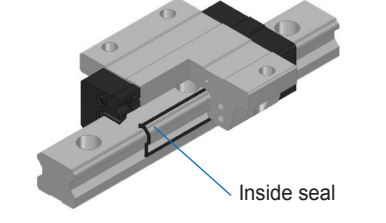
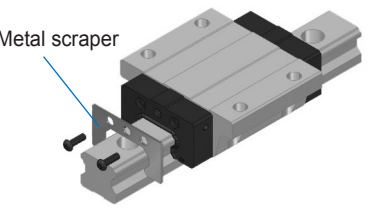
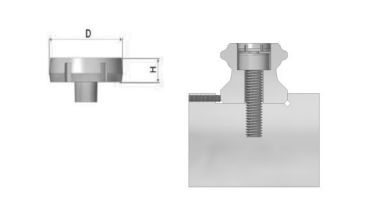
Item	Place to attach seal	Applications
End seal	 <p>End seal</p> <p>Wrench bolt</p>	<ul style="list-style-type: none"> - Where dust or particle is frequently generated
Inside seal	 <p>Inside seal</p>	<ul style="list-style-type: none"> - Where foreign substance can be easily accessed from the flank or bottom - Where Linear Motion guide is moving in a vertical, horizontal, and reverse direction - Where a lot of cutting chips or foreign substance present - Where there is a danger in the intrusion of cutting chips or foreign substances into the block
Metal scraper	 <p>Metal scraper</p>	<ul style="list-style-type: none"> - Where spatters may arise such as welding slag or metal powers
Rail cap	 <p>D</p> <p>H</p>	<ul style="list-style-type: none"> - If foreign substance enters into the bolt holes in a rail, it may intrude even into the block. A metal or plastic cap is used to prevent it. - plastic material railcap. - metal material railcap. - railcap for each part no in the catalog is available.

Symbol List of Optimal Parts

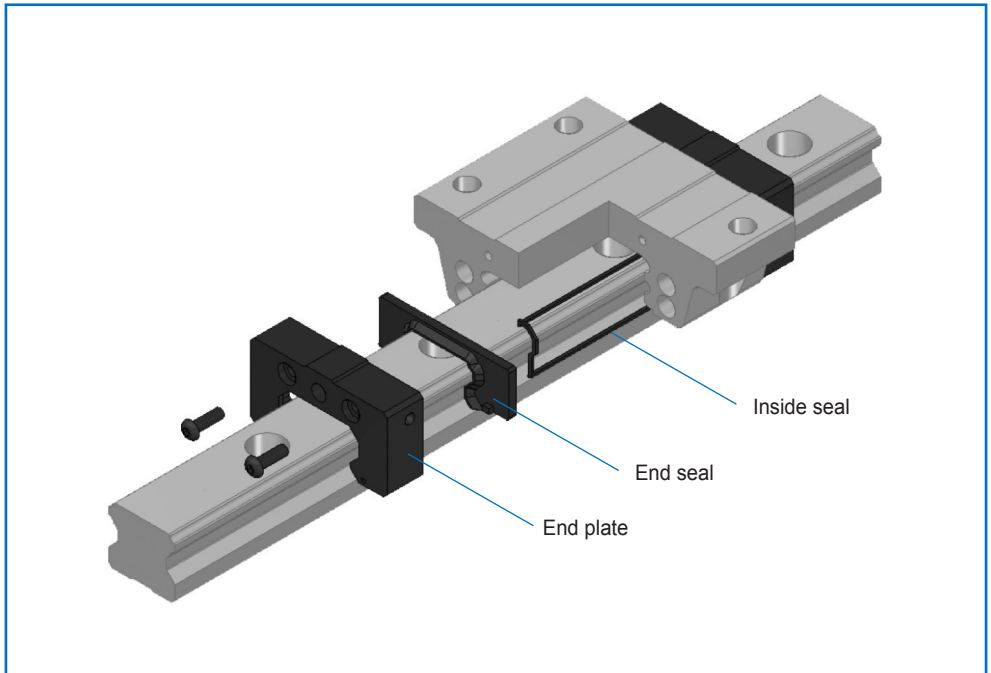

Symbol	Optional parts
UU	End seal
SS	End seal + Inside seal
ZZ	End seal + Inside seal + metal scraper

Option Mapping Table by Model No.

Symbol	Ball Linear Motion Guide	Miniature Linear Motion Guide	Roller Linear Motion Guide
	H Series / S Series	M / MB Series	R Series
UU	○	○	-
SS	○	-	-
ZZ	○	-	○

2. Oil Filler

Fuelling on the side and top is available in R Series. The standard specification does not include the oil filler that penetrates the block of Linear Motion guide to protect it from foreign substance. Therefore, if you have a request, please contact WON ST.

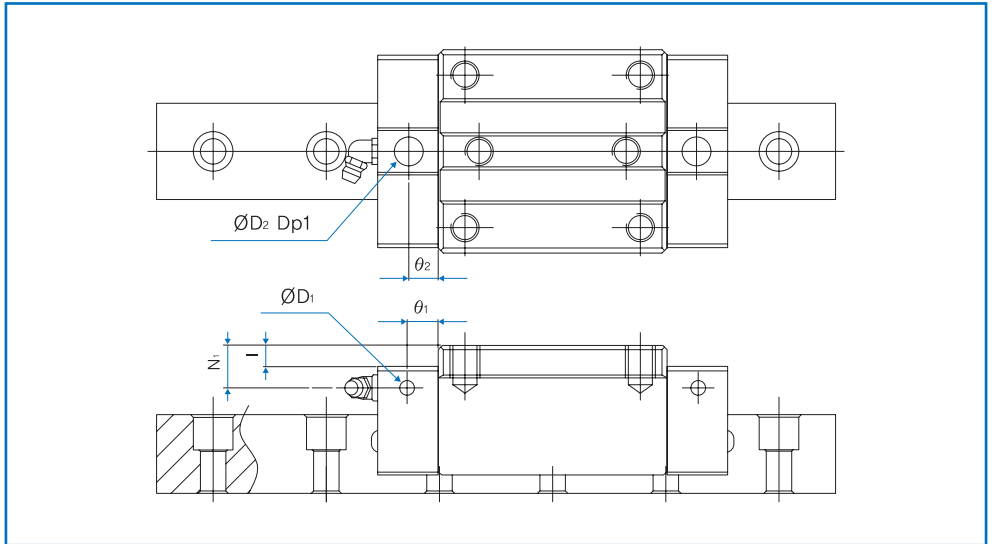

Unit : mm

Model No.	Hole for a side nipple			Top oil filler				
	θ_1	N_1	D_1	D_2	(O-ring)	l	θ_2	
R	35F(L)	10.4	8	5.2	10.7	S7	0.4	11
	35R(L)	10.4	15	5.2	10.7	S7	7.4	11
	45F(L)	10.4	10	5.2	10.7	S7	0.4	11
	45R(L)	10.4	20	5.2	10.7	S7	10.4	11
	55F(L)	12.5	11	5.2	10.7	S7	0.4	11
	55R(L)	12.5	21	5.2	10.7	S7	10.4	11

3. Grease Nipple

WON ST provides various kinds of grease nipple necessary for lubricating the system of Linear Motion guide.

Grease nipple				
Grease nipple model no.	A-M3	A-M4	B-M6F	B-PT1/8
Application model no.	M15, 20 MB 15	H 15 S 15	H 20, 25, 30, 35 S 20, 25 R 35	H 45, 55 R 45, 55

4. Connection of oil pipes

WOL Type

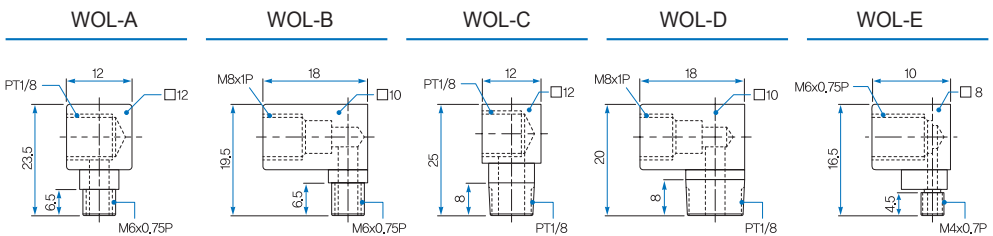

WOS Type

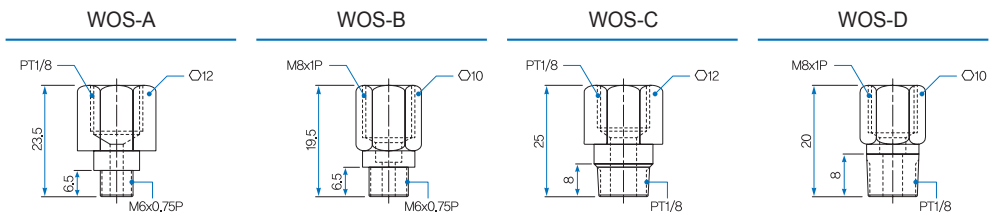

5. How to install Linear Motion guide using a support rail

Linear Motion guide block should be inserted into or removed from the rail using a support rail for safety.

If you install the block in the rail without using the support rail, a rolling element may deviate from the block and damage or destroy the parts inside.

If the block without a rolling element is installed, it may significantly shorten the block's life and lead to load reduction and early breakage.

If you use the support rail, do not lean it. Adhere it to the end of the rail and slowly apply force to assemble it.

If the block is contaminated by dust as the rolling element is deviated from it, please do not use the product and contact WON ST for advice.

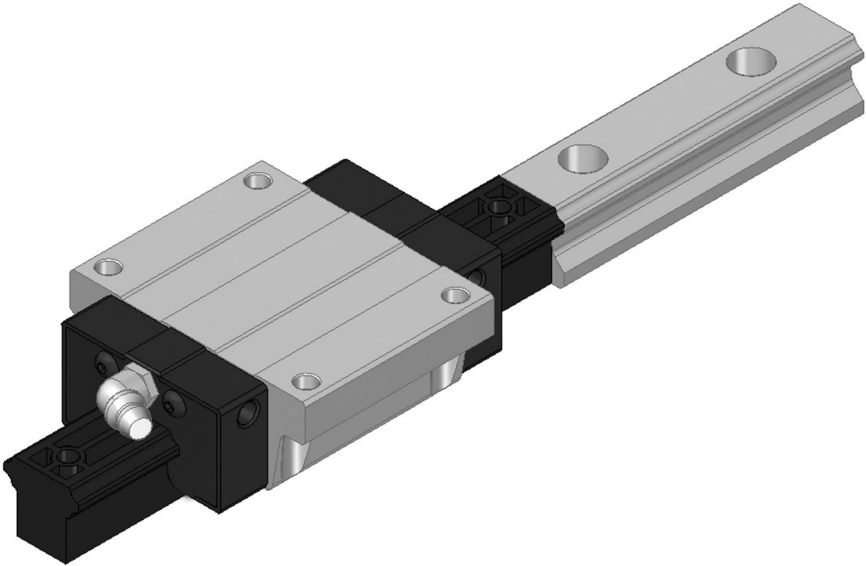

14 Instructions for Handling

1. Handling

- 1) The packaged WON Linear Motion guide is damp-proof after grease removal and cleaning, so please open it just before use.
- 2) The rail-block compatible product is fitted with a plastic support rail. Please take caution when assembling it with the rail.
- 3) If you reassemble a block-rail set product or a single block product after dismantling it into pieces, foreign substance may intrude into the block, decreasing performance to make rolling motion unsmooth or damaged. So please do not disassemble it.
- 4) If either a rail or a block leans to one side, the block or the rail may fall to be damaged. Please take caution and avoid the deviation of the block or the rail.
- 5) The end plate may be damaged if impact is applied since it is made of plastic material. Please be careful.

2. Lubrication

- 1) If the product is supplied as it is applied by rust preventive oil, please clean it off thoroughly and fill lubricant prior to use.
- 2) Do not mix it with other lubricants such as thickener or additive. If so, it may destroy the structure of grease or cause a harmful effect.
- 3) Viscosity of grease may vary depending on temperature and increase in winter due to low temperature, and the friction resistance of Linear Motion guide may increase.
- 4) In case of using special lubricant, please contact WON in advance.
- 5) In case of using oil lubricant, it may not reach the hole of raceway depending on the assembly status or direction of a block and a rail, so no lubricating effect may be obtained. WON can offer the lubricating method suitable for each assembly environment so please contact WON.

3. Caution for Use

- 1) After opening the product, please put damp-proof agent inside the dry container for storage.
- 2) Please handle the product after wearing plastic gloves in a clean place.
- 3) Please be careful to protect it from foreign substance which may inhibit rolling motion or damage function.
- 4) Please protect it using a holding door or cover to prevent Linear Motion guide exposed directly to poor environment that may cause corrosion or damage.
- 5) In case of using standard plastic end plate-based Linear Motion guide, use it at under 80°C. To use it at higher temperature than 80°C, please order a metal end plate which will specially customized.
- 6) If the rail of Linear Motion guide is fixed at the ceiling or in high place and if the block bears load downwards, the end plate may be destroyed or a ball may come off from the rail resulting in the fall of the block and fixtures. So please take a measure to install a safety device.

4. Storage

Depending on storage conditions, a rail may warp. For storage, place it in a horizontal position in the package box provided by WON or in a similar box with the flat bottom and avoid the environments where temperature is too high or low and very humid.

Cause and Countermeasure of Damage of Linear Motion Guide

Condition		Cause	Countermeasures
Fatigue failure on the rolling surface	<ul style="list-style-type: none"> Flaking - Caused by rolling fatigue on the rolling surface - Maximum shear stress-induced internal cracks are expressed on the surface. 	Damage by life	Change Linear Motion guide
		Overload	Reconsider the model no. selected, use higher model no, lower the load level, reinforce the assembly precision during installation, enhance the rigidity of base and table
		Poor lubrication	Refill lubricant, shorten the refilling interval of lubricant, review the relevance of lubricant in use, improve the lubricant passage
Indentation of the rolling surface	<ul style="list-style-type: none"> Indentation - Plastic deformation on the rolling surface due to excessive external load 	Impact load or excessive external load	Reconsider the model no. selected, lower the load level, reinforce the assembly precision during installation, use the higher model no.
		Careless handling	Prevent impact and fall during handling Improve handling method and environment
Seizing	<ul style="list-style-type: none"> Burn - Rough surface of the rolling surface due to slight burning by friction between a rolling element and the rolling surface - Cause for the discoloration of the rolling surface, weakened hardness, and flaking 	Poor lubrication	Refill lubricant, use the optimal lubricant, improve the lubrication method
		Overload	Review the service conditions, lower the load level, use the higher model no. enhance the assembly precision during installation
Cracking	<ul style="list-style-type: none"> Cracking - Partial breaking into pieces of a rolling element or rolling surface due to excessive external load 	Impact load or excessive external load	Reconsider the model no. selected, use the higher model no. lower the load level, enhance the assembly precision during installation
		Poor raceway circulation of a rolling element	Prevent the intrusion of foreign substance, develop a dust proof measure, refill lubricant, shorten the refilling interval of lubricant, improve the lubrication method
Abnormal wear	<ul style="list-style-type: none"> Abnormal wear - Rapid increase in wear as the slippery between a rolling element and the rolling surface - Cause for failure in precision and pre-load as accompanied by oxidation wear 	Excessive load or excessive eccentric load	Reconsider the model no. selected, use the higher model no., lower the load level, enhance the assembly precision during installation
		Foreign substance	Complement the performance of seal, develop a dust proof measure
		substance	Refill lubricant, use the optimal lubricant, improve the lubrication method, improve the lubricant passage
Flattening corrosion	<ul style="list-style-type: none"> Vibration - Wear facilitated by the loss of oil film during the running of vibrant stroke and the slippery between a rolling element and the rolling element 	Load	Review the service conditions, use the higher model no., enhance the assembly precision during installation
		Vibration	Improve the transport condition, change lubricant, improve the lubrication method, shorten the refilling interval of lubricant
		Foreign substance	Complement the performance of seal, develop a dust proof measure
Rust prevention	<ul style="list-style-type: none"> Rust - Caused by the loss of oil film or contact of exposed part to water, acid, alkali and especially when cooling water enters into the block; cause for early flaking due to concentrated stress 	Intrusion of cooling water	Make a rust-preventive treatment onto the surface, complement the performance of seal, change lubricant, change cooling agent, refill lubricant, shorten the refilling interval of lubricant
		High humidity	Make a rust-preventive treatment onto the surface, improve environment
		Poor handling	Improve the condition of storage, reinforce the sealing performance, apply sufficient amount of rust-preventive oil

<Comparison Table of Full-Ball Type Model No. of Other Manufacturers>

1. H Series(Standard Type)

WON	THK	NSK	PMI	HIWIN
H 15F H 15FL	HSR 15A, B	LH 15EL, EM LH 15GL, GM	MSA 15A	HGW 15CA
H 20F H 20FL	HSR 20A, B HSR 20LA, LB	LH 20EL, EM LH 20GL, GM	MSA 20A MSA 20LA	HGW 20CA HGW 20HA
H 25F H 25FL	HSR 25A, B HSR 25LA, LB	LH 25EL, EM LH 25GL, GM	MSA 25A MSA 25LA	HGW 25CA HGW 25HA
H 30F H 30FL	HSR 30A, B HSR 30LA, LB	LH 30EL, EM LH 30GL, GM	MSA 30A MSA 30LA	HGW 30CA HGW 30HA
H 35F H 35FL	HSR 35A, B HSR 35LA, LB	LH 35EL, EM LH 35GL, GM	MSA 35A MSA 35LA	HGW 35CA HGW 35HA
H 45F H 45FL	HSR 45A, B HSR 45LA, LB	LH 45EL, EM LH 45GL, GM	MSA 45A MSA 45LA	HGW 45CA HGW 45HA
H 55F H 55FL	HSR 55A, B HSR 55LA, LB	LH 55EL, EM LH 55GL, GM	MSA 55A MSA 55LA	HGW 55CA HGW 55HA
H 15R H 15RL	HSR 15R	LH 15AN, AL LH 15BL, BL	MSA 15S	HGH 15CA
H 20R H 20RL	HSR 20R HSR 20LR	LH 20AN, AL LH 20BN, BL	MSA 20S MSA 20LS	HGH 20CA HGH 20HA
H 25R H 25RL	HSR 25R HSR 25LR	LH 25AN, AL LH 25BN, BL	MSA 25S MSA 25LS	HGH 25CA HGH 25HA
H 30R H 30RL	HSR 30R HSR 30LR	LH 30AN, AL LH 30BN, BL	MSA 30S MSA 30LS	HGH 30CA HGH 30HA
H 35R H 35RL	HSR 35R HSR 35LR	LH 35AN, AL LH 35BN, BL	MSA 35S MSA 35LS	HGH 35CA HGH 35HA
H 45R H 45RL	HSR 45R HSR 45LR	LH 45AN, AL LH 45BN, BL	MSA 45S MSA 45LS	HGH 45CA HGH 45HA
H 55R H 55RL	HSR 55R HSR 55LR	LH 55AN, AL LH 55BN, BL	MSA 55S MSA 55LS	HGH 55CA HGH 55HA

2. S Series(Slim Type)

WON	THK	NSK	PMI	HIWIN
S 15C S 15R	SR 15V SR 15W	LS 15CL LS 15AL	MSB 15TS MSB 15S	EGH 15SA EGH 15CA
S 20C S 20R	SR 20V SR 20W	LS 20CL LS 20AL	MSB 20TS MSB 20S	EGH 20SA EGH 20CA
S 25C S 25R	SR 25V SR 25W	LS 25CL LS 25AL	MSB 25TS MSB 25S	EGH 25SA EGH 25CA
S 15CF S 15F	SR 15SB SR 15TB	LS 15EM LS 15JM	MSB 15TE MSB 15E	EGW 15CA EGW 15CB
S 20CF S 20F	SR 20SB SR 20TB	LS 20EM LS 20JM	MSB 20TE MSB 20E	EGW 20CA EGW 20CB
S 25CF S 25F	SR 25SB SR 25W	LS 25EM LS 25JM	MSB 25TE MSB 25E	EGW 25CA EGW 25CB

3. M Series(Miniature Standard Type)

WON	THK	NSK	PMI	HIWIN	IKO
M 5C M 5N	RSR 5M RSR 5TN	— LU 05TL	— —	MGN 5C —	LWLC 5 LWL 5
M 7C M 7N M 7L	— RSR 7M RSR 7N	— LU 07AL —	— MSC 7M MSC 7LM	— MGN 7C MGN 7H	LWLC 7 LWL 7 LWLG 7
M 9C M 9N M 9L	— RSR 9KM RSR 9N	— LU 09TL LU 09UL	— MSC 9M MSC 9LM	— MGN 9C MGN 9H	LWLC 9 LWL 9 LWLG 9
M 12C M 12N M 12L	— RSR 12VM RSR 12N	— LU 12TL LU 12UL	— MSC 12M MSC 12LM	— MGN 12C MGN 12H	LWLC 12 LWL 12 LWLG 12
M 15C M 15N M 15L	— RSR 15VM RSR 15N	— LU 15AL LU 15BL	— MSC 15M MSC 15LM	— MGN 15C MGN 15H	LWLC 15 LWL 15 LWLG 15
M 20C M 20N M 20L	— — —	— — —	— — —	— — —	LWLC 20 LWL 20 LWLG 20

4. MB Series(Miniature Wide body Type)

WON	THK	NSK	PMI	HIWIN	IKO
MB 5C	RSR 5WTM	—	—	—	LWLFC 10
MB 5N	RSR 5WTM	LE 05AL	—	—	LWLF 10
MB 7C	—	—	—	—	LWLFC 14
MB 7N	RSR 7WTM	LU 07TL	MSD 7M	MGW 7C	LWLF 14
MB 7L	RSR 7WTM	—	MSD 7LM	MGW 7H	LWLFG 14
MB 9C	—	—	—	—	LWLFC 18
MB 9N	—	LE 09TL, TR	MSD 9M	MGW 9C	LWLF 18
MB 9L	RSR 9WN	—	MSD 9LM	MGW 9H	LWLFG 18
MB 12C	—	—	—	—	LWLFC 24
MB 12N	RSR 12WV, WVM	LE 12AL, AR	MSD 12M	MGW 12C	LWLF 24
M 12L	RSR 12WN	—	MSD 12LM	MGW 12H	LWLFG 24
MB 15C	—	—	—	—	LWLFC 42
MB 15N	RSR 15WV, WVM	LE 15AL, AR	MSD 15M	MGW 15C	LWLF 42
MB 15L	RSR 15WN	—	MSD 15LM	MGW 15H	LWLFG 42



WON
LINEAR MOTION SYSTEM

Crossed Roller Bearing

Contents

1	Structure and characteristic of Crossed Roller Bearing	
1.	Structure	88
2.	Characteristics	88
3.	Use	88
2	Kind of Crossed Roller Bearing	
1.	CB series of revolving inner ring	89
2.	CH series for high stiffness	89
3.	CS series for customized special type	90
3	Selection of Crossed Roller Bearing	
1.	Selection summary	91
2.	Selection sequence	91
4	Nominal numbering	92
5	Calculation of service life	
1.	Rating life	92
2.	Calculation of service life under heaving operation condition	93
3.	Static safety factor	93
4.	Static equivalent load	94
5.	Dynamic radial load	94
6.	Load factor	95
6	Rated load	
1.	Basic static rated load	95
2.	Basic dynamic rated load	95
7	Permissible rpm	95
8	Lubrication	96
9	Cautions in designing compression plate and housing	
1.	Housing design for installation	96
2.	Tap for separation	96
3.	Installation & assembly	97
4.	Selection of compression flange and bolt	97
10	Fitting	99
11	Precision of Crossed Roller Bearing	100
12	Precision of WUP series	
1.	Rotation accuracy of WUP series (example)	104
2.	Precision standard	104
13	Radial clearance	105
14	Dimension of Crossed Roller Bearing	
1.	CB series	106
2.	CH series	108
15	Cautions when handling Crossed Roller Bearing	110



1 Structure and characteristic of Crossed Roller Bearing

1. Structure

WON Crossed Roller Bearing has the structure having rolling surface with V-grooved inner & outer ring which is crossed with roller and a spacer-type retainer between rollers reduces the friction between rollers so as to prevent rotational torque from increasing. It's a compact type for convenient use.

2. Characteristics

As roller is assembled to rolling surface of inner & outer ring of Crossed Roller Bearing, it reduces the elastic displacement by external load and accommodates the complex load including radial load, axial load and moment load and using spacer retainer avoids uneven wear by roller on inclined surface or uneven contact as well as hitching but helps rolling smoothly and it's a high precision and high stiffness type which allows pre-load depending surrounding environment.

3. Use

It's optimal to the use requiring complex load and high stiffness.

The uses are industrial robot, machine tool index table, ATC, medical equipment, precise alignment stage, semiconductor manufacture equipment, DD motor and others

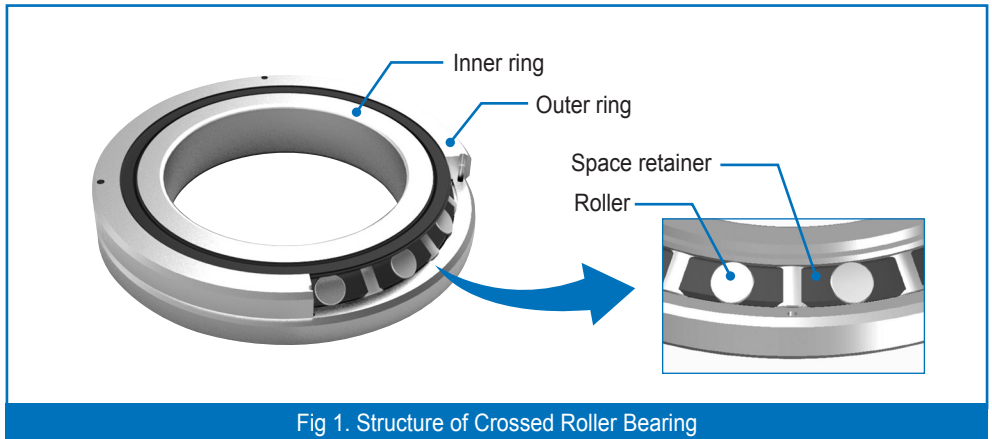

Fig 1. Structure of Crossed Roller Bearing

2 Kind of Crossed Roller Bearing

1. CB series of revolving inner ring.

- 1) Inner ring of Crossed Roller Bearing is integral type while outer ring is separable to upper and lower part which is bolted for easy handling
- 2) It's used for the part requiring inner ring rotating such as index table of machine tool or joint or turning part of industrial robot



2. High stiffness CH series

- 1) Inner & outer ring are integral, high precision and high stiffness type with less installation error which leads to stable running accuracy
- 2) It's used for the part requiring inner & outer ring rotating simultaneously or independently



3. CS series for customized special type

- 1) It's customized to meet customer's own requirements in shape, dimension and material of inner & outer ring and bolt dimension.

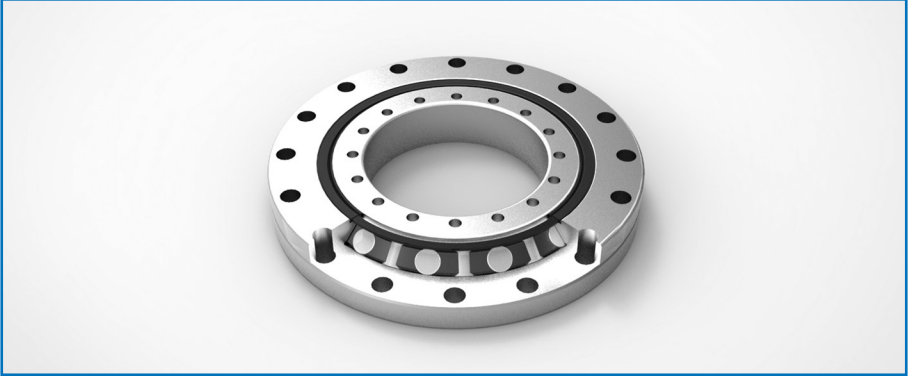









3 Selection of Crossed Roller Bearing

1. Selection summary

After identifying the requirements specifically, the priority shall be determined considering the needs and then the optimal type shall be selected

2. Selection sequence

- 1 Determination of the needs  Equipment to be used, requirements, environment, precision, stiffness, service life and others
- 2 Selection of the type  Integral type, separable inner ring, separable outer ring, normal, high stiffness
- 3 Load calculation  Supporting load including radial load, axial load, moment load and dynamic equivalent load
- 4 Calculation of rating service life  Calculation of rating service life
- 5 Calculation of static safety factor  Static safety factor considering equipment characteristic and external load
- 6 Determination of stiffness and pre-load  Determination of clearance and pre-load considering kinetic condition and rotation accuracy
- 7 Accuracy level  Determination of accuracy level considering rotation accuracy and assembly accuracy
- 8 Determination of lubrication  Determination of lubrication such as oil, grease or special lubricant
- 9 Final determination

4 Nominal numbering

Numbering system of Crossed Roller Bearing manufactured by WON comprises of model, inner/outer ring size, seal, preload and grade symbol. See the following example for details.

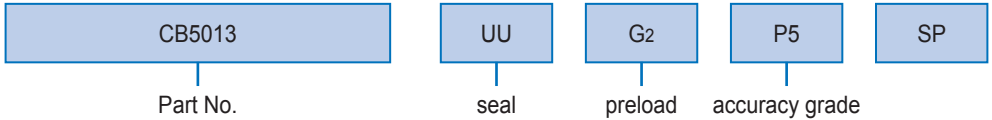

Seal		Preload		Accuracy grade	
No symbol	: no seal	G1	: normal preload	No symbol	: normal
UU	: seal at both sides	G2	: light load	P6	: High
U	: seal at one side	G3	: heavy load	P5	: accurate
				P4	: highly accurate
				P2	: Extremely accurate

5 Calculation of service life

1. Rated service life

You can calculate the rated service life of Crossed Roller Bearing by using the formula below.

$$L = \left(\frac{f_T \cdot C}{f_w \cdot P_c} \right)^{\frac{10}{3}} \times 10^6$$

service life time

$$L_h = \frac{L}{60 \times N}$$

L : rated service life

C : basic dynamic rated load(N)

P_c: dynamic equivalent radial load (N)

f_T: temperature factor

f_w: load factor

L_h: service life time(h)

N : rpm

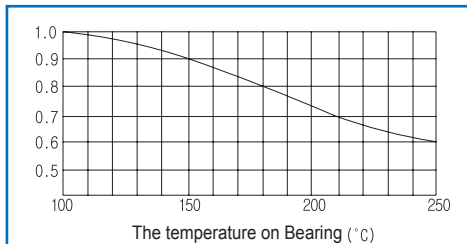

Fig 2. Temperature factor

* Note : workable temperature is 80°C or below When the temperature is more than above, please contact WON ST

2. Calculation of service life under heaving operation condition

Bearing service life under heaving condition is calculated as follows;

$$L_{0c} = \frac{90}{\theta} \left(\frac{C}{P_c} \right)^P$$

L_{0c} : rated service life 10^6 cycle indicated in bearing heaving frequency under heaving operation

θ : heaving angle (see Fig)

P_c : dynamic equivalent radial load

※ when θ is small, oil film can hardly be formed on contact surface between orbital plane and rotating body so it may cause corrosion

In case of heaving operation

Service life time

$$L_h = \frac{360 \times L}{2 \times \theta \times n_o \times 60}$$

L_h : service life time (h)

θ : heaving angle (deg)

(※ see Fig on right)

n_o : number of reciprocating motion (min^{-1})

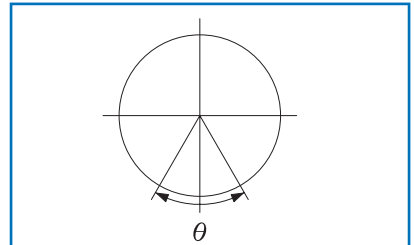

Fig 3.

3. Static safety factor(f_s)

Static safety factor of Crossed Roller Bearing is calculated as follows.

Please see Table 1 for static safety factor in general

$$f_s = \frac{C_0}{P_0}$$

f_s : static safety factor

C_0 : basic static rated load (N)

P_0 : static equivalent radial load (maximum load) (N)

Table 1 static safety factor (f_s)

Working condition	f_s Lower bound
Requires high running accuracy	≥ 3
When using under normal operation condition	≥ 2
Few rotation under normal operation condition and smooth operation is less important	≥ 1

4. Static equivalent load (P_0)

Static equivalent load of Crossed Roller Bearing is calculated as follows

$$P_0 = F_r + \frac{2M}{D_{PW}} + 0.44 F_a$$

P_0 : Static equivalent radial load (N)

F_r : Radial load (N)

F_a : Axial load (N)

M : Moment (N·mm)

D_{PW} : Roller set pitch diameter ($D_{PW} \doteq \frac{d+D}{2}$)

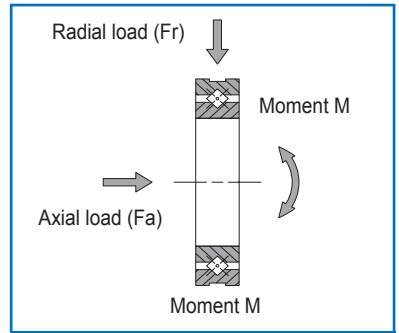

Fig 4. Bearing load

5. Dynamic equivalent radial load (P_c)

Dynamic equivalent radial load of Crossed Roller Bearing is calculated using following equation

$$P_c = X \left(F_r + \frac{2M}{D_{PW}} \right) + Y F_a$$

P_c : Dynamic equivalent radial load (N)

F_r : Radial load (N)

F_a : Axial load (N)

M : Moment (N·mm)

X : Radial load factor (see Table 2)

Y : Axial load factor (see Table 2)

D_{PW} : Roller set pitch diameter ($D_{PW} \doteq \frac{d+D}{2}$)

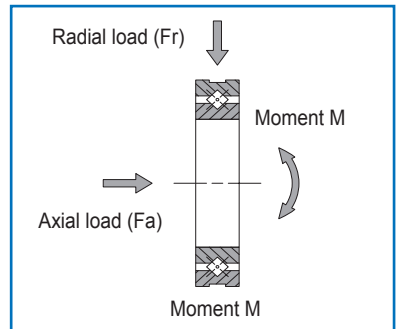

Fig 5.

Table 2. Radial load factor and axial load factor

Classification	X	Y
$\frac{F_a}{F_r + 2M/D_{PW}} \leq 1.5$	1	0.45
$\frac{F_a}{F_r + 2M/D_{PW}} > 1.5$	0.67	0.67

6. Load factor (f_w)

When using Crossed Roller Bearing, the load imposed on bearing by vibration and impact during operation is often greater than calculated load. Thus flowing load factors need to be considered when selecting the bearing.

$$F = F_c \cdot f_w$$

F : bearing load (N)

F_c : theoretical load factor (N)

f_w : load factor

Table 3. Load factor(f_w)

Load condition	f_w
Smooth condition without impact	1 ~ 1.2
Normal condition	1.2 ~ 1.5
Vibration and impact load together during operation	1.5 ~ 3

6 Static load

1. Basic dynamic rated load (C)

It refers to radial load with a constant size and direction which is able to rotate a million times with more than 90% proved no flaking occurred due to rolling fatigue when driving a bearing group comprising a number of same crossed roller bearing

2. Basic static rated load (C_0)

It refers to the static radial load which imposes a certain level of contact stress on center of contact part of revolving body and orbital plane exposed to maximum load

7 Permissible rpm

Please see the following table for permissible rpm

But permissible rpm may vary depending on assembly and working condition

Table 4. Permissible rpm of Crossed Roller Bearing ($d_m n$)

Bearing	Classification	Seal	Grease	Oil
Bearing		No seal	75,000	150,000
Spacer retainer		Both seals	60,000	-

$$\ast d_m n = d_m \times n$$

d_m : mean value of bearing inner and outer ring (mm)

n : rpm

8 Lubrication

Grease lubrication is commonly used for Crossed Roller Bearing and lubricant is injected through oil inlet. Albanian EP2 grease is filled
 Bearing without lubricant shall be filled with grease or oil prior to starting operation, otherwise, wearing is accelerated and service life is reduced.

9 Cautions in designing compression plate and housing

Crossed roller bearing is compact and slim and thus plate and housing stiffness and bolt torque shall be evaluated when designing the installation.
 Should the stiffness of the plate or housing be insufficient, tight assembly of inner and outer ring would be difficult and deformation by moment load causes uneven contact and poor performance significantly.

1. Housing design for installation

Housing thickness shall be more than 60% of bearing section height

$$T = \frac{D-d}{2} \times 0.6 \text{height}$$

T : housing thickness
 D : outer ring dimension
 d : inner ring dimension

2. Tap for separation

Separation tap would help separate the inner & outer ring without damage to bearing

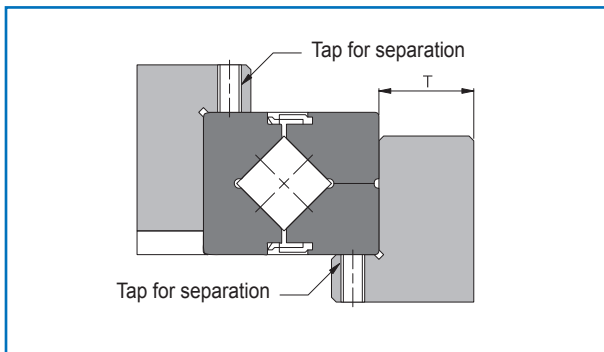

Fig 6.

3. Installation & assembly

Please see the Fig below for installation & assembly

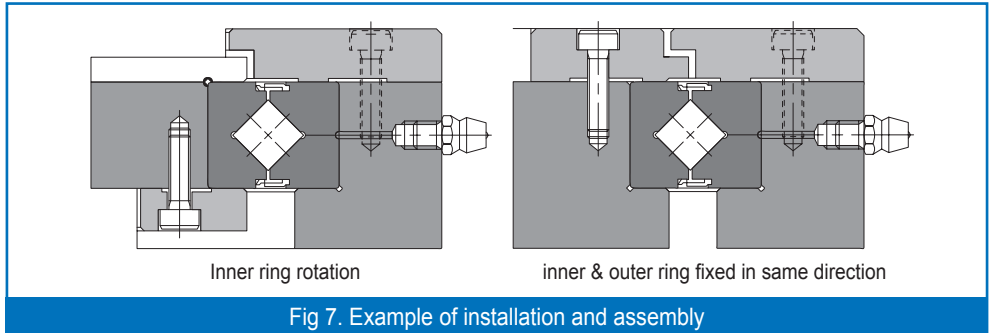

Fig 7. Example of installation and assembly

4. Selection of compression flange and bolt

The more compression bolt, the higher the stability. See Table 5 for layout
Please see the Table below for flange thickness (F) and gap (S)

$$F = B \times 0.5 \sim B \times 1.2$$

$$H = B \begin{matrix} 0 \\ -0.1 \end{matrix}$$

$$S = 0.5\text{mm}$$

Bolts shall be tightened with appropriate torque to prevent them from loosened and when axis and housing are in a light alloy, steel shall be used.

When using common medium or hard steel, please refer to the Table below

Table 5. No and size of compression bolt Unit : mm

An external diameter of Outer ring(D)		Number of bolt	Bolt size
More	Less		
-	100	8 or more	M3 ~ M5
100	200	12 or more	M4 ~ M8
200	300	16 or more	M5 ~ M12

Table 6. Maximum clamping torque of bolt Unit : N•m

Symbol	Clamping Torque	Symbol	Clamping Torque
M3	2	M8	30
M4	4	M10	70
M5	9	M12	120
M6	14	-	-

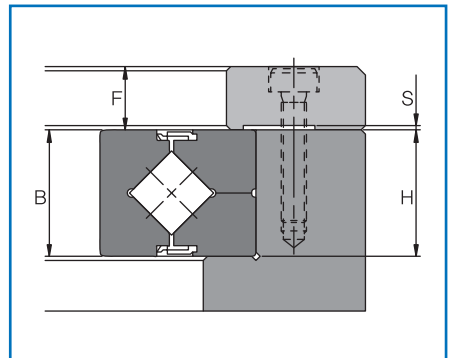

Fig 8.

※ Assembly sequence

Assembly sequence of Crossed Roller Bearing is as follows

1. Pre-inspection before assembly

Check to ensure no contaminant, scratch or sharp edge in housing or parts

2. Assembly of axis or housing

Because the bearing is compact type, it's easily inclined during assembly process and thus it shall be inserted gradually after making it horizontally balanced using plastic hammer and while hammering the circumference of outer ring till the part is set in place completely

3. Installation of compression flange

- 1) After putting the flange in place, it shall be assembled while checking the bolt if it's in right place
- 2) Bolt shall be tightened after confirming the bolts are in place accurately
- 3) Bolt shall be tightened over two to 5 stages from temporary tightening till complete tightening. In case that inner ring and outer ring are separated, check the position while turning the integral axis slowly and tighten the bolts over two to five stages gradually.

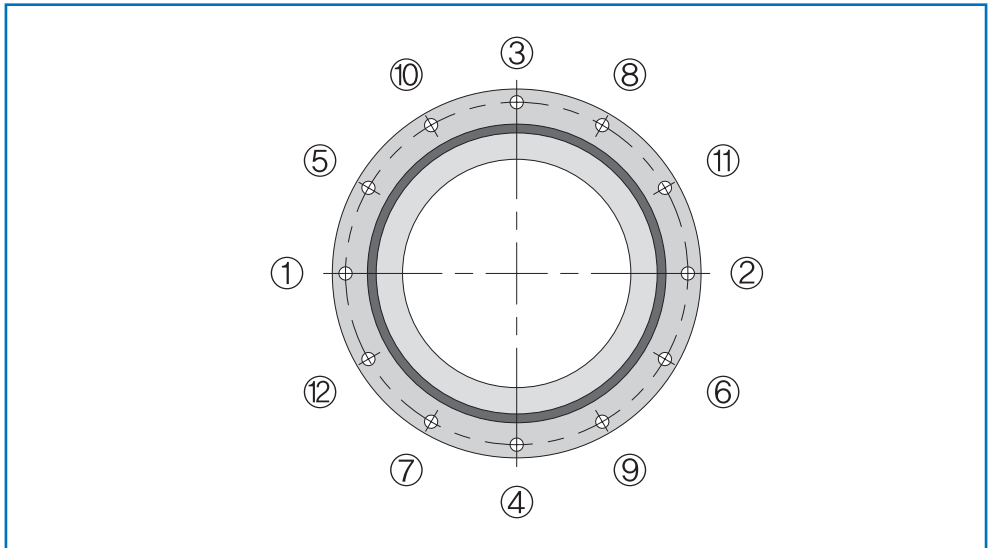

Fig 9.

10 Fitting

Please refer to the Table below for fitting

Table 7. Recommended fitting under average load

Radial internal gap	Tolerance range class			
	Load fixed to inner ring rotation		Load fixed to outer ring rotation	
	Axis	Housing hole	Axis	Housing hole
G ₁ gap	h5	H7	g5	J7 ⁽¹⁾
G ₂ gap	j5	H7	g5	J7 ⁽¹⁾

Note⁽¹⁾ small edge joint according to measured value is recommended

Table 8. Recommended fitting for normal gap of slip type

Bearing internal diameter (d) mm	Load fixed to inner ring rotation				Load fixed to outer ring rotation			
	Axis		Housing hole		Axis		Housing hole	
	top	bottom	top	bottom	top	bottom	top	bottom
50	+15	0	+13	0	-15	-30	-13	-25
60	+15	0	+13	0	-15	-30	-13	-25
70	+15	0	+15	0	-15	-30	-15	-30
80	+20	0	+15	0	-20	-40	-15	-30
90	+20	0	+15	0	-20	-40	-15	-30
100	+20	0	+15	0	-20	-40	-15	-30
110	+20	0	+20	0	-20	-40	-20	-40
120	+25	0	+20	0	-25	-50	-20	-40
130	+25	0	+25	0	-25	-50	-25	-50
140	+25	0	+25	0	-25	-50	-25	-50
150	+25	0	+25	0	-25	-50	-25	-50
160	+25	0	+25	0	-25	-50	-25	-50
170	+25	0	+30	0	-25	-50	-30	-60
180	+30	0	+30	0	-30	-60	-30	-60
190	+30	0	+30	0	-30	-60	-30	-60
200	+30	0	+30	0	-30	-60	-30	-60

11 Precision of Crossed Roller Bearing

Precision and tolerance of Crossed Roller Bearing are in accordance with Table 9 through 17.

Table 9. CH series inner ring rotation accuracy

Unit : μm

Part No.	Inner ring radial swing tolerance			Inner ring axis swing tolerance		
	Precision	High precision	Ultra high precision	Precision	High precision	Ultra high precision
	P5	P4	P2	P5	P4	P2
CH42	4	3	2.5	4	3	2.5
CH66	5	4	2.5	5	4	2.5
CH85	5	4	2.5	5	4	2.5
CH124	5	4	2.5	5	4	2.5
CH148	6	5	2.5	6	5	2.5
CH178	6	5	2.5	6	5	2.5
CH228	8	6	5	8	6	5
CH297	10	8	5	10	8	5
CH445	15	12	7	15	12	7

Note(1) : Standard rotation accuracy of CH series is P5

Table 10. CH series outer ring rotation accuracy

Unit : μm

Part No.	Outer ring radial swing tolerance			Outer ring axis swing tolerance		
	Precision	High precision	Ultra high precision	Precision	High precision	Ultra high precision
	P5	P4	P2	P5	P4	P2
CH42	8	5	4	8	5	4
CH66	10	6	5	10	6	5
CH85	10	6	5	10	6	5
CH124	13	8	5	13	8	5
CH148	15	10	7	15	10	7
CH178	15	10	7	15	10	7
CH228	18	11	7	18	11	7
CH297	20	13	8	20	13	8
CH445	25	16	10	25	16	10

Note(1) : Standard rotation accuracy of CH series is P5

Table 11. CB series inner ring rotation accuracy

Unit : μm

Nominal dimension of bearing internal diameter(mm)		Inner ring radial swing tolerance					Inner ring axis swing tolerance				
		0	PE6	PE5	PE4	PE2	0	PE6	PE5	PE4	PE2
			P6	P5	P4	P2		P6	P5	P4	P2
More	Less										
18	30	13	8	4	3	2.5	13	8	4	3	2.5
30	50	15	10	5	4	2.5	15	10	5	4	2.5
50	80	20	10	5	4	2.5	20	10	5	4	2.5
80	120	25	13	6	5	2.5	25	13	6	5	2.5
120	150	30	18	8	6	2.5	30	18	8	6	2.5
150	180	30	18	8	6	5	30	18	8	6	5
180	250	40	20	10	8	5	40	20	10	8	5
250	315	50	25	13	10	(6)	50	25	13	10	(6)
315	400	60	30	15	12	(7)	60	30	15	12	(7)
400	500	65	35	18	14	(9)	65	35	18	14	(9)
500	630	70	40	20	16	(10)	70	40	20	16	(10)
630	800	80	(45)	(23)	(18)	(11)	80	(45)	(23)	(18)	(11)
800	1000	90	(50)	(25)	(20)	(12)	90	(50)	(25)	(20)	(12)

Table 12. Dimensional tolerance of bearing internal diameter

Unit : μm

Nominal dimension of bearing internal diameter (d)(mm)		Tolerance of $dm^{\text{note(2)}}$							
		0, P6, P5, P4, P2, WJP		PE6		PE5		PE4, PE2	
More	Less	top	bottom	top	bottom	top	bottom	top	bottom
18	30	0	-10	0	-8	0	-6	0	-5
30	50	0	-12	0	-10	0	-8	0	-6
50	80	0	-15	0	-12	0	-9	0	-7
80	120	0	-20	0	-15	0	-10	0	-8
120	150	0	-25	0	-18	0	-13	0	-10
150	180	0	-25	0	-18	0	-13	0	-10
180	250	0	-30	0	-22	0	-15	0	-12
250	315	0	-35	0	-25	0	-18	-	-
315	400	0	-40	0	-30	0	-23	-	-
400	500	0	-45	0	-35	-	-	-	-
500	630	0	-50	0	-40	-	-	-	-
630	800	0	-75	0	-	-	-	-	-
800	1000	0	-100	-	-	-	-	-	-

Note(1) : Standard internal diameter of CH series is 0 class, Please contact WON ST for higher class

Note(2) : dm refers to mean value between max diameter and min diameter of 2 points of bearing

Note(3) : In case of no precision class indicated, the highest value of the low precision class is applied

Table 13. Dimensional tolerance of bearing external diameter

Unit : μm

Nominal dimension of bearing internal diameter (d)(mm)		Tolerance of $dm^{\text{note(2)}}$							
		0, P6, P5, P4, P2, WJP		PE6		PE5		PE4, PE2	
More	Less	top	bottom	top	bottom	top	bottom	top	bottom
30	50	0	-11	0	-9	0	-7	0	-6
50	80	0	-13	0	-11	0	-9	0	-7
80	120	0	-15	0	-13	0	-10	0	-8
120	150	0	-18	0	-15	0	-11	0	-9
150	180	0	-25	0	-18	0	-13	0	-10
180	250	0	-30	0	-20	0	-15	0	-11
250	315	0	-35	0	-25	0	-18	0	-13
315	400	0	-40	0	-28	0	-20	0	-15
400	500	0	-45	0	-33	0	-23	-	-
500	630	0	-50	0	-38	0	-28	-	-
630	800	0	-75	0	-45	0	-35	-	-
800	1000	0	-100	-	-	-	-	-	-

Note(1) : Standard internal diameter of CH series is 0 class, Please contact WON ST for higher class

Note(2) : dm refers to mean value between max diameter and min diameter of 2 points of bearing

Note(3) : In case of no precision class indicated, the highest value of the low precision class is applied

Table 14 Tolerance of inner & outer ring width of CH series

Unit : μm

Part No.	Tolerance of B	
	Top	Bottom
CH42	0	-75
CH66	0	-75
CH85	0	-75
CH124	0	-75
CH148	0	-75
CH178	0	-100
CH228	0	-100
CH297	0	-100
CH445	0	-150

Table 15. Tolerance of inner & outer ring width of CB series

Unit : μm

Nominal dimension of bearing internal diameter (d) (mm)		Tolerance of B		Tolerance of B ₁	
		Applied to CB outer ring		Applied to CB inner ring	
More	Less	Top	bottom	Top	bottom
18	30	0	-75	0	-100
30	50	0	-75	0	-100
50	80	0	-75	0	-100
80	120	0	-75	0	-100
120	150	0	-100	0	-120
150	180	0	-100	0	-120
180	250	0	-100	0	-120
250	315	0	-120	0	-150
315	400	0	-150	0	-200
400	500	0	-150	0	-200
500	630	0	-150	0	-200
630	800	0	-150	0	-200
800	1000	0	-300	0	-400

12 Precision of WUP class

1. Rotation accuracy of WUP class of Crossed Roller Bearing (example)

Precision of WUP class is in accordance with ISO Class 2, DIN P2, AFBMA, ABCE9 ad JIS 2 or greater

2. Precision standard

Swing precision of CH, CB and WUP series of Crossed Roller Bearing is in accordance with Table 16 & 17

Table 16. Swing precision of WUP class of CH series

Unit : μm

Part No.	Inner ring swing precision of CH		Outer ring swing precision of CH	
	Radial swing tolerance	Axial swing tolerance	Radial swing tolerance	Axial swing tolerance
CH42	2	2	3	3
CH66	2	2	3	3
CH85	2	2	3	3
CH124	2	2	3	3
CH148	2	2	4	4
CH178	2	2	4	4
CH228	2.5	2.5	4	4
CH297	3	3	5	5
CH445	4	4	7	7

Table 17. Swing precision of WUP class of CB series

Unit : μm

Part No.		Swing precision of inner ring of CB series	
More	less	Radial swing tolerance	Axial swing tolerance
80	180	2.5	2.5
180	250	3	3
250	315	4	4
315	400	4	4
400	500	5	5
500	630	6	6
630	800	-	-

13 Radial clearance

Radial clearance of CH series and CB series is as follows

Table 18. Radial clearance of CH series

Unit : μm

Part No.	G ₃		G ₂	
	Starting torque (N·m)		Radial clearance (μm)	
	Minimum	Maximum	Minimum	Maximum
CH42	0.1	0.5	0	25
CH66	0.3	2.2	0	30
CH85	0.4	3	0	40
CH124	1	6	0	40
CH148	1	10	0	40
CH178	3	15	0	50
CH228	5	20	0	60
CH297	10	35	0	70
CH445	20	55	0	100

Note : G₃ clearance of CH series is controlled by starting torque and starting torque of G₃ clearance is in the status without seal resistance

Table 19. Radial clearance of WUP class of CB series

Unit : μm

Pitch diameter of roller (dp)(mm)		G ₃		G ₂	
More	Less	Minimum	Maximum	Minimum	Maximum
120	160	-10	0	0	40
160	200	-10	0	0	50
200	250	-10	0	0	60
250	280	-15	0	0	80
280	315	-15	0	0	100
315	355	-15	0	0	110
355	400	-15	0	0	120
400	500	-20	0	0	130
500	560	-20	0	0	150
560	630	-20	0	0	170
630	710	-20	0	0	190

Table 20. Radial clearance of CB series

Unit :

Pitch diameter of roller (dp)(mm)		G ₃		G ₂		G ₁	
More	Less	Minimum	Maximum	Minimum	Maximum	Minimum	Maximum
18	30	-8	0	0	15	15	35
30	50	-8	0	0	25	25	50
50	80	-10	0	0	30	30	60
80	120	-10	0	0	40	40	70
120	140	-10	0	0	40	40	80
140	160	-10	0	0	40	40	90
160	180	-10	0	0	50	50	100
180	200	-10	0	0	50	50	110
200	225	-10	0	0	60	60	120
225	250	-10	0	0	60	60	130
250	280	-15	0	0	80	80	150
280	315	-15	0	30	100	100	170
315	355	-15	0	30	110	110	190

Unit : μm

Pitch diameter of roller (dp)(mm)		G ₃		G ₂		G ₁	
More	Less	Minimum	Maximum	Minimum	Maximum	Minimum	Maximum
355	400	-15	0	30	120	120	210
400	450	-20	0	30	130	130	230
450	500	-20	0	30	130	130	250
500	560	-20	0	30	150	150	280
560	630	-20	0	40	170	170	310
630	710	-20	0	40	190	190	350
710	800	-30	0	40	210	210	390
800	900	-30	0	40	230	230	430
900	1000	-30	0	50	260	260	480
1000	1120	-30	0	60	290	290	530
1120	1250	-30	0	60	320	320	580
1250	1400	-30	0	70	350	350	630

14 Dimension of Crossed Roller Bearing

1. CB series

- Standard type, inner ring rotating outer ring separable structure

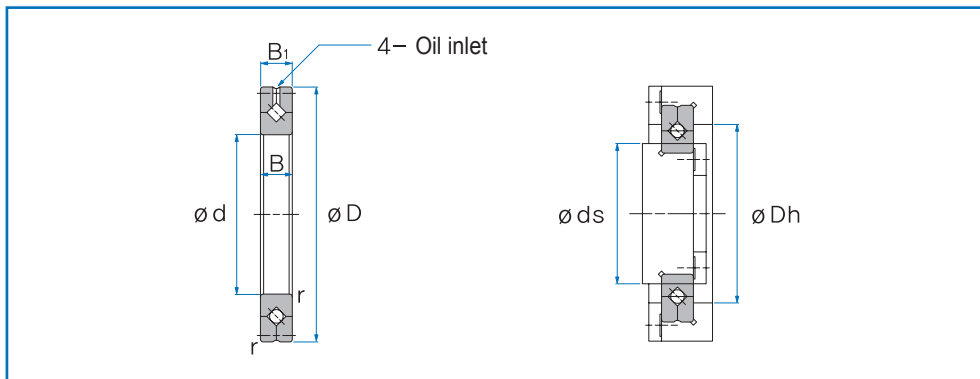

Unit : mm

Axia diameter	Part No.	Major dimension							Assembly size		Basic rated load (radial)		Mass kg
		I/D d	O/D D	Pitch dia dp	W B B ₁	Oil inlet		r ^{min}	ds	Dh	C kN	C ₀ kN	
						a	b						
20	CB 2008	20	36	27	8	2	0.8	0.5	23.5	30.5	3.23	3.1	0.04
25	CB 2508	25	41	32	8	2	0.8	0.5	28.5	35.5	3.63	3.83	0.05
30	CB 3010	30	55	41.5	10	2.5	1	0.6	37	47	7.35	8.36	0.12
35	CB 3510	35	60	46.5	10	2.5	1	0.6	41	51.5	7.64	9.12	0.13
40	CB 4010	40	65	51.5	10	2.5	1	0.6	47.5	57.5	8.33	10.6	0.16
45	CB 4510	45	70	56.5	10	2.5	1	0.6	51	61.5	8.62	11.3	0.17
50	CB 5013	50	80	64	13	2.5	1.6	0.6	57.4	72	16.7	20.9	0.27
60	CB 6013	60	90	74	13	2.5	1.6	0.6	68	82	18	24.3	0.3
70	CB 7013	70	100	84	13	2.5	1.6	0.6	78	92	19.4	27.7	0.35
80	CB 8016	80	120	98	16	3	1.6	0.6	91	111	30.1	42.1	0.7
90	CB 9016	90	130	108	16	3	1.6	1	98	118	31.4	45.3	0.75
100	CB 10016	100	140	119.3	16	3.5	1.6	1	109	129	31.7	48.6	0.83
	CB 10020		150	123	20	3.5	1.6	1	113	133	33.1	50.9	1.45
110	CB 11012	110	135	121.8	12	2.5	1	0.6	117	127	12.5	24.1	0.4
	CB 11015		145	126.5	15	3.5	1.6	0.6	122	136	23.7	41.5	0.75
	CB 11020		160	133	20	3.5	1.6	1	120	143	34	54	1.56
120	CB 12016	120	150	134.2	16	3.5	1.6	0.6	127	141	24.2	43.2	0.72
	CB 12025		180	148.7	25	3.5	2	1.5	133	164	66.9	100	2.62

1N ≅ 0.102kgf

Unit : mm

Axia diameter	Part No.	Major dimension							Assembly size		Basic rated load (radial)		Mass kg
		ID d	O/D D	Pitch dia dp	W BB ₁	Oil inlet		r min	ds	Dh	C kN	C ₀ kN	
						a	b						
130	CB 13015	130	160	144.5	15	3.5	1.6	0.6	137	152	25	46.7	0.72
	CB 13025		190	158	25	3.5	2	1.5	143	174	69.5	107	2.82
140	CB 14016	140	175	154.8	16	2.5	1.6	1	147	162	25.9	50.1	1
	CB 14025		200	168	25	3.5	2	1.5	154	185	74.8	121	2.96
150	CB 15013	150	180	164	13	2.5	1.6	0.6	157	172	27	53.5	0.68
	CB 15025		210	178	25	3.5	2	1.5	164	194	76.8	128	3.16
	CB 15030		230	188	30	4.5	3	1.5	173	211	100	156	5.3
160	CB 16025	160	220	188.6	25	3.5	2	1.5	173	204	81.7	135	3.14
170	CB 17020	170	220	191	20	3.5	1.6	1.5	184	198	29	62.1	2.21
180	CB 18025	180	240	210	25	3.5	2	1.5	195	225	84	143	3.44
190	CB 19025	190	240	211.9	25	3.5	1.6	1	202	222	41.7	82.9	2.99
200	CB 20025	200	260	230	25	3.5	2	2	215	245	84.2	157	4
	CB 20030		280	240	30	4.5	3	2	221	258	114	200	6.7
	CB 20035		295	247.7	35	5	3	2	225	270	151	252	9.6
	CB 22025		220	280	250.1	25	3.5	2	2	235	265	92.3	171
240	CB 24025	240	300	269	25	3.5	2	2.5	256	281	68.3	145	4.5
250	CB 25025	250	310	277.5	25	3.5	2	2.5	265	290	69.3	150	5
	CB 25030		330	287.5	30	4.5	3	2.5	269	306	126	244	8.1
	CB 25040		355	300.7	40	6	3.5	2.5	275	326	195	348	14.8
300	CB 30025	300	360	328	25	3.5	2	2.5	315	340	76.3	178	5.9
	CB 30035		395	345	35	5	3	2.5	322	368	183	367	13.4
	CB 30040		405	351.6	40	6	3.5	2.5	326	377	212	409	17.2
350	CB 35020	350	400	373.4	20	3.5	1.6	2.5	363	383	54.1	143	3.9
400	CB 40035	400	480	440.3	35	5	3	2.5	422	459	156	370	14.5
	CB 40040		510	453.4	40	6	3.5	2.5	428	479	241	531	23.5
450	CB 45025	450	500	474	25	3.5	1.6	1	464	484	61.7	182	6.6
500	CB 50025	500	550	524.2	25	3.5	1.6	1	514	534	65.5	201	7.3
	CB 50040		600	548.8	40	6	3	2.5	526	572	239	607	26
	CB 50050		625	561.6	50	6	3.5	2.5	536	587	267	653	41.7
600	CB 60040	600	700	650	40	6	3	3	627	673	264	721	29
700	CB 70045	700	815	753.5	45	6	3	3	731	777	281	836	46
800	CB 80070	800	950	868.1	70	6	4	4	836	900	468	1330	105
900	CB 90070	900	1050	969	70	6	4	4	937	1001	494	1490	120

1N ≙ 0.102kgf

2. CH series

- High stiffness, inner & outer ring integrated structure

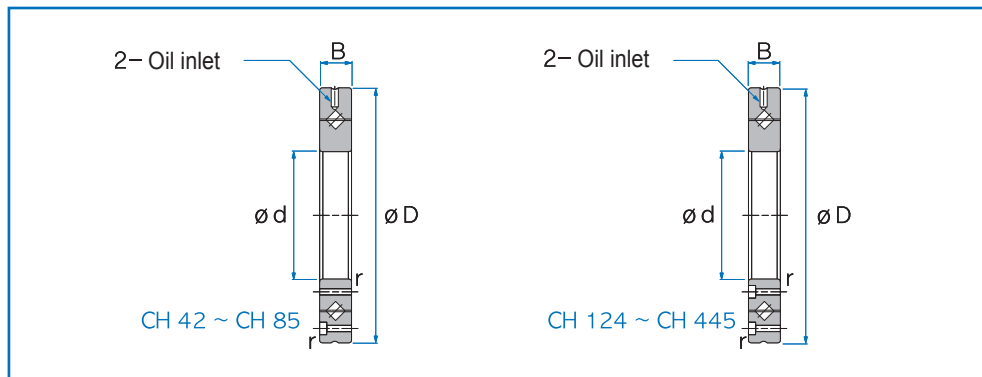

Unit : mm

Axia diameter	Part No.	Major dimension						Assembly size		Basic rated load (radial)		Mass kg
		I/D d	OD D	Pitch dia dp	W B	Oil inlet		ds	Dh	C kN	C ₀ kN	
						d ₁	r min					
20	CH42	20	70	41.5	12	3.1	0.6	37	47	7.35	8.35	0.29
35	CH66	35	95	66	15	3.1	0.6	59	74	17.5	22.3	0.62
55	CH85	55	120	85	15	3.1	0.6	79	93	20.3	29.5	1
80	CH 124(G)	80	165	124	22	3.1	1	114	134	33.1	50.9	2.6
	CH 124X											
90	CH 148(G)	90	210	147.5	25	3.1	1.5	133	162	49.1	76.8	4.9
	CH 148X											
115	CH 178(G)	115	240	178	28	3.1	1.5	161	195	80.3	135	6.8
	CH 178X											
160	CH 228(G)	160	295	227.5	35	6	2	208	246	104	173	11.4
	CH 228X											
210	CH 297(G)	210	380	297.3	40	6	2.5	272	320	156	281	21.3
	CH 297X											
350	CH 445(G)	350	540	445.4	45	6	2.5	417	473	222	473	35.4
	CH 445X											

1N ≅ 0.102kgf

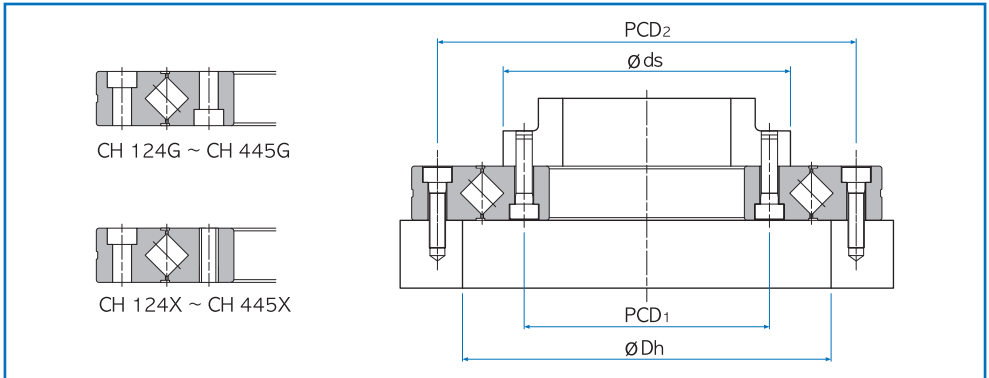

Unit : mm

Axia diameter	Part No.	Inner ring		Inner ring	
		PCD ₁	Fixing hole	PCD ₂	Fixing hole
20	CH42	28	6-M3 penetrated	57	10-ø5.5 penetrated, ø9.5 counter bore, depth 5.4
35	CH66	45	8-M4 penetrated	83	8-ø4.5 penetrated, ø8 counter bore, depth 4.4
55	CH85	65	8-M5 penetrated	105	8-ø5.5 penetrated, ø9.5 counter bore, depth 5.4
80	CH 124(G)	97	10-ø5.5 penetrated, ø9.5 counter bore, depth 5.4	148	10-ø5.5 penetrated, ø9.5 counter bore, depth 5.4
	CH 124X		10-M5 penetrated		
90	CH 148(G)	112	12-ø9 penetrated, ø14 counter bore, depth 8.6	187	12-ø9 penetrated, ø14 counter bore, depth 8.6
	CH 148X		12-M8 penetrated		
115	CH 178(G)	139	12-ø9 penetrated, ø14 counter bore, depth 8.6	217	12-ø9 penetrated, ø14 counter bore, depth 8.6
	CH 178X		12-M8 penetrated		
160	CH 228(G)	184	12-ø11 penetrated, ø17.5 counter bore, depth 10.8	270	12-ø11 penetrated, ø17.5 counter bore, depth 10.8
	CH 228X		12-M10 penetrated		
210	CH 297(G)	240	16-ø14 penetrated, ø20 counter bore, depth 13	350	16-ø14 penetrated, ø20 counter bore, depth 13
	CH 297X		16-M12 penetrated		
350	CH 445(G)	385	24-ø14 penetrated, ø20 counter bore, depth 13	505	24-ø14 penetrated, ø20 counter bore, depth 13
	CH 445X		24-M12 penetrated		

1N ≙ 0.102kgf

15 Cautions when handling Crossed Roller Bearing

1. Insufficient stiffness of the parts to be assembled causes the stress concentrated on contact surface between orbital plane and roller, thereby weakening the performance of the bearing. At the environment with greater moment, housing stiffness and bolt strength shall be thoroughly evaluated.
2. Special synthetic rubber and resin are included in the parts of Crossed Roller Bearing and thus please contact WON ST when using at 80°C or higher temperature
3. Dimensional tolerance shall be in accordance with the requirements to ensure inner & out ring will be tightly contacted with the sides
4. Crossed roller bearing is vulnerable to impact by falling or striking and thus when exposed to impact, check carefully if any functional defect is found despite of no damage is visually found
5. Foreign material once penetrated into the bearing may cause the damage to function and thus protection the bearing from dust or cutting chip shall be provided.
6. Bearing when shipped out is filled with lithium grease and thus it may be used without filling grease. Oil inlet shall be designed to inject oil into inner & outer ring. Lubricant shall be injected at least every 6 months irrespective of working hours.
7. Additive or other lubricant needs to be avoided if possible
8. Please contact WON ST when using at particular environment with high impact or vibration load, clean room, vibration or low / high temperature

Ball Spline

Contents

1	Ball Spline	
	1. Structures & Features.....	112
	2. Transmission of High Torque	112
	3. High load capacity and long life.....	112
	4. Zero Gap	112
2	Selection of Ball Spline	
	1. Overview.....	113
	2. Procedure	113
3	Life Calculation	
	1. Life	114
	2. Rating fatigue life L	114
	3. Static safety factor f_s	116
	4. Basic dynamic load rating C.....	117
	5. Basic static load rating C_0	117
	6. Basic dynamic rating torque T	117
	7. Basic static rating torque T_0 · Basic static rating moment T_M	117
4	Pre-load of Ball Spline	118
5	Accuracy	119
6	Lubrication and contamination prevention of Ball Spline	122
7	Assembly	123
8	Caution in Use	123
9	Compact Ball Spline	
	1. Structures and Features	124
	2. High torque transfer	124
	3. High load capacity and long life.....	124
10	Linear Ball Spline	
	1. Structures and Features	144
	2. High load capacity and long life	144
	3. Precise torque transfer	144
	4. High speed movement, High speed rotation.....	144
	5. Product classification.....	144
	6. Easy for further processing	144

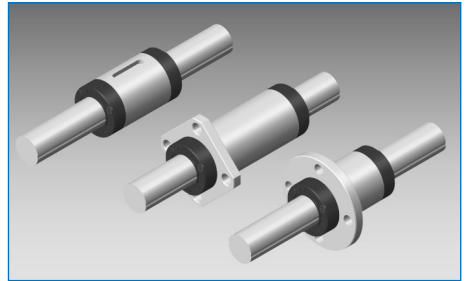

1 Ball Spline

1. Structures & Features

WON Ball Spline is an innovative linear motion system, in that balls accommodated in the spline nut transmit torque while linearly moving on precision-ground raceways on a spline shaft.

Furthermore, one significant difference against the usual ball bush is that a single spline nut can exert preload. As a result of this ability, the Ball Spline is well suited for using under severe service conditions involving vibration and the application of impact loads, and in locations that require highly precise positioning and high-speed operation.

The Ball Spline has two loading ball rows to be arranged so that ball rows in the 2 grooves at 180° to be precisely ground.

2. Transmission of High Torque

The Ball Spline has grooves to be very precisely ground in a round type closely to a ball diameter so that, if torque load is put over spline shaft and spline nut 2 rows are evenly put in the direction of the torque load within the 2 rows with load. The rotation center is automatically determined.

3. High load capacity and long life

The Ball Spline can be made compact, and besides stable safety & longer life should be guaranteed in spite of overload and torsional load.

4. Zero Gap

The Ball Spline minimizes clearance in the rotational direction Gap. Pre-loading on a spline nut can reduce Gap to zero if necessary, there by increasing rigidity.

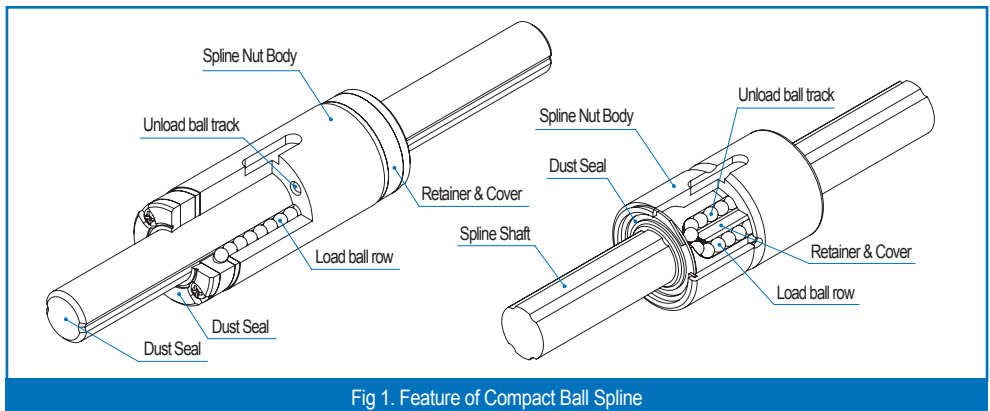

Fig 1. Feature of Compact Ball Spline

Ball Spline	Compact Ball Spline	- 2 rows and 4 points contact type - Simple structure and very compact
	Linear Ball Spline	- 4 rows and 2 points contact type - Angular contact type and high load rating of radial direction and torque direction

2 Selection of Ball Spline

1. Overview

To select Ball Spline, most of all identify detailed requirements and prioritize the requirements to select the Ball Spline suitable for the service conditions.

2. Procedure

- | | |
|--|--|
| 1 Identify service conditions |  equipment, maintenance structure, installation space, assembly status, functional requirements, service conditions |
| 2 Select the type of Ball Spline |  Select the appropriate type by considering motion condition, load level, rigidity, friction, and assembly |
| 3 Select the model number of Ball Spline |  Determine the model number and the quantity of nut by considering the space and load |
| 4 Calculate load |  Calculate the load in vertical and horizontal directions and moment |
| 5 Calculate equivalent load |  Calculate each load applied to the nut and shaft by converting it into equivalent load |
| 6 Calculate mean load |  Calculate each load applied to the nut, shaft and variable load during deceleration by converting them into mean load |
| 7 Calculate static safety factor |  Calculate the static safety factor identified by basic load rating and max. equivalent load and check if it fits for service conditions |
| 8 Calculate life |  Check if it fits for service conditions by calculating load rating and life |
| 9 Review preload & clearance |  Select the pre-load and clearance suitable for service conditions |
| 10 Determine the class of precision |  Determine the class of precision required by Ball Spline while driving or rotating |
| 11 Lubrication, dust proof, surface handling |  Select lubricant suitable for the environment using grease, oil, and special grease lubrication and select seal for dust proof / determine the method of surface handling for rust prevention and low dust raise |
| 12 Complete selection |  Complete the decision of final specifications of Ball Spline |

3 Life Calculation

1. Life

If external load is applied to Ball Spline while driving, fatigue fracture occurs by stress created as load is repeatedly applied to the raceway surface and rolling elements, and flaking-peeling off in scale-like flakes arises. A total driving distance until flaking occurs due to initial fatigue fracture is the life of a linear motion guide.

- Defects may occur in Ball Spline earlier than when flaking normally occurs due to wear or fatigue in the following cases:

- Excess load by the imprecise assembly following a difference in temperature or tolerance
- If Ball Spline is contaminated with foreign substance
- Driving with insufficiency
- Reciprocating motion in a very short distance in the form of vibration or wave during the halt or drive
- Excessive load to Ball Spline
- Deformation of plastic end-plate

2. Rating fatigue life L

Generally Ball Spline does not always have same life even though the products are manufactured in the same way because of the difference in scattering of way material's original fatigue. For this reason, the reference value of life is defined as the rating fatigue life which is a total driving distance that flaking does not occur in 90% of Ball Spline in a group when having them run under the same conditions by grouping multiple Ball Splines with same specifications into a group.

Radial load rating

$$L = \left(\frac{f_H \cdot f_T \cdot f_C}{f_W} \cdot \frac{C}{P_C} \right)^3 \times 50 \text{ km}$$

Torque load rating

$$L = \left(\frac{f_H \cdot f_T \cdot f_C}{f_W} \cdot \frac{T}{P_T} \right)^3 \times 50 \text{ km}$$

$$L_h = \frac{10^3 \cdot L}{2 \times \ell_s \times n_1 \times 60}$$

L : Basic life time (km)

C : Basic dynamic load torque (N)

T : Basic dynamic torque (N · m)

P_C : Calculated load (N)

P_T : Calculated torque (N · m)

f_H : Hardness factor(refer to Pic 4)

f_T : Temperature factor(refer to Pic 5)

f_C : Contact factor(refer to table 1)

f_W : Load factor(refer to table 2)

L_h : Life time (h)

ℓ_s : Stroke length (m)

n₁ : number of round-trip times per minute (min⁻¹)

• Hardness factor (f_H)

To realize the best performance of Ball Spline, the proper hardness and depth should be maintained between the nut contacting a rolling element (ball) and the raceway surface of shaft. WON Ball Spline has HRC58-64 surface hardness, so there is no need to consider hardness factor. But if the hardness is lowered than baseline, Ball Spline's load capacity decreases, so hardness factor needs to be reflected in calculating life.

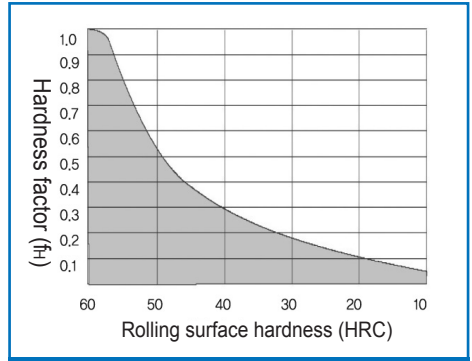

Figure 2. Hardness factor (f_H)

• Temperature factor (f_T)

If high temperature over 100 °C is applied to Ball Spline, temperature factor (f_T) needs to be taken into account when selecting Ball Spline. WON Ball Spline must be used at less than 80 °C. But you have to use it at over 80 °C, please use a high-temp Ball Spline -WON ST's specially customized product.

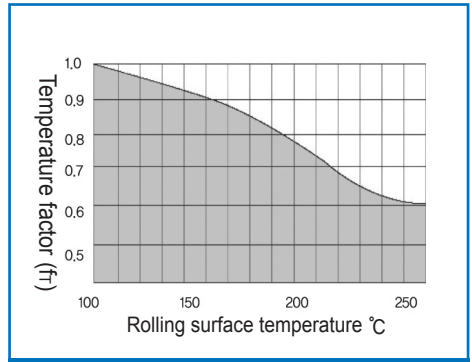

Figure 3. Temperature factor (f_T)

Note) In ambient temperature of over 80, materials for seal, end plate, and support plate should be changed to the specifications for high temperature.

• Contact factor (f_c)

If over two nuts of Ball Spline are closely assembled, since uniform load may not be applied to nuts due to difference among mounting surfaces, you have to multiply basic static load rating (C) and basic dynamic load rating (C_o) by contact factor shown in Table 2.

Table 2. Contact factor (f_c)

No. of nuts contacted	Contact factor (f_c)
2	0.81
3	0.72
4	0.66
5	0.61
Over 6	0.6
Common use	1.0

- Load factor (f_w)

Generally the static load applied to the nut of Ball Spline can be calculated by formula. But the load applied to the nut while running the machine tends to come from vibration or impact. Therefore, you have to consider load factor (f_w) shown in Table 3 for the vibration or impact load during the speedy running of the machine. It can be calculated by dividing the basic dynamic load rating of Ball Spline by load factor (f_w).

Table 3. Load factor (f_w)

External condition	Service conditions	Load factor(f_w)
Low	There is no external vibration or impact due to the smooth running of machine at mild speed.	1.0 ~ 1.3
Moderate	There is moderate external vibration or impact due to the running of machine at low speed.	1.2 ~ 1.5
Big	There is strong vibration or impact due to the running of machine at fast speed.	1.5 ~ 2.0
Very big	There is strong vibration or impact due to the running of machine at very fast speed.	2.0 ~ 4.0

3. Static safety factor f_s

Ball Spline cannot be gotten good movement caused by sectional permanent deformation on a ball and race way if heavy load or impact load act on it. In general, a limit in use depends on the working condition and the requirement of ball spline. In this case, static safety factor is obtained using the following equation and the general values shown in table 4.

$$f_s = \frac{C_o}{P_{ro}} \quad \text{or} \quad f_s = \frac{T_o}{P_{to}}$$

f_s : Static safety factor

C_o : Basic static load rating, (N)

T_o : Static rated toque, (N · m)

P_{ro} : Applied load (N)

P_{to} : Torque (N · m)

Table 4. Static safety factor (f_s)

Used environment	f_s
Vibration & impact	3 ~ 5
High running	2 ~ 4
General movement	1 ~ 3

4. Basic dynamic load rating C

Basic dynamic load rating means a load in regular size of stop diameter direction with the direction which travels at $50 \times 10^3\text{m}$ without material's damage(spalling or flaking) by 90% of fatigue when a group of angular Ball Splines are individually travelled.

Each value of basic dynamic load rating (C) is stated in the catalogue. (Refer to Fig. 4)

5. Basic static load rating C_0

Basic static load rating defines a static load to be given a regular contact stress in the middle of contacting portion both of a rolling body with the maximum load and a track. (Refer to Fig. 4)

6. Basic dynamic rating torque T

Load rating torque means a torque in regular size with the direction which travels at $50 \times 10^3\text{m}$ without material's damage(spalling or flaking) by 90% of fatigue when a group of angular Ball Splines are individually travelled. (Refer to Fig. 5)

7. Basic static rating torque T_0 · Basic static rating moment T_M

Basic static torque and static moment is defined as the constant stress in the middle of contacting portion both of a rolling body and a track under the maximum load when torque and moment (Refer to Fig. 5) are loaded. T_M indicated in the dimension table can endure static moment both of 1 and 2 outer nut to be adhered closely

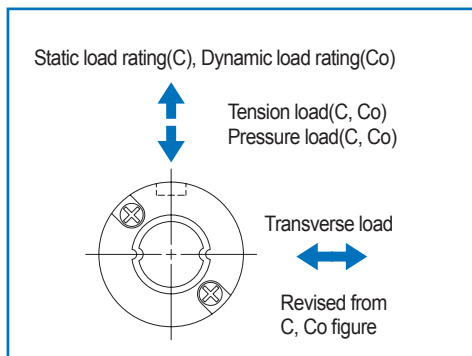

figure 4. Load rating and load effect direction

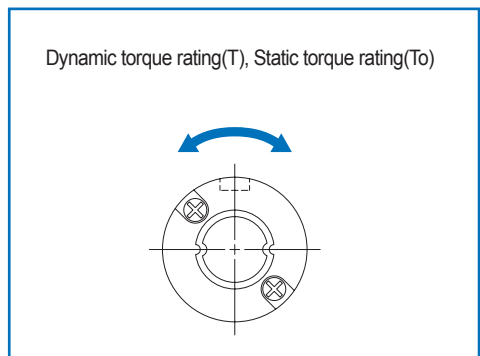

figure 5. Load effect direction of Torque rating

4 Pre-load of Ball Spline

Pre-load

WON's angular Ball Spline can be pre-loaded in case that rigidity and high positioning repeatability in rotational direction are necessary. The average of pre-load is 1/2~1/3 of load, but the amount of pre-load is necessary to be selected with consideration of travel life of Ball Spline in case that vibration load or pulsating load is added, and especially high rigidity is necessary.

WON's angular Ball Spline serves with calculated pre-load based on the load in the circumferential direction. It is indicated according to the method of part number format. We serve the standard pre-load unless there is customer's special requirement/indication. Please inquire to WON in case of the pre-load exceeding light pre-load.

Table 5. Pre-load & Application

Type of pre-load	Symbol	Amount of pre-load	Application
Clearance	CL	0 ⁽¹⁾ ~ +	<ul style="list-style-type: none"> Machines/Equipments for definitely simple operation
Standard	CM	0 ⁽²⁾ ~ -	<ul style="list-style-type: none"> General machines/equipments Machines/Equipments to need small motion resistance
Light preload	CT	0.02C ₀	<ul style="list-style-type: none"> Machines/Equipments to need rigidity Machines/Equipments for big vibration/impact load Machines/Equipments with big moment load or pulsating load

Note(1) Zero or a little of clearance.

Note(2) Zero or a little of pre-load.

Remark) Clearance applies to WSP(F)(K) 4. Light pre-load does not apply to WSP(F)(K) 4

5 Accuracy

WON's angular Ball Spline has the accuracy of KS B 1422(JIS B 1193). It is divided into 3 grades-normal (no symbol), high(H) and Precision(P), and the details is shown in the Table 1~3. The symbol of the grades is marked by the arrangement of the part-numbers. The figures of the tables also include the precision of the case that the shaft-ends are processed(the portions both of supporting and parts mounting in Fig.2) can help even special requirements/inquires for other precision. The measuring method of accuracy is shown in Table 6.

Table 6. The torsion of Ball Spline

Accuracy grade	Torsion (MAX)		
	Normal grade	High(H)	Precision(P)
Tolerance	33 μ m/100mm	13 μ m/100mm	6 μ m/100mm

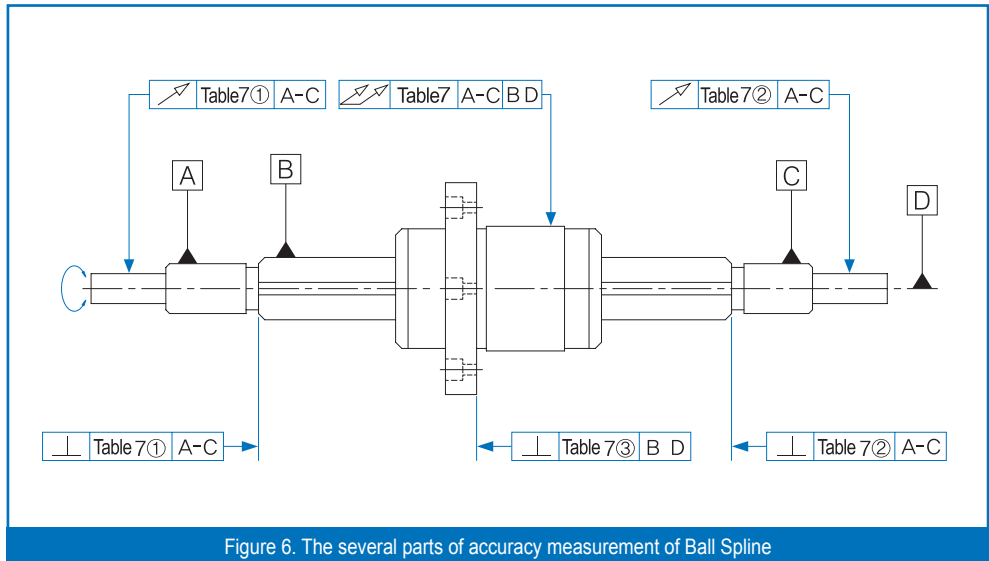

Figure 6. The several parts of accuracy measurement of Ball Spline

Figure 7. The precision of each part on Ball Spline

Unit : μm

Part No.		WSP 4	WSP 5	WSP6	WSP 8	WSP 10	WSP 12	-	WSP 15	WSP 20	WSP 25	WSP 30	WSP 40	
		-			WLS 8	WLS 10	-	WLS 13	WLS 16	WLS 20	WLS 25	WLS 30	WLS 40	
datum plane	① torsion to radial direction on installation place	Normal	33			41		46			53		62	
	High H	14			17		19			22		25		
	Precision P	8			10		12			13		15		
A I C	② vertical angle degree of spline	Normal	22					27			33		39	
	High H	9					6			13		16		
	Precision P	6					8			9		11		
datum plane A I C B D	③ vertical angle degree of flange face to the centerline of spline shaft	Normal	27				33					39		46
	High H	11				13					16		19	
	Precision P	8				9					11		13	

Figure 8. Torsion to radial direction on the center line of Ball Spline

Unit : μm

Shaft (mm)	Over	–	200	315	400	500	630	800	1000	1250
	To	200	315	400	500	630	800	1000	1250	1600
WSP 4 WSP 5 WSP 6 WSP 8	Normal	72	133	185	236	–	–	–	–	–
	High H	46	89	128	163	–	–	–	–	–
	Precision P	26	57	82	108	–	–	–	–	–
WLS 8	Normal	59	83	103	123	151	190	–	–	–
	High H	36	54	68	82	102	130	–	–	–
	Precision P	20	32	41	51	65	85	–	–	–
WSP 10 WSP 12 WLS 10	Normal	56	71	83	95	112	137	170	–	–
	High H	34	45	53	62	75	92	115	–	–
	Precision P	18	25	31	38	46	58	75	–	–
WSP 15 WSP 20 WLS 13 WLS 16 WLS 20	Normal	53	58	70	78	88	103	124	151	–
	High H	32	39	44	50	57	68	83	102	–
	Precision P	18	21	25	29	34	42	52	65	–
WSP 25 WSP 30 WLS 25 WLS 30	Normal	53	58	63	68	74	84	97	114	139
	High H	32	36	39	43	47	54	63	76	93
	Precision P	16	19	21	24	27	32	38	47	–

6 Lubrication and contamination prevention of Ball Spline

Ball Splines are taken care of by all mineral oils and anti-corrosive with affinity. Grease should be recommended for anti-corrosion as it can be lubricated by oil or grease, grease-lubrication additionally gives another sealing effect, and it can be easily adhered inside of Ball Spline. WON's Ball Spline is taken good care of protection against dust using by high quality lithium-soap group of grease with extreme pressure lubricant. Ball Spline with oil-hole to be machined on the nut is used for supplying grease.

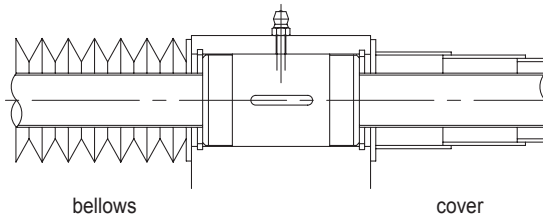

Figure 7. contamination-proof item example

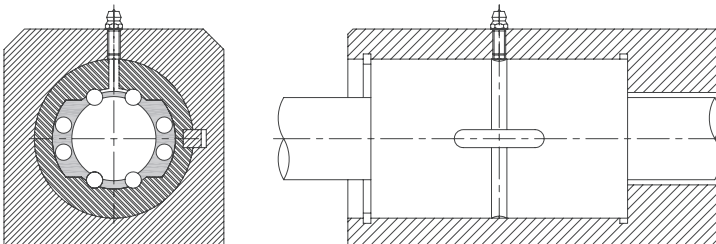

Figure 8. refueling item example

7 Assembly

Fitting

WON's Angular Ball Spline generally has a stop fit (J7) in fitting the nut and the housing. In case that accuracy & rigidity are not so necessary, a clearance fit (H7) is used.

Insertion of the spline nut

When a spline nut is inserted into a housing, it can affect to the operation. Please use a tool for installation and insert it so as not to give any impact to retainer. (fig. 9)

Insertion of the spline shaft

When a spline shaft is inserted into a spline nut, a ball may come out. So that, it should be inserted after exactly setting the location of the track slot of the shaft, the row of balls of the spline nut and the location of the seal.

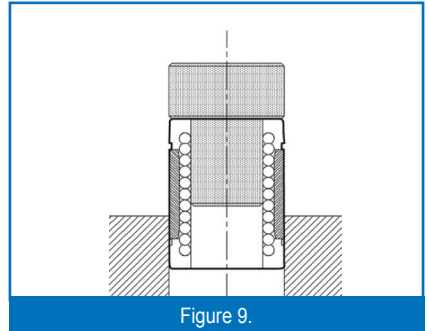

8 Caution in Use

- ① WON's Ball Spline can be used in an environment up to a temperature 120℃, and up to 80℃ for continuous use. Please inquire to WON for the application exceeding the temperature 80℃
- ② WON's Ball Spline has an optimum precision of adjustment at the same portion of both symbols of spline shaft and nut. (refer to fig. 10) When ball spline is installed in a machine, it is necessary to pay attention to keeping steering both nut & ball spline, the arrangement of nut and the steering direction.
- ③ In case that 2 nuts and more are used per shaft and so 2 keys and more is used on the rotational direction of outside fixing, the location of nut key ways should be parallel. For this case, please inquire to WON

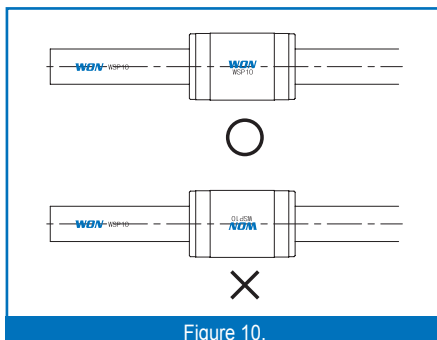

9 Compact Ball Spline

1. Structure and Feature

The structure of WON Ball Spline is composed of nut and shaft.

Balls are in the nut and gothic arch grooves are on the shaft and balls in the nut roll on the grooves as linear movement on the shaft grinded precisely.

One nut withstands radial load, moment load and transfers rotation torque to circumferential direction of shaft. Preload can be adjusted by using the balls assembled between grooves on nut and shaft so this linear movement system could against high vibrating impact load and suitable for high precise position decision, high speed movement and longer life time.

2. High torque transfer

The grooves of spline are on the rolling face of nut and shaft which is ground precisely as gothic arch shape so balls contact with grooves by 4 points. Therefore 2 rows receive same load and transfer turning force under the condition of turning torque on shaft or nut owing to this kind of structure.

3. High load capacity and Long life

Ball Spline has compact structure but the rolling faces of nut and shaft meet ball, the rolling element by face contact. So it can sustain the rated load 10 times more than ball bush in the condition of same diameter and assure longer life time. It's very advantageous for miniaturization of facility and support radial load, moment load and overhang load.

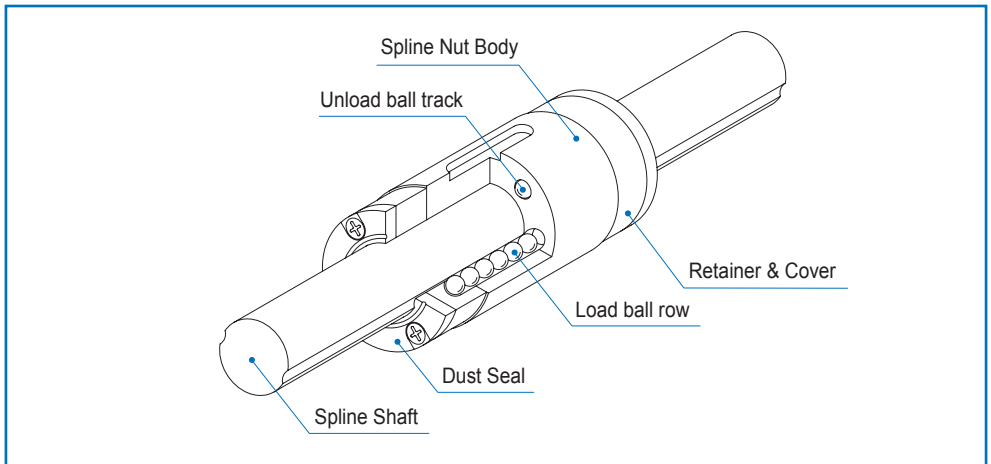

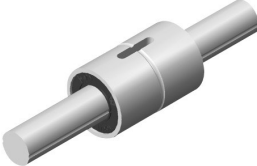
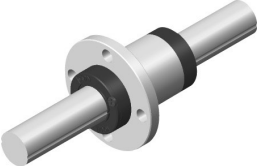
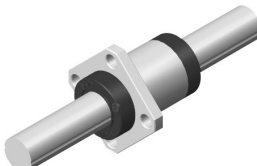
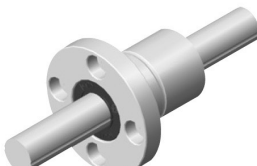

Figure 11. The structure of Compact Ball Spline

Classification	Type	Type & Features	
Round Type	WSP WSPL		Ball Spline nut has a machined key groove so that can fix exactly the position in rotational direction.
	WSPT WSPTO		It has the neat appearance as well as the stable strength according as retainer is inserted into the cover.
	WSPF WSPFL		It has enough strength as it is all-in-one both of flange and the body of Ball Spline nut. Easier installation with round flange.
	WSPK WSPKL		Easier and more compact installation with square flange.
Flange Type	WSPTF WSPTFO		It has enough strength as it is all-in-one both of flange and the body of Ball Spline nut. Easier installation with round flange.

WSP Type

Examples of model number formation

2	WSP	6	S	300	CM	H	/A
1	2	3	4	5	6	7	8

- 1 Q'ty of Nut 2 Part No. 3 Spline-shaft diameter
 4 S:Solid, H:Hollow 5 Spline-shaft overall length
 6 Preload : CT(Tight), CM(Middle), CL(Loose)
 7 Accuracy symbol-Nomal(No symbol), High(H), Precision(P)
 8 SUJ2(No symbol), Stainless steel(/A)

* When the grease nipple is necessary, please ask WON.

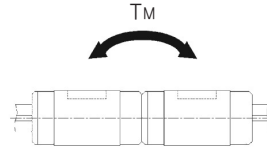
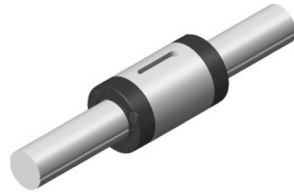

Part No.	Main dimensions											
	Outer Diameter D	Allowable Tolerance	L ₁	L ₂	W	Allowable Tolerance	t	φ	d	Allowable Tolerance	Length L	Max. length
WSP 4 ⁽²⁾	8	0	12	7.9	-	-	1	-	4	-	100 150	200
WSP 5	10	-0.009	18	8.9	2	-	1.2	6	5	0	100 150	200
WSP 6	12	0	21	12.4	2	-	1.2	6	6	-0.012	150 200	300
WSP 8	15	-0.011	25	14.6	2.5	+0.014 0	1.5	8.5	8	0	150 200 250	500
WSP 10	19	0	30	18.2	3	-	1.8	11	10	-0.015	200 300	600
WSP 12	21	-0.013	35	23	3	-	1.8	15	12	0	200 300 400	800
WSP 15	23	0	40	27	3.5	-	2	20	13.6	-0.018	200 300 400	1000
WSP 20	30	0	50	33	4	+0.018 0	2.5	26	18.2	-	300 400 500 600	1000
WSP 25	37	-0.016	60	39.2	5	-	3	29	22.6	0	300 400 500 600 800	-
WSP 30	45	0	70	43	7	-	4	35	27.2	-0.021	400 500 600	1200
WSP 40	60	-0.019	100	70.8	10	+0.022 0	4.5	55	37.2	0	700 1100	-

Note(1) As for the Static load rating moment T_M , the upside figures are for the value for one nut and the downside figure are for the values for 2 nuts to be closely adhered.

(2) There are no seals in WSP 4.

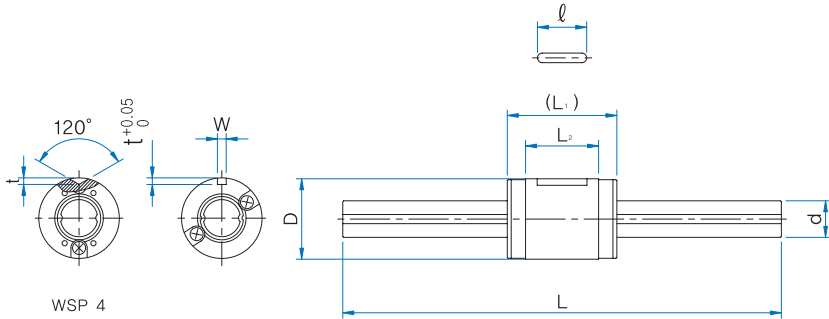

Ball Spline

Unit : mm

Basic load ratings		rating torque		Static load rating moment ⁽¹⁾	Mass		Part No.
C N	Co N	T N·m	To N·m	T _M N·m	Nut g	Shaft g/100mm	
304	382	0.686	0.882	0.49	2.5	9.6	WSP 4 ⁽²⁾
				2.94			
588	637	1.764	1.96	1.078	4.8	14.9	WSP 5
				7.84			
715	853	2.45	3.038	1.764	8.9	19	WSP 6
				11.76			
1176	1372	5.488	6.174	3.234	15.9	39	WSP 8
				21.56			
1862	2156	10.78	12.74	6.958	31.5	60.5	WSP 10
				41.16			
2156	2646	14.7	18.62	10.78	44	87.5	WSP 12
				58.80			
4214	6076	31.36	45.08	27.44	59.5	111	WSP 15
				151.90			
6566	9016	65.66	90.6	49.00	130	202	WSP 20
				287.14			
11196	14294	138.94	177.93	92.76	220	310	WSP 25
				550.78			
15394	19392	230.91	291.88	146.94	430	450	WSP 30
				873.65			
21291	31587	425.83	631.75	363.85	760	808	WSP 40
				1939.22			

1N≒0.102kgf

WSPL Type

Examples of model number formation

2 WSPL 6 - S 300 CM H / A

- 1** Q'ty of Nut **2** Part No. **3** Spline-shaft diameter
4 S:Solid, H:Hollow **5** Spline-shaft overall length
6 Preload : CT(Tight), CM(Middle), CL(Loose)
7 Accuracy symbol-Normal(No symbol), High(H), Precision(P)
8 SUJ2(No symbol), Stainless steel(A)

* When the grease nipple is necessary, please ask WON.

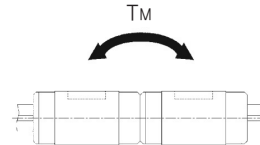

Part No.	Main dimensions											
	Outer Diameter D	Allowable Tolerance	L ₁	L ₂	W	Allowable Tolerance	t	ℓ	d	Allowable Tolerance	Length L	Max. length
WSPL 5	10	0 -0.009	26	17.4	2	+0.014 0	1.2	6	5	0 -0.012	100 150	200
WSPL 6	12	0 -0.011	30	21.4	2		1.2	8	6		150 200	300
WSPL 8	15	0 -0.013	37	26.6	2.5		1.5	8.5	8		150 200 250	500
WSPL 10	19	0 -0.013	47	34.9	3		1.8	11	10	0 -0.015	200 300	600
WSPL 12	21	0 -0.013	54	42	3	+0.018 0	1.8	15	12	0 -0.018	200 300 400	800
WSPL 15	23	0 -0.016	65	52	3.5		2	20	13.6		0 -0.021	200 300 400
WSPL 20	30	0 -0.016	71	54	4	+0.022 0	2.5	26	18.2	0 -0.021	300 400 500 600	1000
WSPL 25	37	0 -0.016	84	63.2	5		3	29	22.6		0 -0.021	300 400 500 600 800
WSPL 30	45	0 -0.016	98	71	7	4	35	27.2	0 -0.021	400 500 600 700 1100		

Note(1) As for the Static load rating moment T_M , the upside figures are for the value for one nut and the downside figure are for the values for 2 nuts to be closely adhered.

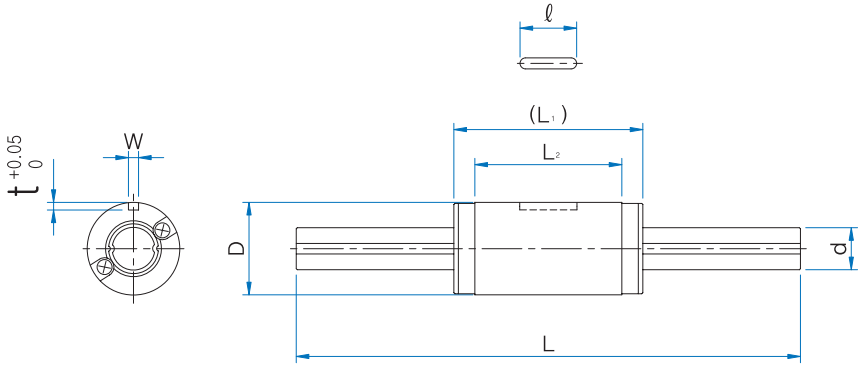

Ball Spline

Unit : mm

Basic load ratings		rating torque		Static load rating moment ¹⁾	Mass		Part No.
C N	Co N	T N·m	To N·m	T _M N·m	Nut g	Shaft g/100mm	
882	1176	2.646	3.528	3.136	7.9	14.9	WSPL 5
				19.60			
1078	1470	3.626	5.194	4.998	14.5	19	WSPL 6
				27.44			
1764	2450	8.33	11.76	9.80	26.5	39	WSPL 8
				56.84			
2842	4018	16.66	23.52	22.54	56.5	60.5	WSPL 10
				115.64			
3234	4802	21.56	33.32	32.34	76.8	87.5	WSPL 12
				156.80			
6370	11564	48.02	86.24	94.08	110	111	WSPL 15
				447.86			
9310	15092	93.10	150.92	127.40	198	202	WSPL 20
				619.36			
15394	23191	192.92	289.88	228.91	336	310	WSPL 25
				1189.52			
21291	31587	319.87	473.81	363.85	634	450	WSPL 30
				1899.24			

1N≒0.102kgf

WSPT Type

Examples of model number formation

2 WSPT 6 - S 300 CM H / A
1 2 3 4 5 6 7 8

- 1** Q'ty of Nut **2** Part No. **3** Spline-shaft diameter
4 S:Solid, H:Hollow **5** Spline-shaft overall length
6 Preload : CT(Tight), CM(Middle), CL(Loose)
7 Accuracy symbol-Nomal(No symbol), High(H), Precision(P)
8 SUJ2(No symbol), Stainless steel(/A)

* When the grease nipple is necessary, please ask WON.

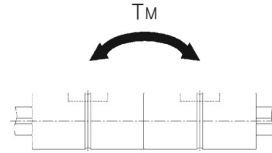
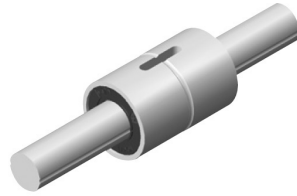

Part No.	Main dimensions										
	Outer Diameter D	Allowable Tolerance	L ₁	W	Allowable Tolerance	t	ℓ	d	Allowable Tolerance	Length L	Max. length
WSPT 4 ⁽²⁾	10	0 -0.009	16	2	+0.014 0	1.2	6	4	0 -0.012	100 150	200
WSPT 5	12	0 -0.011	20	2.5		1.2	8	5		100 150	200
WSPT 6	14		25	2.5		1.2	10.5	6	150 200	300	
WSPT 8	16	25	2.5	1.2		10.5	8	0 -0.015	150 200 250	500	
WSPT 10	21	0 -0.013	33	3	+0.018 0	1.5	13	10	0 -0.018	200 300	600
WSPT 12	24		36	3		1.5	15	12		200 300 400	800
WSPT 15	31	0 -0.016	50	3.5	+0.018 0	2	17.5	13.6	0 -0.021	200 300 400	1000
WSPT 20	35		63	4		2.5	29	18.2		300 400 500 600	1000

Note(1) As for the Static load rating moment T_M , the upside figures are for the value for one nut and the downside figure are for the values for 2 nuts to be closely adhered.

(2) There are no seals in WSP 4.

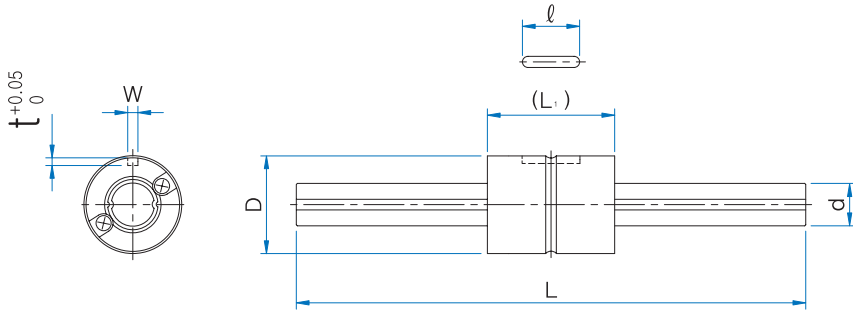

Unit : mm

Basic load ratings		rating torque		Static load rating moment ⁽¹⁾	Mass		Part No.
C N	Co N	T N·m	To N·m	T _M N·m	Nut g	Shaft g/100mm	
441	637	0.588	0.784	0.882	2.5	9.6	WSPT 4 ⁽²⁾
				6.272			
686	882	0.882	1.372	1.47	4.8	14.9	WSPT 5
				11.368			
1176	2156	0.98	1.96	4.9	8.9	19	WSPT 6
				35.57			
1470	2548	1.96	2.94	5.88	15.9	39	WSPT 8
				43.12			
2842	4900	3.92	7.84	15.68	31.5	60.5	WSPT 10
				96.04			
3528	5782	5.88	10.78	19.20	44	87.5	WSPT 12
				135.24			
7056	12642	31.36	34.30	66.84	59.5	111	WSPT 15
				385.14			
10192	17836	56.84	55.86	115.64	130	202	WSPT 20
				686.0			

1N≒0.102kgf

WSPTF Type

Examples of model number formation

2 WSPTF 6 - S 300 CM H / A

1 2 3 4 5 6 7 8

- 1** Q'ty of Nut **2** Part No. **3** Spline-shaft diameter
- 4** S:Solid, H:Hollow **5** Spline-shaft overall length
- 6** Preload : CT(Tight), CM(Middle), CL(Loose)
- 7** Accuracy symbol-Nomal(No symbol), High(H), Precision(P)
- 8** SUJ2(No symbol), Stainless steel(/A)

* When the grease nipple is necessary, please ask WON.

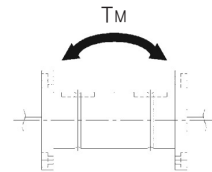
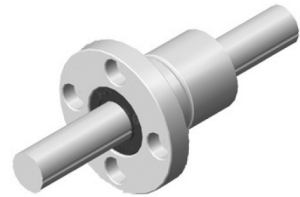

Part No.	Main dimensions										
	Outer Diameter D	Allowable Tolerance	L ₁	D ₂	T	pcd	X x Y x Z	d	Allowable Tolerance	Length L	Max. length
WSPTF 6	14	0 -0.011	25	30	5	22	3.4 x 6.5 x 3.3	6	0 -0.012	150 200	300
WSPTF 8	16	0 -0.013	25	32	5	24	3.4 x 6.5 x 3.3	8		150 200 250	500
WSPTF 10	21	0 -0.016	33	42	6	32	4.5 x 8 x 4.4	10	0 -0.015	200 300	600
WSPTF 12	24		36	44	7	33	4.5 x 8 x 4.4	12		200 300 400	800
WSPTF 15	31	0 -0.018	50	51	7	40	4.5 x 8 x 4.4	13.6	0 -0.015	200 300 400	1000
WSPTF 20	35		63	58	9	45	5.5 x 9.5 x 5.4			18.2	

Note(1) As for the Static load rating moment T_M , the upside figures are for the value for one nut and the downside figure are for the values for 2 nuts to be closely adhered.

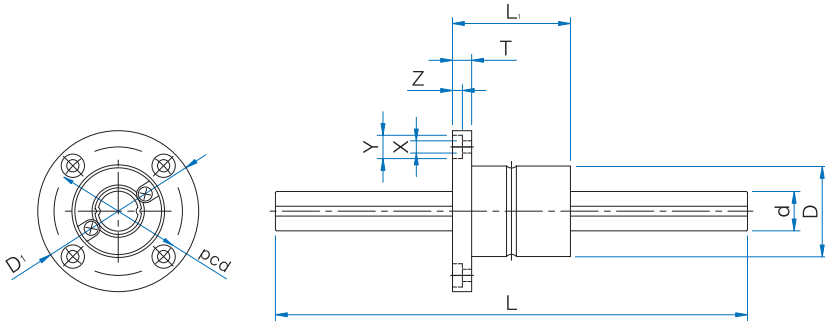

Ball Spline

Unit : mm

Basic load ratings		rating torque		Static load rating moment ¹⁾	Mass		Part No.
C N	Co N	T N·m	To N·m	T _M N·m	Nut g	Shaft g/100mm	
1176	2156	0.98	1.96	4.9	37.2	19	WSPTF 6
				35.57			
1470	2548	1.96	2.94	5.88	39.5	39	WSPTF 8
				43.12			
2842	4900	3.92	7.84	15.68	64.2	60.5	WSPTF 10
				96.04			
3528	5782	5.88	10.78	19.20	124.7	87.5	WSPTF 12
				135.24			
7056	12642	31.36	34.30	66.64	265.7	111	WSPTF 15
				385.14			
10192	17836	56.84	55.86	115.64	392.5	202	WSPTF 20
				686			

1N=0.102kgf

WSPF Type

Examples of model number formation

2	WSPF	6	S	300	CM	H	/A
1	2	3	4	5	6	7	8

- 1** Q'ty of Nut **2** Part No. **3** Spline-shaft diameter
4 S:Solid, H:Hollow **5** Spline-shaft overall length
6 Preload : CT(Tight), CM(Middle), CL(Loose)
7 Accuracy symbol-Nomal(No symbol), High(H), Precision(P)
8 SUJ2(No symbol), Stainless steel(/A)

* When the grease nipple is necessary, please ask WON.

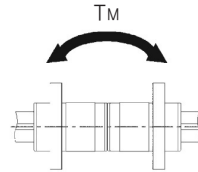
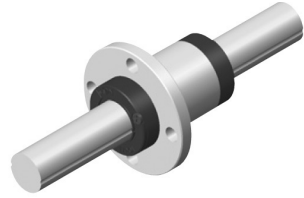

Part No.	Main dimensions											Length L	Max. length
	Outer Diameter D	Allowable Tolerance	L ₁	L ₂	D _i	E	T ₁	pcd	d _i	d	Allowable Tolerance		
WSPF 4 ⁽²⁾	8	0	12	7.9	21	4.6	2.5	15	3.4	4	0 -0.012	100 150	200
WSPF 5	10	-0.009	18	9.4	23	7	2.7	17	3.4	5		100 150	200
WSPF 6	12	0	21	12.4	25	7	2.7	19	3.4	6	0 -0.011	150 200	300
WSPF 8	15	-0.011	25	14.6	28	9	3.8	22	3.4	8		150 200 250	500
WSPF 10	19	0	30	18.2	36	10	4.1	28	4.5	10	0 -0.015	200 300	600
WSPF 12	21	-0.013	35	23	38	10	4	30	4.5	12		200 300 400	800
WSPF 15	23	0	40	27	40	11	4.5	32	4.5	13.6	0 -0.018	200 300 400	1000
WSPF 20	30	-0.016	50	33	46	14	5.5	38	4.5	18.2		300 400 500 600	1000
WSPF 25	37	0	60	39.2	57	17	6.6	47	5.5	22.6	0 -0.021	300 400 500 600 800	1200
WSPF 30	45	-0.019	70	43	65	21	7.5	54	6.6	27.2		400 500 600	
WSPF 40	60	0	100	70.8	93	26.6	12	73	9	37.2	0 -0.025	700 1100	

Note(1) As for the Static load rating moment T_M , the upside figures are for the value for one nut and the downside figure are for the values for 2 nuts to be closely adhered.

(2) There are no seals in WSP 4.

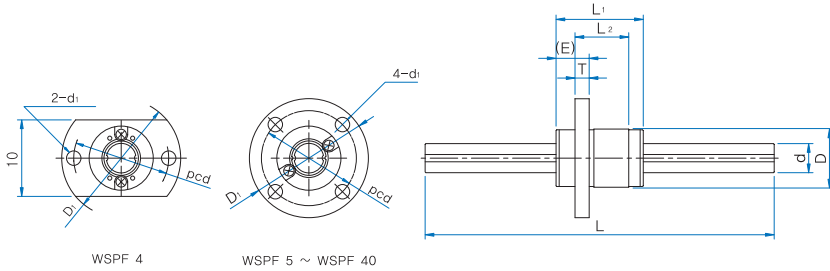

Ball Spline

Unit : mm

Basic load ratings		rating torque		Static load rating moment ⁽¹⁾	Mass		Part No.
C N	Co N	T N·m	To N·m	T _M N·m	Nut g	Shaft g/100mm	
303	382	0.686	0.882	0.49	5.1	9.6	WSPF 4 ⁽²⁾
				2.94			
588	637	1.764	1.96	1.078	8.9	14.9	WSPF 5
				7.84			
715.4	853	2.45	3.038	1.764	13.9	19	WSPF 6
				11.76			
1176	1372	5.488	6.174	3.234	23.5	39	WSPF 8
				21.56			
1862	2156	10.78	12.74	6.958	45	60.5	WSPF 10
				41.16			
2156	2646	14.70	18.62	10.78	59	87.5	WSPF 12
				58.80			
4214	6076	31.36	45.08	27.44	77	111	WSPF 15
				151.90			
6566	9016	65.66	90.16	49.00	150	202	WSPF 20
				287.14			
11196	14294	138.94	177.93	92.76	255	310	WSPF 25
				550.78			
15349	19392	230.91	291.88	146.94	476	450	WSPF 30
				873.65			
21291	31587	425.83	631.75	363.85	962	808	WSPF 40
				1939.22			

⁽¹⁾1N=0.102kgf

WSPFL Type

Examples of model number formation

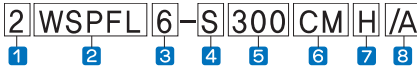

- 1 Q'ty of Nut 2 Part No. 3 Spline-shaft diameter
- 4 S:Solid, H:Hollow 5 Spline-shaft overall length
- 6 Preload : CT(Tight), CM(Middle), CL(Loose)
- 7 Accuracy symbol-Nomal(No symbol), High(H), Precision(P)
- 8 SUJ2(No symbol), Stainless steel(/A)

* When the grease nipple is necessary, please ask WON.

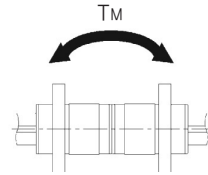
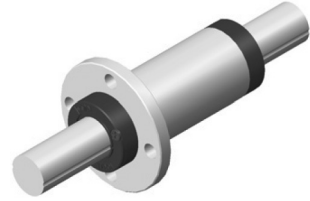

Part No.	Main dimensions											Length L	Max. length
	Outer Diameter D	Allowable Tolerance	L ₁	L ₂	D _i	E	T	pcd	d _i	d	Allowable Tolerance		
WSPFL 5	10	0 -0.009	26	17.4	23	7	2.7	17	3.4	5	0 -0.012	100 150	200
WSPFL 6	12	0 -0.011	30	21.4	25	7	2.7	19	3.4	6		150 200	300
WSPFL 8	15		0 -0.015	37	26.6	28	9	3.8	22	3.4	8	150 200 250	500
WSPFL 10	19	0 -0.013		47	34.9	36	10	4.1	28	4.5	10	150 200 250	600
WSPFL 12	21		0 -0.018	54	42	38	10	4	30	4.5	12	200 300	800
WSPFL 15	23	0 -0.021		65	52	40	11	4.5	32	4.5	13.6	200 300 400	1000
WSPFL 20	30		0 -0.016	71	54	46	14	5.5	38	4.5	18.2	300 400 500 600	1000
WSPFL 25	37	0 -0.021		84	63.2	57	17	6.5	47	5.5	22.6	300 400 500 600 800	1200
WSPFL 30	45		98	71	65	21	7.5	54	6.5	27.2	400 500 600 700 1100		

Note(1) As for the Static load rating moment T_m , the upside figures are for the value for one nut and the downside figure are for the values for 2 nuts to be closely adhered.

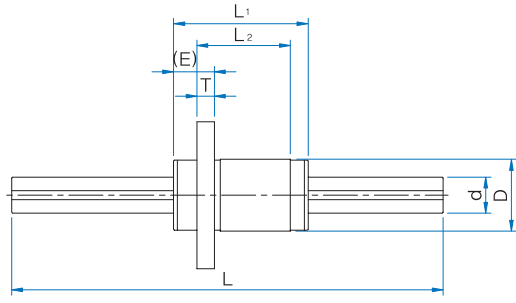
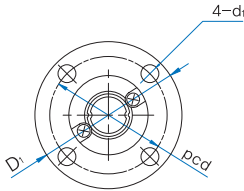

Ball Spline

Unit : mm

Basic load ratings		rating torque		Static load rating moment ⁽¹⁾	Mass		Part No.
C N	Co N	T N·m	To N·m	T _M N·m	Nut g	Shaft g/100mm	
882	1176	2.646	3.528	3.136	12	14.9	WSPFL 5
				19.60			
1078	1470	3.626	5.194	4.998	19.5	19	WSPFL 6
				27.44			
1764	2450	8.33	11.76	9.80	34.1	39	WSPFL 8
				56.84			
2842	4018	16.66	23.52	22.54	70	60.5	WSPFL 10
				115.64			
3234	4802	21.56	33.32	32.34	91.8	87.5	WSPFL 12
				156.80			
6370	11564	48.02	86.24	94.08	127.5	111	WSPFL 15
				447.86			
9310	15092	93.10	150.92	127.40	218	202	WSPFL 20
				619.36			
15394	23191	192.92	289.88	228.91	371	310	WSPFL 25
				1189.52			
21291	31587	319.84	473.81	363.85	680	450	WSPFL 30
				1899.24			

¹1N≒0.102kgf

WSPK Type

Examples of model number formation

2	WSPK	6	S	300	CM	H	/A
1	2	3	4	5	6	7	8

- 1 Q'ty of Nut 2 Part No. 3 Spline-shaft diameter
 4 S:Solid, H:Hollow 5 Spline-shaft overall length
 6 Preload : CT(Tight), CM(Middle), CL(Loose)
 7 Accuracy symbol-Normal(No symbol), High(H), Precision(P)
 8 SUJ2(No symbol), Stainless steel(/A)

* When the grease nipple is necessary, please ask WON.

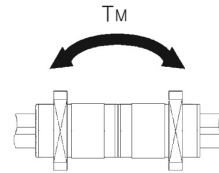
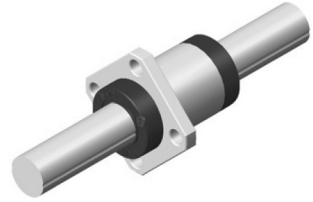

Part No.	Main dimensions												Length L	Max. length
	Outer Diameter D	Allowable Tolerance	L ₁	L ₂	D ₂	B	E	T	pcd	d _i	d	Allowable Tolerance		
WSPK 4 ⁽²⁾	8	0	12	7.9	21	10	4.6	2.5	15	3.4	4	0 -0.012	100 150	200
WSPK 5	10	-0.009	18	9.4	23	18	7	2.7	17	3.4	5		100 150	200
WSPK 6	12	0	21	12.4	25	20	7	2.7	19	3.4	6	0 -0.011	150 200	300
WSPK 8	15	-0.011	25	14.6	28	22	9	3.8	22	3.4	8		150 200 250	500
WSPK 10	19	0	30	18.2	36	28	10	4.1	28	4.5	10	0 -0.015	200 300	600
WSPK 12	21	-0.013	35	23	38	30	10	4	30	4.5	12		200 300 400	800
WSPK 15	23	0	40	27	40	31	11	4.5	32	4.5	13.6	0 -0.018	200 300 400	1000
WSPK 20	30	-0.016	50	33	46	35	14	5.5	38	4.5	18.2		300 400 500 600	1000
WSPK 25	37	0	60	39.2	57	43	17	6.6	47	5.5	22.6	0 -0.021	300 400 500 600 800	1200
WSPK 30	45	-0.019	70	43	65	50	21	7.5	54	6.6	27.2		400 500 600	
WSPK 40	60	0	100	70.8	93	73	26.6	12	73	9	37.2	0 -0.025	700 1100	

Note(1) As for the Static load rating moment T_M , the upside figures are for the value for one nut and the downside figure are for the values for 2 nuts to be closely adhered.

(2) There are no seals in WSP 4.

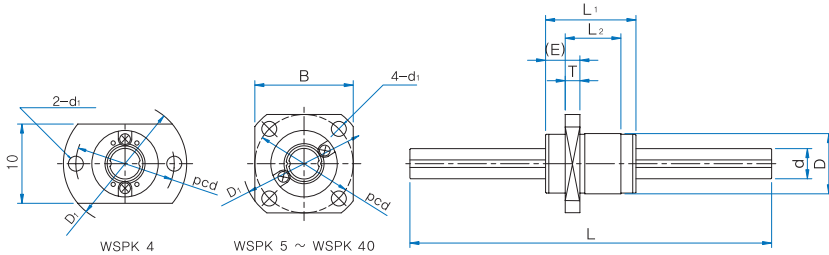

Ball Spline

Unit : mm

Basic load ratings		rating torque		Static load rating moment ⁽¹⁾	Mass		Part No.
C N	Co N	T N·m	To N·m	T _M N·m	Nut g	Shaft g/100mm	
303	382	0.686	0.882	0.49	5.1	9.6	WSPK 4 ⁽²⁾
				2.94			
588	637	1.764	1.96	1.078	8.9	14.9	WSPK 5
				7.84			
715.4	852.6	2.45	3.038	1.764	13.9	19	WSPK 6
				11.76			
1176	1372	5.488	6.174	3.234	23.5	39	WSPK 8
				21.56			
1862	2156	10.78	12.74	6.958	45	60.5	WSPK 10
				41.16			
2156	2646	14.70	18.62	10.78	59	87.5	WSPK 12
				58.80			
4214	6076	31.36	45.08	27.44	77	111	WSPK 15
				151.90			
6566	9016	65.66	90.16	49.00	150	202	WSPK 20
				287.14			
11196	14294	138.94	177.93	92.76	255	310	WSPK 25
				550.78			
15394	19392	230.91	291.88	146.94	476	450	WSPK 30
				873.65			
21291	31587	425.83	631.75	363.85	962	808	WSPK 40
				1939.22			

⁽¹⁾1N=0.102kgf

WSPKL Type

Examples of model number formation

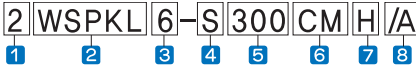

- 1 Q'ty of Nut
- 2 Part No.
- 3 Spline-shaft diameter
- 4 S:Solid, H:Hollow
- 5 Spline-shaft overall length
- 6 Preload : CT(Tight), CM(Middle), CL(Loose)
- 7 Accuracy symbol-Nomal(No symbol), High(H), Precision(P)
- 8 SUJ2(No symbol), Stainless steel(/A)

* When the grease nipple is necessary, please ask WON.

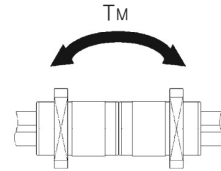
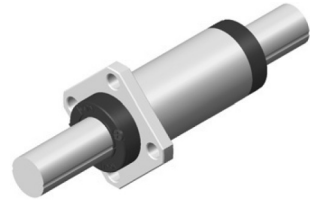

Part No.	Main dimensions												Length L	Max. length
	Outer Diameter D	Allowable Tolerance	L ₁	L ₂	D ₁	E	B	T	pcd	d _i	d	Allowable Tolerance		
WSPKL 5	10	0 -0.009	26	17.4	23	7	18	2.7	17	3.4	5	0 -0.012	100 150	200
WSPKL 6	12	0 -0.011	30	21.4	25	7	20	2.7	19	3.4	6		150 200	300
WSPKL 8	15		0 -0.015	37	26.6	28	9	22	3.8	22	3.4	8	150 200 250	500
WSPKL 10	19	0 -0.013	47	34.9	36	10	28	4.1	28	4.5	10	200 300	600	
WSPKL 12	21		0 -0.018	54	42	38	10	30	4	30	4.5	12	200 300 400	800
WSPKL 15	23	0 -0.016	65	52	40	11	31	4.5	32	4.5	13.6	200 300 400	1000	
WSPKL 20	30		0 -0.021	71	54	46	14	35	5.5	38	4.5	18.2	300 400 500 600	1000
WSPKL 25	37	0 -0.021	84	63.2	57	17	43	6.6	47	5.5	22.6	300 400 500 600 800	1200	
WSPKL 30	45		0 -0.021	98	71	65	21	50	7.5	54	6.6	27.2		400 500 600 700 1100

Note(1) As for the Static load rating moment T_M , the upside figures are for the value for one nut and the downside figure are for the values for 2 nuts to be closely adhered.

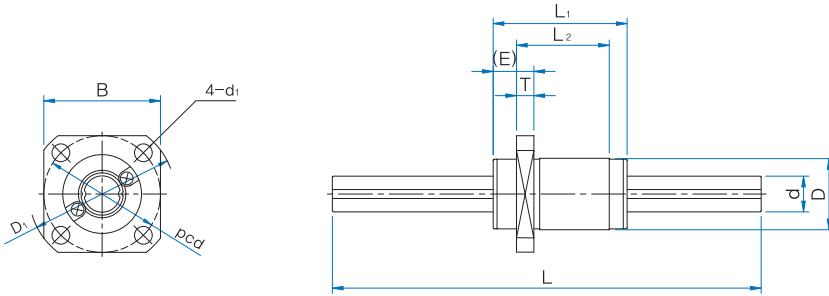

Ball Spline

Unit : mm

Basic load ratings		rating torque		Static load rating moment ⁽¹⁾	Mass		Part No.
C N	Co N	T N·m	To N·m	T _M N·m	Nut g	Shaft g/100mm	
882	1176	2.646	3.528	3.136	12	14.9	WSPKL 5
				19.60			
1078	1470	3.626	5.194	4.998	19.5	19	WSPKL 6
				27.44			
1764	2450	8.33	11.76	9.80	34.1	39	WSPKL 8
				56.84			
2842	4010	16.66	23.52	22.54	70	60.5	WSPKL 10
				115.64			
3234	4802	21.56	33.32	32.34	91.8	87.5	WSPKL 12
				156.80			
6370	11564	48.02	86.24	94.08	127.5	111	WSPKL 15
				447.86			
9310	15092	93.10	150.92	127.40	218	202	WSPKL 20
				619.36			
15394	23191	192.92	289.88	228.91	371	310	WSPKL 25
				1189.52			
21291	31587	319.87	473.81	1899.24	680	450	WSPKL 30

¹N≒0.102kgf

WSPTO Type

Examples of model number formation

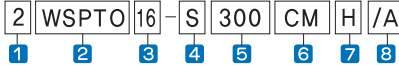

- 1 Q'ty of Nut 2 Part No. 3 Spline-shaft diameter
- 4 S:Solid, H:Hollow 5 Spline-shaft overall length
- 6 Preload : CT(Tight), CM(Middle), CL(Loose)
- 7 Accuracy symbol-Nomal(No symbol), High(H), Precision(P)
- 8 SUJ2(No symbol), Stainless steel(/A)

* When the grease nipple is necessary, please ask WON.

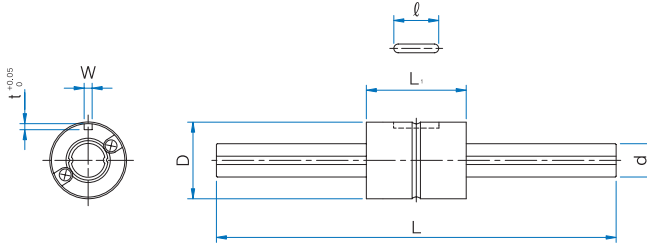
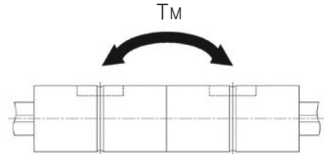
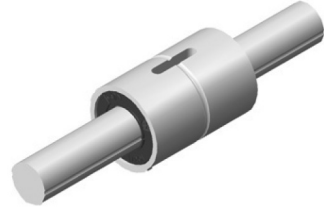

Unit : mm

Part No.	Main dimensions										
	Outer Diameter D	Allowable Tolerance	L ₁	W	Allowable Tolerance	t	l	d	Allowable Tolerance	Length L	Max. length
WSPTO 16	31	0 -0.013	50	3.5	+0.018	2	17.5	16	0 -0.017	200 300 400	1000
WSPTO 20	35	0 -0.016	63	4	0	2.5	29	20	0 -0.020	300 400 500 600	1000

Part No.	Basic load ratings		rating torque		Static load rating moment	Mass	
	C N	C ₀ N	T N · m	T ₀ N · m	T _M N · m	Nut g	Shaft g/100mm
WSPTO 16	7060	12600	31.4	34.3	67.6	165	160
					393		
WSPTO 20	10200	17800	56.9	55.9	118	225	250
					700		

1N≒0.102kgf

Note(1) As for the Static load rating moment T_M, the upside figures are for the value for one nut and the downside figure are for the values for 2 nuts to be closely adhered.

WSPTFO Type

Examples of model number formation

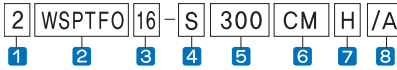

- 1 Q'ty of Nut
- 2 Part No.
- 3 Spline-shaft diameter
- 4 S:Solid, H:Hollow
- 5 Spline-shaft overall length
- 6 Preload : CT(Tight), CM(Middle), CL(Loose)
- 7 Accuracy symbol-Nomal(No symbol), High(H), Precision(P)
- 8 SUJ2(No symbol), Stainless steel(/A)

* When the grease nipple is necessary, please ask WON.

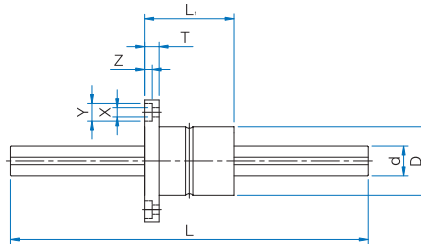
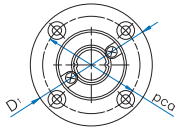
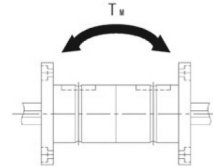
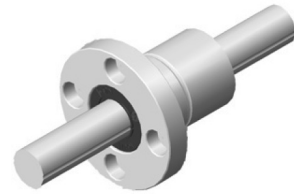

Unit : mm

Part No.	Main dimensions										
	Outer Diameter D	Allowable Tolerance	L ₁	D ₁	T	pcd	X x Y x Z	d	Allowable Tolerance	Length L	Max. length
WSPTFO 16	31	0 -0.013	50	51	7	40	45 x 8 x 4.4	16	0 -0.017	200 300 400	1000
WSPTFO 20	35	0 -0.016	63	58	9	45	5.5 x 9.5 x 5.4	20	0 -0.020	300 400 500 600	1000

Part No.	Basic load ratings		rating torque		Static load rating moment	Mass	
	C N	C ₀ N	T N·m	T ₀ N·m	T _M N·m	Nut g	Shaft g/100mm
WSPTFO 16	7060	12600	31.4	34.3	67.6 393	165	160
WSPTFO 20	10200	17800	56.9	55.9	118 700	225	250

1N≒0.102kgf

Note(1) As for the Static load rating moment T_M, the upside figures are for the value for one nut and the downside figure are for the values for 2 nuts to be closely adhered.

Ball Spline

10 Linear Ball Spline

1. Structure and feature

WON Linear Ball Spline is composed of shaft and nut both has groove as rolling raceway. Retainer, seal, balls are in spline nut which design make it move smoothly.

2. High load capacity and Long life

Raceway is ground as R shape almost similar to the diameter of ball so the contact area is wide and high load capacity and long life could be achieved.

3. Precise torque transfer

The raceway groove of shaft and nut controls balls with optimal contact angle so torque can be transferred by just 1 axis. And we can increase the load capacity or the degree of precise positioning decision by zeroised the gap of rotation direction which conveys preload.

4. High speed movement, High speed rotation

Cylinder is compact and the balance is good so it's good at high speed movement and high speed rotation.

5. Product classification

There are 8 sizes from 8 to 40 and 2 types of nut shape, cylinder type(WLS), flange type(WLSF).

* please contact WON if you need one with other raw material.

6. Easy for further processing

WON Linear Ball Spline has groove raceway for ball rolling on round shaft so it's easy for diverse further processing and popular on varied industrial fields.

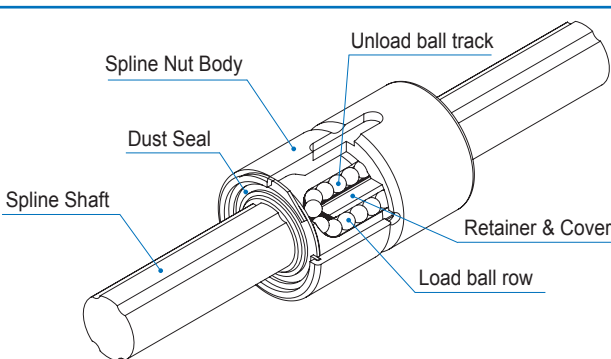
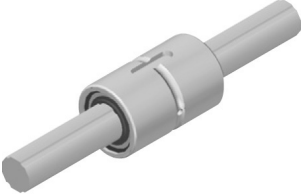
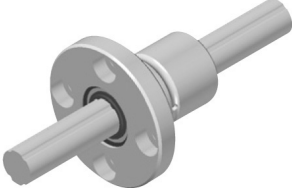

Figure 12. The structure of Linear Ball Spline

Classification	Type	Types & Feature	
Round type	WLS		<p>Ball Spline nut has a machined key groove so that can fix exactly the position in rotational direction.</p>
Flange type	WLSF		<p>It has enough strength as it is all-in-one both of flange and the body of Ball Spline nut. Easier installation with round flange.</p>

※ WON Linear Ball Spline can be selected for use and seal is in all type of nut as a standard component.

WLS Type

Examples of model number formation

2 WLS 8 - S 400 CM H /A
1 2 3 4 5 6 7 8

- 1** Q'ty of Nut **2** Part No. **3** Spline-shaft diameter
- 4** S:Solid, H:Hollow **5** Spline-shaft overall length
- 6** Preload : CT(Tight), CM(Middle), CL(Loose)
- 7** Accuracy symbol-Nomal(No symbol), High(H), Precision(P)
- 8** SUJ2(No symbol), Stainless steel(/A)

* When the grease nipple is necessary, please ask WON.



Part No.	Main dimensions										
	Outer Diameter D	Allowable Tolerance	L ₁	Allowable Tolerance	W	Allowable Tolerance	t	ℓ	O	d	Allowable Tolerance
WLS 8	16	$\begin{matrix} 0 \\ -0.011 \end{matrix}$	25	$\begin{matrix} 0 \\ -0.2 \end{matrix}$	2.5	$\begin{matrix} +0.014 \\ 0 \end{matrix}$	1.2	10.5	1.5	8	0
WLS 10	21	$\begin{matrix} 0 \\ -0.013 \end{matrix}$	33		3		1.5	13	1.5	10	-0.015
WLS 13	24	$\begin{matrix} 0 \\ -0.016 \end{matrix}$	36		3		1.5	15	1.5	13	0
WLS 16	31	$\begin{matrix} 0 \\ -0.016 \end{matrix}$	50		3.5	2	17.5	2	16	-0.018	
WLS 20	35	$\begin{matrix} 0 \\ -0.016 \end{matrix}$	63	$\begin{matrix} 0 \\ -0.3 \end{matrix}$	4	$\begin{matrix} +0.018 \\ 0 \end{matrix}$	2.5	29	2	20	0
WLS 25	42	$\begin{matrix} 0 \\ -0.019 \end{matrix}$	71		4		2.5	36	3	25	
WLS 30	47	$\begin{matrix} 0 \\ -0.019 \end{matrix}$	80		4		2.5	42	3	30	
WLS 40	64	$\begin{matrix} 0 \\ -0.019 \end{matrix}$	100		6		3.5	52	4	40	
											-0.025

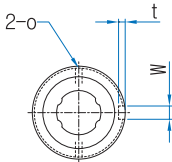

WLS 8-13

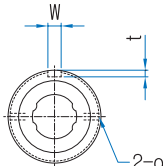

WLS 16-40

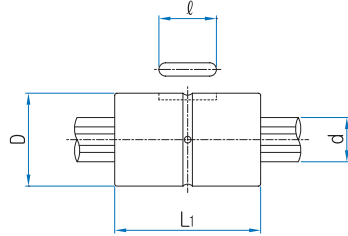

Unit : mm

Basic load ratings		rating torque		Static load rating moment	Mass		Part No.
C N	Co N	T N·m	To N·m	T _M N·m	Nut g	Shaft g/100mm	
1,450	2,870	2.1	3.7	7.4	23	38	WLS 8
2,730	5,070	4.4	8.2	18.0	54	60	WLS 10
2,670	4,890	21	39.2	13.7	70	100	WLS 13
6,120	11,200	60	110	46	150	150	WLS 16
8,900	16,300	105	194	110	220	240	WLS 20
12,800	23,400	189	346	171	330	370	WLS 25
18,600	23,200	307	439	181	360	540	WLS 30
30,800	37,500	647	934	358	950	960	WLS 40

1N=0.102kgf

WLSF Type

Examples of model number formation

2	WLSF	8	S	400	CM	H	/A
1	2	3	4	5	6	7	8

- 1** Q'ty of Nut **2** Part No. **3** Spline-shaft diameter
4 S:Solid, H:Hollow **5** Spline-shaft overall length
6 Preload : CT(Tight), CM(Middle), CL(Loose)
7 Accuracy symbol-Nomal(No symbol), High(H), Precision(P)
8 SUJ2(No symbol), Stainless steel(/A)

* When the grease nipple is necessary, please ask WON.

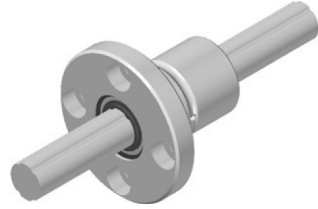

Part No.	Main dimensions											
	Outer Diameter D	Allowable Tolerance	L ₁	Allowable Tolerance	D ₁	T	PCD	X x Y x Z	L ₂	o	d	Allowable Tolerance
WLSF 8	16	0 -0.011	25	0 -0.2	32	5	24	3.4 x 6.5 x 3.3	2.5	2.5	8	0 -0.015
WLSF 10	21	0 -0.013	33		42	6	32	4.5 x 8 x 4.4	3	3	10	
WLSF 13	24		36		43	7	33	4.5 x 8 x 4.4	3	3	13	0 -0.018
WLSF 16	31	0 -0.016	50		50	7	40	4.5 x 8 x 4.4	3.5	3.5	16	
WLSF 20	35		63	58	9	45	5.5 x 9.5 x 5.4	4	4	20	0 -0.021	
WLSF 25	42		71	65	9	52	5.5 x 9.5 x 5.4	4	4	25		
WLSF 30	47		80	75	10	60	6.6 x 11 x 6.5	4	4	30		
WLSF 40	64	0 -0.019	100	0 -0.3	100	14	82	9 x 14 x 8.6	6	6	40	0 -0.025

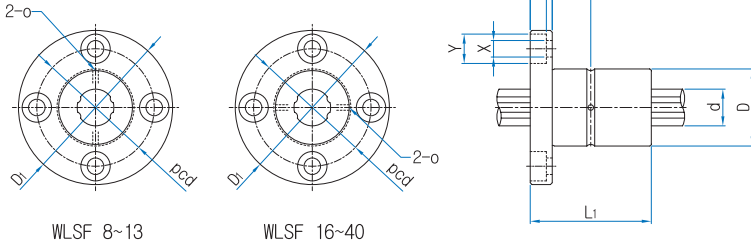

Ball Spline

Unit : mm

Basic load ratings		rating torque		Static load rating moment	Mass		Part No.
C N	Co N	T N · m	To N · m	T _M N · m	Nut g	Shaft g/100mm	
1,450	2,870	2.1	3.7	7.4	42	38	WLSF 8
2,730	5,070	4.4	8.2	18.0	94	60	WLSF 10
2,670	4,890	21	39.2	13.7	100	100	WLSF 13
6,120	11,200	60	110	46	200	150	WLSF 16
8,900	16,300	105	194	110	330	240	WLSF 20
12,800	23,400	189	346	171	450	370	WLSF 25
18,600	23,200	307	439	181	550	540	WLSF 30
18,600	37,500	674	934	358	1,410	960	WLSF 40

1N=0.102kgf



WON
LINEAR MOTION SYSTEM

Cross Roller Guide Way

Contents

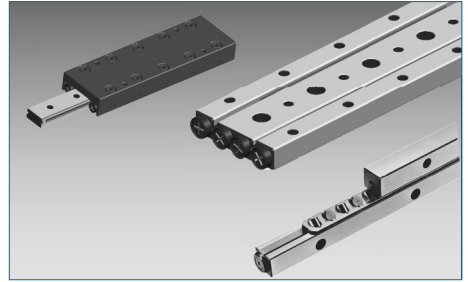

1	Cross Roller Guide Way	
	1. Delicate slide, High rigidity & High accuracy	152
	2. Correspondence in load-direction & Zero-clearance	152
	3. Low noise	152
2	Anti-Creep Cross Roller Guide Way	
	1. Meet the application diversity.....	153
	2. Low Noise and working very smoothly.....	153
	3. Keep high load performance by the sound compatibility of assembly dimensions between old and new one.....	153
3	Types & Features	154
4	Accuracy	155
5	Safe working load & Service life	156
6	Pre-load	158
7	Accuracy of Mounting surface	159
8	Installation Method	159
9	Lubrication & Contamination Prevention	161
10	Caution in Use	162

1 Cross Roller Guide Way

WON's Cross Roller Guide Way consists of the precisely ground raceway and the roller cage. The roller cage, in which precision roller are incorporated at right angle to one another, is fitted into to 90 v-grooved raceway machined on the race rail.

WON's Cross Roller Guide Way is compact linear motion system with high rigidity and high accuracy as a kind of linear motion bearing with low frictional resistance, tight clearance & non-circulation method by big rollers with big contact-areas as a rolling body. Therefore, the Cross Roller Guide Way is being applied to a wide range of equipment, a computer and peripherals, several precision equipments, a tool grinder, automatic lathe machines, electric discharge machines, and slides used in X-ray equipments, to name just a few.

1. Delicate slide, High rigidity & High accuracy

The number of the effective rolling body are many as the rolling body uses precision rollers and it is not circulated (non-circulation). So that, the rigidity is high, the load capacity is big, the fluctuation of frictional resistance is small and there is not almost the difference between the starting frictional resistance and the dynamic frictional resistance.

Therefore, in spite of delicate sliding, the linear motion can keep high precise accuracy.

2. Correspondence in load-direction & Zero-clearance

When two roller guides are installed in parallel, the resulting system can bear loads in all directions perpendicular to the rails. Moreover, since a preload can be applied easily, the system can be a highly rigid, nimble slide mechanism with no clearance.

3. Low noise

In Cross Roller Guide Way, a roller is contacted on the surface of the race rail. So that, the noise is low and rollers have a smooth movement without contact-noise as rollers are supported by a roller cage.

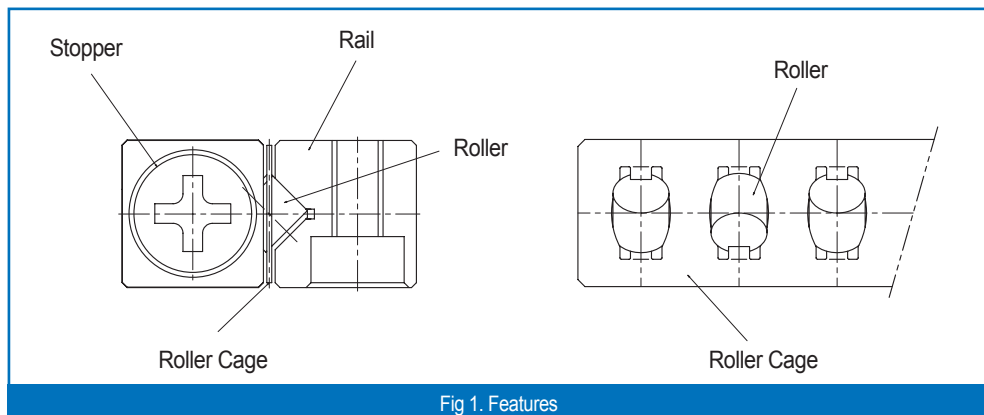
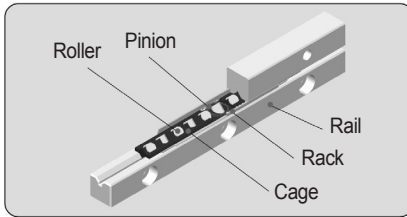

Fig 1. Features

2 Anti-Creep Cross Roller Guide Way

Anti Creep type Cross Roller Guide Way has anti-creep performance with the extremely high precision degree. It is built in a Rack and Pinion gear into the existing WON Cross Roller Guide Way.



WON Anti-Creep Cross Roller Guide Way Construction Plan

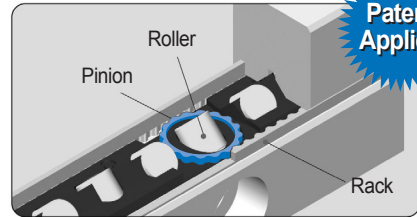

Anti-Creep Detail Plan

1. Meet the application diversity

It is available to meet the ultra accelerated and reduced speed working condition by anti-creeping performance on the race rail so it is conveniently applicable to a vertical axis etc.

2. Low Noise and working very smoothly

Plastic Cage is applied to it instead existing Steel Cage so it causes to minimize a noise between rollers and to work more smoothly and quietly as well.

3. Keep high load performance by the sound compatibility of assembly dimensions between old and new one

Our exclusive technology which the pinion gear wraps the cage roller enables to maintain perfectly compatible with load rating, stroke, assembly measurement as the number of roller is same with general cross roller guide way. 1)

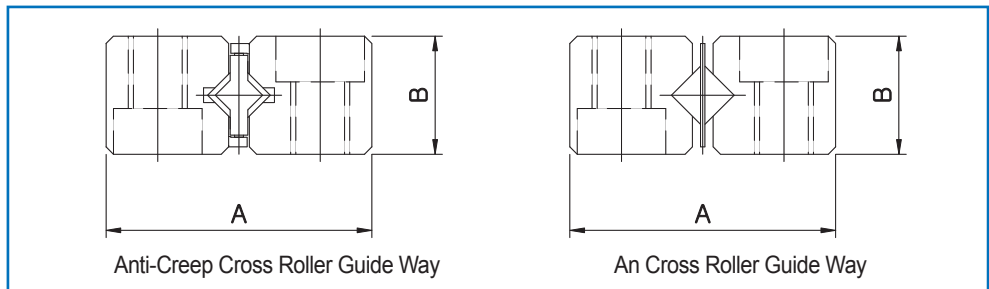

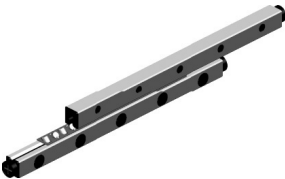





Fig 2. Dimension compatibility

Note 1) The number of roller is not same to No1, No2.

3 Types & Features

Classification	Type		Feature
Guide	Roller Cage		<p>WON's Cross Roller Guide Way consists of the precisely ground raceway and the roller cage. The roller cage, in which precision roller are incorporated at right angle to one another, is fitted into to 90v-grooved raceway machined on the race rail.</p> <p>WRG Guide Way is compact linear motion system with high rigidity and high accuracy as a kind of linear motion bearing with low frictional resistance, tight clearance & non-circulation method by big rollers with big contact areas as a rolling body.</p>
	WRG WRGO WRG-AC		
	WRGW		
Table	WRGT		<p>WRGU Cross roller guide is assembled between precision table and base WRGT is compact and strong linear guide unit.</p>
	WRGU WRGU-AC		

4 Accuracy

There are 3 kind of accuracy grades for WON Cross Roller Guide. Normal, High and Precision.

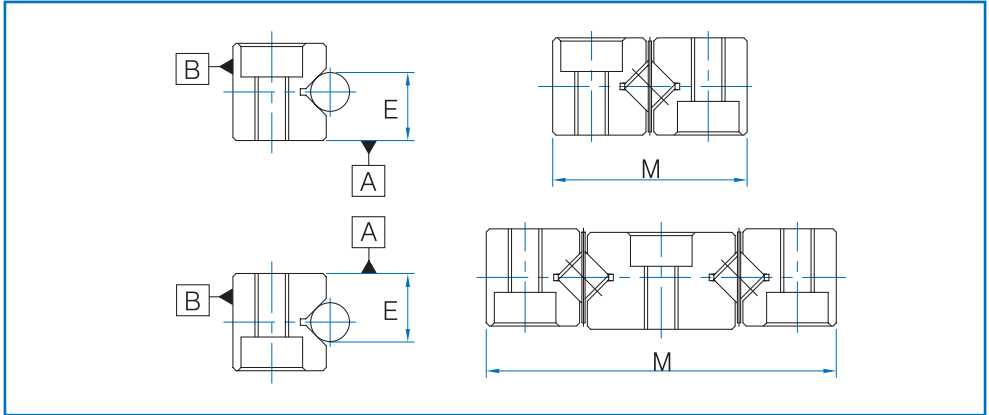

Table1. Accuracy for Race rail.

Accuracy grade	Normal	High	Precision
Symbol	No Symbol	H	P
Items			
Raceway parallelism to surface ㉠ & ㉡	Refer to Table 2		
Dimensional tolerance for height E	±0.02		±0.01
Height E difference among rails	0.02	0.01	0.005
Dimensional tolerance for width M	0 -0.2		0 -0.1

Table2. Raceway Parallelism to surface ㉠ to ㉢ Unit: μm

Rail length	Accuracy grade	Normal (No symbol)	High (H)	Precision (P)
Less than 200		8	4	2
From 200 to 400		10	5	3
From 400 to 600		14	7	4
From 600 to 800		15	9	5
More than 800		20	10	5

Note 1) Difference of Hight 'E' applies to 4 rails installed on the same plane.

Note 2) Please inquire to WON for another dimensions of Cross Roller Guide Way as we do.

5 Safe working load & Service life

The basic load rating C_z , C_{oz} is calculate by the number of running roller(Z) in actual use and basic load rating C , C_o Per running roller.

Basic dynamic load rating

$$C = \left(\frac{Z}{2}\right)^{\frac{3}{4}} \cdot C_z$$

Basic static load rating

$$C_o = \left(\frac{Z}{2}\right) \cdot C_{oz} \quad * \left(\frac{Z}{2}\right) = \text{The number of effective roller (Constant)}$$

Rating life means overall running stroke without any material^oØs damage(spalling or flaking) by 90% of fatigue when a group of LM System is individually travelled at the same conditions. Basic dynamic load rating is calculated by the rating life. Hence comes the life of Cross Roller Guide Way as the below equation.

$$L = \left[\left(\frac{f_H \cdot f_T}{f_W} \right) \cdot \left(\frac{C}{P_C} \right) \right]^{\frac{10}{3}} \cdot 100$$

- L : Basic rating life (km)
- C : Basic dynamic load rating (kN)
- P_c : Calculated load (kN)
- f_H : Hardness factor
- f_T : Temperature factor
- f_W : Load factor

When the stroke & the number of return are indicated, service life is able to be calculated.

$$L_h = \frac{L \times 10^3}{2 \times \ell_s \times n_1 \times 60}$$

- L_h : Service life (hr)
- ℓ_s : Stroke (m)
- n₁ : The number of return (o.p.m.)

Table 3. Hardness factor

Material of race rail	f_H
Carbon steel	1
Stainless steel	0.8

Table 4. Temperature factor

Raceway temperature (°C)	f_T
100	1.00
120	0.97
140	0.93
160	0.88
180	0.82

Table 5. Load factor

Impact & Vibration	Velocity (V)	Measured value (G)	f_w
No Shock vibration from outside	Low speed $V \leq 15\text{m/min}$	$G \leq 0.5$	1.0~1.5
Small Shock vibration from outside	Middle speed $15 < V \leq 60\text{m/min}$	$0.5 \leq G \leq 1.0$	1.0~1.5
Shock vibration from outside	High speed $V > 60\text{m/min}$	$1.0 \leq G \leq 2.0$	1.0~1.5

6 Pre-load

In Cross Roller Guide Way, the application of an excessive preload may cause dents, shorten the service life, and lead to similar problems. The mounted torque of Adjust Bolt should be observed while checking the permissible pre-load levels. (* Adjust Bolt is tightened on the same line with Roller.)

Table 6. Permissible pre-load levels for a row of Roller Cage

Unit : μm

Part No.	R1	R2	R3	R4	R5	R9
Permissible Preload	-2	-3	-4	-5	-7	-10

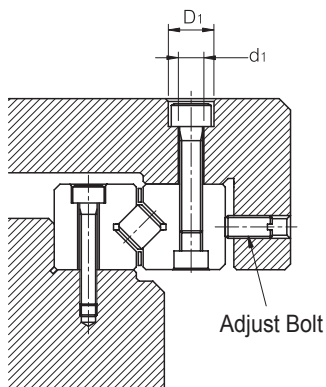
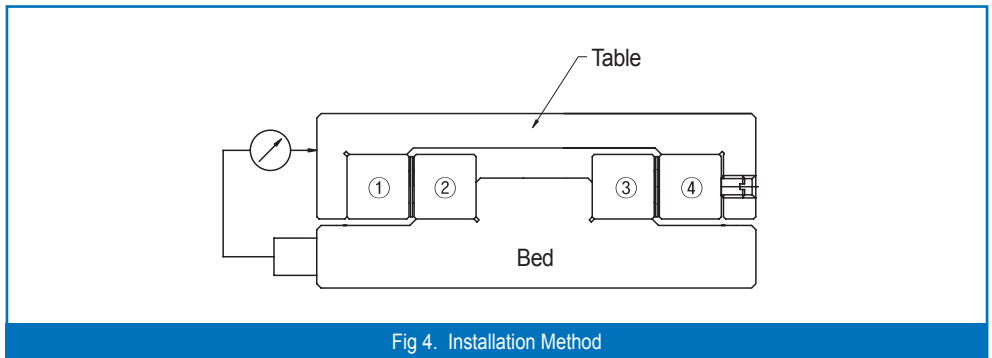

Fig 3. Adjusting pre-load

7 Accuracy of Mounting surface

To ensure high running accuracy, the rail mounting surface should be finished by grinding or a similar method, to a degree of equivalent to or greater than that of the Table. See Table 1

8 Installation Method



- 1) Press rails ①, ② & ③ firmly against the bed and the table, while correctly positioning the mounting surfaces. Firmly tighten the rail-mounting bolts.
- 2) Temporarily fasten rail ④ to the table and make a sure some space for inserting Roller Cage from the rail ends.
- 3) Position a dial gauge as shown in Fig. 4. While gently pressing the table, tighten Adjust Bolt uniformly until there is no slack. Then, attach stoppers to the rail ends, and set the dial gauge to zero.
- 4) Position Roller Cage at the center of rails as shown in Fig.5 Uniformly tighten Adjust Bolt by using a torque wrench or the like, until the dial gauge shows the specified displacement. Then, the displacement showing on the dial gauge is equal to the permissible preload. Fully tighten the mounting bolts within the adjusted area.
- 5) Slide the table from the right and left and complete the installation by mounting the remaining Adjust Bolt(ⓐ, ⓑ in Fig.4) and the Tightened Bolt. at this displacement in the dial pre-load amount. Tighten the mounting bolts at the adjusted positions securely. move the table to the side, finish the installation as tightening the remaining adjustment bolts ⓐ, ⓑ in the same way.

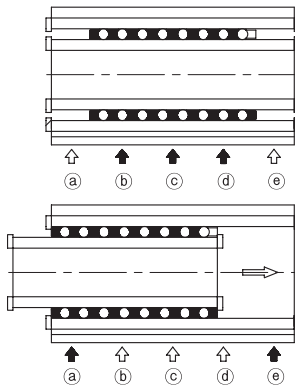
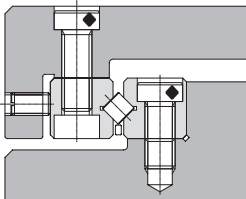
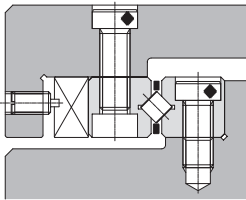

Fig 5. Order to bolting



Normally, the adjustment bolts press on the rail.



When high accuracy & rigidity are required, use a holding bar.

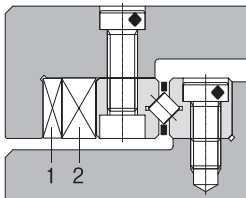

When extremely high accuracy rigidity are required, use tapered GIBS 1 & 2.

Fig.6 Adjust Clearance

9 Lubrication & Contamination Prevention

WON's Cross Roller Guide Way(WRGT, WRGU) may be used as the high quality lithium-soap group of grease cares for it's lubrication. The same kind of grease is recommended for the supplement. We recommend to attach a cover to protect a cross roller guide way as the below Fig.8 in case that a lot of foreign matters or dusts enter into a cross roller guide way and it is used in the kind of environment where is big foreign matter as like cut tips or sand. (Fig.7)

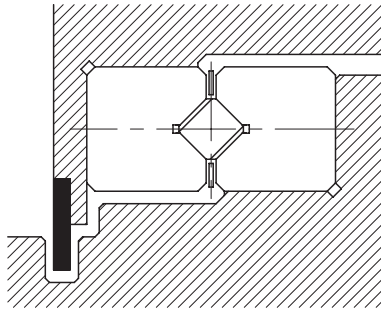

Fig 7.

10 Caution in Use

1. Installation

WON' s Cross Roller Guide Way should observe the uniform pre-load and the mounting torque. When the pre-load is adjusted poorly and the accuracy of the supporting plane is low, the motion accuracy deteriorates. This causes skewing and adversely influences the life.

2. Stopper

Stoppers are provided at the rail ends to prevent cages from falling off. A stopper for the table should be separately installed in outside.

3. One set of use

In WON' s Cross Roller Guide Way, one set of WRG type consists of 4 race rails, WRGW type consists of 3 race rails for one set.

The pair reciprocal tolerance between the individual V-grooves is adjusted within one set and so, to combine the different sets may be a factor to deteriorate the life and the accuracy by reciprocal error. Therefore, installation should be paid attention to these points.

Roller Cage

Examples of model number formation

R	6	-	13Z
1	2		3

1 Part No. 2 Roller Size
3 The number of Roller

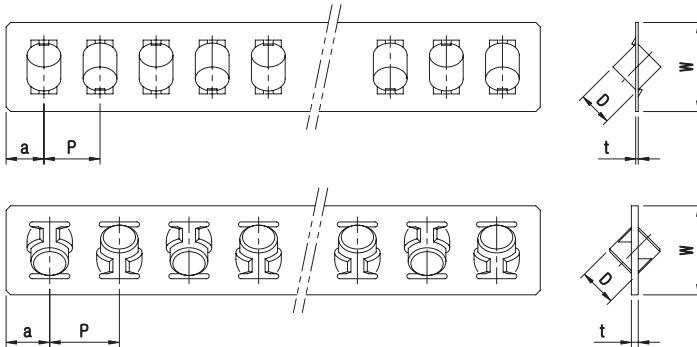

Unit : mm

Part No.	D	t	W	P	a	Cz(kN)	Coz(kN)
R1	1.5	0.2	3.8	2.5	2	0.152	0.153
R2	2	0.25	5	4	2.5	0.276	0.271
R3	3	0.3	7	5	3	0.639	0.611
R4	4	0.3	10.5	7	4.5	1.38	1.35
R6	6	0.6	13.5	10	6	3.78	3.78
R9	9	1.0	19	14	7.5	9.53	9.48

1N ≅ 0.102kgf

Cross Roller Guide Way

WRG Type

Examples of model number formation

WRG	2	-	150	H	-	26Z
1	2		3	4		5

- 1 Part No. 2 Roller Size 3 Length of Race rail
 4 Accuracy : Normal(No symbol), High(H), Precision(P)
 5 The number of Roller

* Please inquire us for your specially required dimensions & applicator

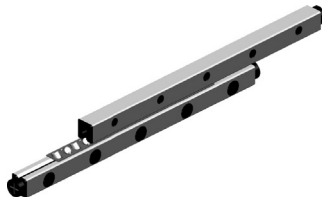

Part No.	Max. Stroke	D	No. of Roller Z	Dimensions					
				L	A	B	C	M×P	N
WRG 1020	12	1.5	5	20	8.5	4	3.8	1×10	5
WRG 1030	22		7	30				2×10	
WRG 1040	27		10	40				3×10	
WRG 1050	32		13	50				4×10	
WRG 1060	37		16	60				5×10	
WRG 1070	42		19	70				6×10	
WRG 1080	52		21	80				7×10	
WRG 2030	18	2	5	30	12	6	5.5	1×15	7.5
WRG 2045	24		8	45				2×15	
WRG 2060	30		11	60				3×15	
WRG 2075	44		13	75				4×15	
WRG 2090	50		16	90				5×15	
WRG 2105	64		18	105				6×15	
WRG 2120	70		21	120				7×15	
WRG 2135	84		23	135				8×15	
WRG 2150	90		26	150				9×15	
WRG 2165	96		29	165				10×15	
WRG 2180	102		32	180				11×15	
WRG 3050	28	3	7	50	18	8	8.3	1×25	12.5
WRG 3075	48		10	75				2×25	
WRG 3100	58		14	100				3×25	
WRG 3125	78		17	125				4×25	
WRG 3150	88		21	150				5×25	
WRG 3175	108		24	175				6×25	
WRG 3200	118		28	200				7×25	
WRG 3225	138		31	225				8×25	
WRG 3250	148		35	250				9×25	
WRG 3275	168		38	275				10×25	
WRG 3300	178		42	300				11×25	
WRG 3325	198		45	325				12×25	
WRG 3350	208		49	350				13×25	

Note 1) 1Set = 4 Race rail + 2 Roller cages + 8 Stoppers.

Note 2) Basic load ratings are based on 1 set.

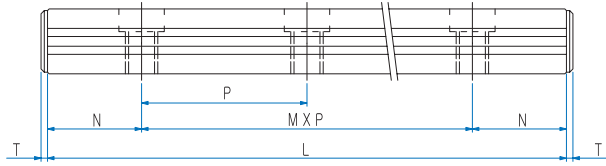
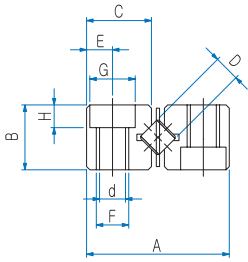

Unit : mm

Dimensions						Basic load ratings		Mass kg/m (Rail/EA)	Part No.	
E	F	d	G	H	T	Dyn. C (kN)	Stat. Co (kN)			
1.8	M2	1.65	3	1.4	1.5	0.46	0.61	0.11	WRG 1020	
						0.63	0.92			WRG 1030
						0.95	1.53			WRG 1040
						1.09	1.84			WRG 1050
						1.37	2.45			WRG 1060
						1.50	2.75			WRG 1070
						1.63	3.06			WRG 1080
2.5	M3	2.55	4.4	2	2	0.46	1.08	0.23	WRG 2030	
						0.81	2.17		WRG 2045	
						0.96	2.71		WRG 2060	
						1.11	3.25		WRG 2075	
						1.39	4.34		WRG 2090	
						1.52	4.88		WRG 2105	
						1.65	5.42		WRG 2120	
						1.78	5.96		WRG 2135	
						2.03	7.05		WRG 2150	
						2.15	7.59		WRG 2165	
2.38	8.67	WRG 2180								
3.5	M4	3.30	6	3.1	2.5	2.71	3.67	0.45	WRG 3050	
						4.06	6.11		WRG 3075	
						5.28	8.55		WRG 3100	
						5.86	9.78		WRG 3125	
						6.98	12.2		WRG 3150	
						8.05	14.7		WRG 3175	
						9.08	17.1		WRG 3200	
						9.58	18.33		WRG 3225	
						10.56	20.8		WRG 3250	
						11.52	23.2		WRG 3275	
						12.45	25.7		WRG 3300	
						12.91	26.9		WRG 3325	
						13.82	29.3		WRG 3350	

1N ≙ 0.102kgf

Cross Roller Guide Way

WRG Type

Examples of model number formation

WRG | 2 | - 300 | H | - 20Z

1 2 3 4 5

- 1 Part No. 2 Roller Size 3 Length of Race rail
 4 Accuracy : Normal(No symbol), High(H), Precision(P)
 5 The number of Roller

* Please inquire us for your specially required dimensions & applicaton

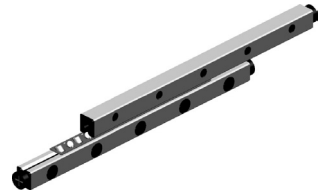

Part No.	Max. Stroke	D	No.of Roller Z	Dimensions					
				L	A	B	C	M×P	N
WRG 4080	58	4	7	80	22	11	10.2	1×40	20
WRG 4120	82		11	120				2×40	
WRG 4160	106		15	160				3×40	
WRG 4200	130		19	200				4×40	
WRG 4240	154		23	240				5×40	
WRG 4280	178		27	280				6×40	
WRG 4320	202		31	320				7×40	
WRG 4360	226		35	360				8×40	
WRG 4400	250		39	400				9×40	
WRG 4440	274		43	440				10×40	
WRG 4480	298	47	480	11×40					
WRG 6100	56	6	7	100	31	15	14.2	1×50	25
WRG 6150	96		10	150				2×50	
WRG 6200	136		13	200				3×50	
WRG 6250	156		17	250				4×50	
WRG 6300	196		20	300				5×50	
WRG 6350	216		24	350				6×50	
WRG 6400	256		27	400				7×50	
WRG 6450	276		31	450				8×50	
WRG 6500	316		34	500				9×50	
WRG 6550	336		38	550				10×50	
WRG 6600	376	41	600	11×50					
WRG 9200	118	9	10	200	44	22	20.2	1×100	50
WRG 9300	178		15	300				2×100	
WRG 9400	238		20	400				3×100	
WRG 9500	298		25	500				4×100	
WRG 9600	358		30	600				5×100	
WRG 9700	418		35	700				6×100	
WRG 9800	478		40	800				7×100	
WRG 9900	538		45	900				8×100	
WRG 91000	598		50	1000				9×100	

Note 1) 1Set = 4 Race rail + 2 Roller cages + 8 Stoppers.

Note 2) Basic load ratings are based on 1 set.

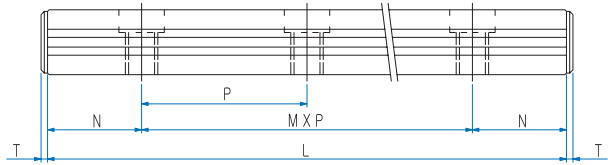
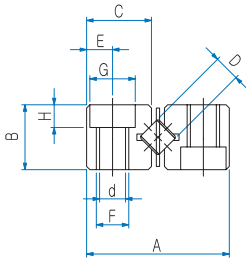

Unit : mm

Dimensions						Basic load ratings		Mass kg/m (Rail/EA)	Part No.
E	F	d	G	H	T	Dyn. C (kN)	Stat. Co (kN)		
4.5	M5	4.3	8	4.2	2.5	5.92	8.10	0.8	WRG 4080
						8.85	13.5		WRG 4120
						11.5	18.9		WRG 4160
						14.0	24.3		WRG 4200
						16.4	29.7		WRG 4240
						18.7	35.1		WRG 4280
						20.88	40.5		WRG 4320
						23.0	45.9		WRG 4360
						25.1	51.3		WRG 4400
						27.1	56.7		WRG 4440
29.1	62.1	WRG 4480							
6	M6	5.2	9.5	5.2	3	16.4	22.7	1.5	WRG 6100
						24.5	37.8		WRG 6150
						28.2	45.4		WRG 6200
						35.4	60.5		WRG 6250
						42.1	75.6		WRG 6300
						48.5	90.7		WRG 6350
						51.7	98.3		WRG 6400
						57.8	113		WRG 6450
						63.7	128		WRG 6500
						69.5	143		WRG 6550
72.3	151	WRG 6600							
9	M8	6.8	10.5	6.2	4	62.3	94.8	3.2	WRG 9200
						81.1	133		WRG 9300
						107	190		WRG 9400
						123	228		WRG 9500
						147	284		WRG 9600
						162	322		WRG 9700
						184	379		WRG 9800
						198	417		WRG 9900
						219	474		WRG 91000

1N ≙ 0.102kgf

Cross Roller Guide Way

WRGO Type

Examples of model number formation

WRGO 6 - 300 H - 20Z

1 2 3 4 5

- 1 Part No. 2 Roller Size 3 Length of Race rail
 4 Accuracy : Normal(No symbol), High(H), Precision(P)
 5 The number of Roller

* Please inquire us for your specially required dimensions & applicaton



Part No.	Max. Stroke	D	No. of Roller Z	Dimensions					
				L	A	B	C	M×P	N
WRGO 6100	56	6	7	100	30	15	14.4	1×50	25
WRGO 6150	96		10	150				2×50	
WRGO 6200	136		13	200				3×50	
WRGO 6250	156		17	250				4×50	
WRGO 6300	196		20	300				5×50	
WRGO 6350	216		24	350				6×50	
WRGO 6400	256		27	400				7×50	
WRGO 6450	276		31	450				8×50	
WRGO 6500	316		34	500				9×50	
WRGO 6550	336		38	550				10×50	
WRGO 6600	376		41	600				11×50	
WRGO 9200	118	9	10	200	40	20	19.2	1×100	50
WRGO 9300	178		15	300				2×100	
WRGO 9400	238		20	400				3×100	
WRGO 9500	298		25	500				4×100	
WRGO 9600	359		30	600				5×100	
WRGO 9700	418		35	700				6×100	
WRGO 9800	478		40	800				7×100	
WRGO 9900	538		45	900				8×100	
WRGO 91000	598		50	1000				9×100	
WRGO 91100	658		55	1100				10×100	
WRGO 91200	718		60	1200				11×100	

Note 1) 1Set = 4 Race rail + 2 Roller cages + 8 Stoppers.

Note 2) Basic load ratings are based on 1 set.

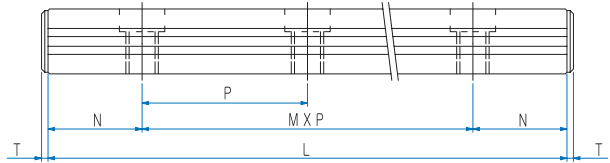
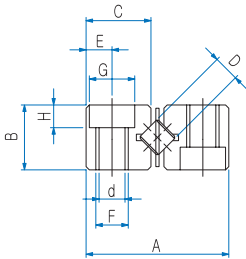

Unit : mm

Dimensions						Basic load ratings		Mass kg/m (Rail/EA)	Part No.
E	F	d	G	H	T	Dyn. C (kN)	Stat. Co (kN)		
6	M6	5.2	9.5	5.2	3	16.4	22.7	1.5	WRGO 6100
						24.5	37.8		WRGO 6150
						28.2	45.4		WRGO 6200
						35.4	60.5		WRGO 6250
						42.1	75.6		WRGO 6300
						48.5	90.7		WRGO 6350
						51.7	98.3		WRGO 6400
						57.8	113		WRGO 6450
						63.7	128		WRGO 6500
						69.5	143		WRGO 6550
72.3	151	WRGO 6600							
8	M8	6.8	10.5	6.2	4	62.3	94.8	3.2	WRGO 9200
						81.1	133		WRGO 9300
						107	190		WRGO 9400
						123	228		WRGO 9500
						147	284		WRGO 9600
						162	322		WRGO 9700
						184	379		WRGO 9800
						198	417		WRGO 9900
						219	474		WRGO 91000
						232	512		WRGO 91100
252	569	WRGO 91200							

1N ≙ 0.102kgf

Cross Roller Guide Way

WRG-AC Type

Examples of model number formation

WRG 3 - 125 AC H - 17Z

1 2 3 4 5 6

- 1 Part No. 2 Roller Size 3 Length of Race rail
 4 Anti-Creep
 5 Accuracy : Normal(No symbol), High(H), Precision(P)
 6 The number of Roller

* Please inquire us for your specially required dimensions & application

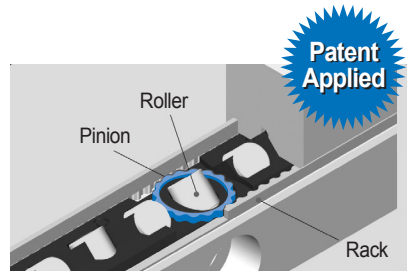

Part No.	Max. Stroke	D	No. of Roller Z	Dimensions					
				L	A	B	C	M×P	N
WRG 2030 AC	18	2	4	30	12	6	5.4	1×15	7.5
WRG 2045 AC	24		7	45				2×15	
WRG 2060 AC	30		10	60				3×15	
WRG 2075 AC	44		12	75				4×15	
WRG 2090 AC	50		15	90				5×15	
WRG 2105 AC	64		17	105				6×15	
WRG 2120 AC	70		20	120				7×15	
WRG 2135 AC	84		22	135				8×15	
WRG 2150 AC	90		25	150				9×15	
WRG 2165 AC	96		28	165				10×15	
WRG 2180 AC	102	31	180	11×15					
WRG 3050 AC	28	3	7	50	18	8	8.3	1×25	12.5
WRG 3075 AC	48		10	75				2×25	
WRG 3100 AC	58		14	100				3×25	
WRG 3125 AC	78		17	125				4×25	
WRG 3150 AC	88		21	150				5×25	
WRG 3175 AC	108		24	175				6×25	
WRG 3200 AC	118		28	200				7×25	
WRG 3225 AC	138		31	225				8×25	
WRG 3250 AC	148		35	250				9×25	
WRG 3275 AC	168		38	275				10×25	
WRG 3300 AC	178		42	300				11×25	
WRG 3325 AC	198		45	325				12×25	
WRG 3350 AC	208		49	350				13×25	
WRG 4080 AC	58		4	7				80	
WRG 4120 AC	82	11		120	2×40				
WRG 4160 AC	106	15		160	3×40				
WRG 4200 AC	130	19		200	4×40				
WRG 4240 AC	154	23		240	5×40				
WRG 4280 AC	178	27		280	6×40				
WRG 4320 AC	202	31		320	7×40				
WRG 4360 AC	226	35		360	8×40				
WRG 4400 AC	250	39		400	9×40				
WRG 4440 AC	274	43		440	10×40				
WRG 4480 AC	298	47		480	11×40				

Note 1) 1Set = 4 Race rail + 2 Roller cages + 8 Stoppers.

2) Basic load ratings are based and mass on 1 set.

3) Needed stopper additional indication is required.

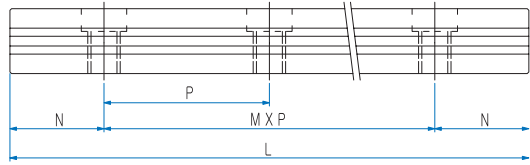
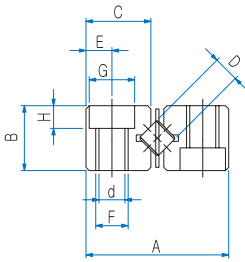

Unit : mm

Dimensions					Basic load ratings		Mass kg/m (Rail/EA)	Part No.	
E	F	d	G	H	Dyn. C (kN)	Stat. Co (kN)			
2.5	M3	2.55	4.4	2	0.62	0.73	0.23	WRG 2030 AC	
					0.86	1.10			WRG 2045 AC
					1.28	1.83			WRG 2060 AC
					1.48	2.20			WRG 2075 AC
					1.67	2.56			WRG 2090 AC
					1.85	2.93			WRG 2105 AC
					2.2	3.66			WRG 2120 AC
					2.37	4.03			WRG 2135 AC
					2.54	4.39			WRG 2150 AC
					2.86	5.13			WRG 2165 AC
					3.02	5.49			WRG 2180 AC
3.5	M4	3.30	6	3.1	2.71	3.67	0.45	WRG 3050 AC	
					4.06	6.11			WRG 3075 AC
					5.28	8.55			WRG 3100 AC
					5.86	9.78			WRG 3125 AC
					6.98	12.2			WRG 3150 AC
					8.05	14.7			WRG 3175 AC
					9.08	17.1			WRG 3200 AC
					9.58	18.33			WRG 3225 AC
					10.56	20.8			WRG 3250 AC
					11.52	23.2			WRG 3275 AC
					12.45	25.7			WRG 3300 AC
12.91	26.9	WRG 3325 AC							
13.82	29.3	WRG 3350 AC							
4.5	M5	4.3	8	4.2	5.92	8.10	0.8	WRG 4080 AC	
					8.85	13.5			WRG 4120 AC
					11.5	18.9			WRG 4160 AC
					14.0	24.3			WRG 4200 AC
					16.4	29.7			WRG 4240 AC
					18.7	35.1			WRG 4280 AC
					20.88	40.5			WRG 4320 AC
					23.0	45.9			WRG 4360 AC
					25.1	51.3			WRG 4400 AC
					27.1	56.7			WRG 4440 AC
					29.1	62.1			WRG 4480 AC

1N ≙ 0.102kgf

Cross Roller Guide Way

WRGW Type

Examples of model number formation

WRGW **2** - **120** **H** - **21Z**

1 2 3 4 5

- 1 Part No. 2 Roller Size 3 Length of Race rail
 4 Accuracy : Normal(No symbol), High(H), Precision(P)
 5 The number of Roller

* Please inquire us for your specially required dimensions & applicaton



Part No.	Max. Stroke	D	No. of Roller Z	Dimensions						
				L	A	t	B ₁	B ₂	C	P ₁
WRGW 1020	12	1.5	5	20	4.5	0.5	17	7.6	3.8	13.4
WRGW 1030	22		7	30						
WRGW 1040	27		10	40						
WRGW 1050	32		13	50						
WRGW 1060	37		16	60						
WRGW 1070	42		19	70						
WRGW 1080	52		21	80						
WRGW 2030	18	2	5	30	6.5	0.5	24	11	5.5	19
WRGW 2045	24		8	45						
WRGW 2060	30		11	60						
WRGW 2075	44		13	75						
WRGW 2090	50		16	90						
WRGW 2105	64		18	105						
WRGW 2120	70		21	120						
WRGW 3050	28	3	7	50	8.5	0.5	36	16.6	8.3	29
WRGW 3075	48		10	75						
WRGW 3100	58		14	100						
WRGW 3125	78		17	125						
WRGW 3150	88		21	150						
WRGW 3175	108		24	175						
WRGW 3200	118		28	200						
WRGW 4080	58	4	7	80	11.5	0.5	44	20.4	10.2	35
WRGW 4120	82		11	120						
WRGW 4160	106		15	160						
WRGW 4200	130		19	200						
WRGW 4240	154		23	240						
WRGW 4280	178		27	280						

Note 1) 1Set = 3 Race rail + 2 Roller cages + 8 Stoppers.

Note 2) Basic load ratings are based on 1 set.

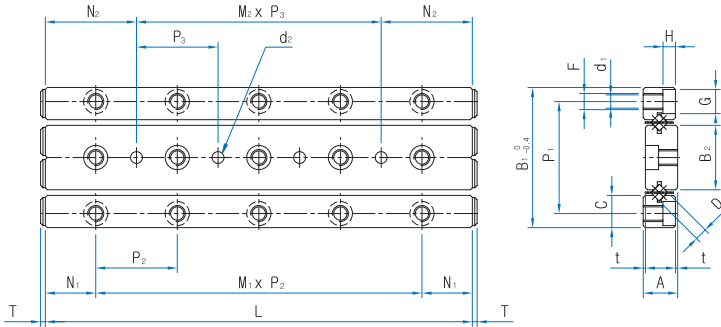

Unit : mm

Dimensions										Basic load ratings		Mass kg/m (Rail/EA)	Part No.
M × P ₂	N ₁	M ₂ × P ₃	N ₂	F	d ₁	G	H	T	d ₂	Dyn. C (kN)	Stat. C ₀ (kN)		
1 × 10		—								0.46	0.61	0.46	WRGW 1020
2 × 10		1 × 10								0.63	0.92		WRGW 1030
3 × 10		2 × 10								0.95	1.53		WRGW 1040
4 × 10	5	3 × 10	10	M2	1.65	3	1.4	1.5	2	1.09	1.84		WRGW 1050
5 × 10		4 × 10								1.37	2.45		WRGW 1060
6 × 10		5 × 10								1.50	2.75		WRGW 1070
7 × 10		6 × 10								1.63	3.06		WRGW 1080
1 × 15		—								0.46	1.08	0.98	WRGW 2030
2 × 15		1 × 15								0.81	2.17		WRGW 2045
3 × 15		2 × 15								0.96	2.71		WRGW 2060
4 × 15	7.5	3 × 15	15	M3	2.55	4.4	2	2	3	1.11	3.25		WRGW 2075
5 × 15		4 × 15								1.39	4.34		WRGW 2090
6 × 15		5 × 15								1.52	4.38		WRGW 2105
7 × 15		6 × 15								1.65	5.42		WRGW 2120
1 × 25		—								2.71	3.67	1.94	WRGW 3050
2 × 25		1 × 25								4.06	6.11		WRGW 3075
3 × 25		2 × 25								5.28	8.55		WRGW 3100
4 × 25	12.5	3 × 25	25	M4	3.3	6	3.1	2.5	4	5.86	9.78		WRGW 3125
5 × 25		4 × 25								6.98	12.2		WRGW 3150
6 × 25		5 × 25								8.05	14.7		WRGW 3175
7 × 25		6 × 25								9.08	17.1		WRGW 3200
1 × 40		—								5.92	8.10	3.36	WRGW 4080
2 × 40		1 × 40								8.85	13.5		WRGW 4120
3 × 40		2 × 40								11.5	18.9		WRGW 4160
4 × 40	20	3 × 40	40	M5	4.3	8	4.2	2.5	5	14.0	24.3		WRGW 4200
5 × 40		4 × 40								16.4	29.7		WRGW 4240
6 × 40		5 × 40								18.7	35.1		WRGW 4280

1N ≙ 0.102kgf

Cross Roller Guide Way

WRGT Type

Examples of model number formation

WRGT	2	055
1	2	3

- 1 Part No. 2 Roller Size 3 Length of Race rail
 4 Hole Type onto the middle rail : Tab(No symbol), Hole(B)

* Please inquire us for your specially required dimensions & applicaton



Part No.	Main Dimensions				Dimensions of the table-surface									
	Max. Stroke	Width W ±0.1	Height M ±0.1	Length L ±0.1	Location of taps onto the table					F _t	n _t ×F _t	D _t	G _t	
					B	F	n×F	G	S					
WRGT 1025	12			25		18	1×18	3.5				1×10		
WRGT 1035	18			35		28	1×28	3.5				2×10		
WRGT 1045	25			45		20	1×20	12.5				3×10		
WRGT 1055	32	20	8	55	14	30	1×30	12.5	M2.6	10		4×10	4.1	7.5
WRGT 1065	40			65		20	2×20	12.5				5×10		
WRGT 1075	45			75		30	1×30	22.5				6×10		
WRGT 1085	50			85		30	2×30	12.5				7×10		
WRGT 2035	18			35		28	1×28	3.5				1×15		
WRGT 2050	30			50		43	1×43	3.5				2×15		
WRGT 2065	40			65		30	1×30	17.5				3×15		
WRGT 2080	50	30	12	80	22	45	1×45	17.5	M3	15		4×15	6	10
WRGT 2095	60			95		30	2×30	17.5				5×15		
WRGT 2110	70			110		45	1×45	32.5				6×15		
WRGT 2125	80			125		45	2×45	17.5				7×15		
WRGT 3055	30			55		40	1×40	7.5				1×25		
WRGT 3080	45			80		65	1×65	7.5				2×25		
WRGT 3105	60			105		50	1×50	27.5				3×25		
WRGT 3130	75	40	16	130	30	75	1×75	27.5	M4	25		4×25	7.5	15
WRGT 3155	90			155		50	2×50	27.5				5×25		
WRGT 3180	105			180		75	1×75	52.5				6×25		
WRGT 3205	130			205		75	2×75	27.5				7×25		

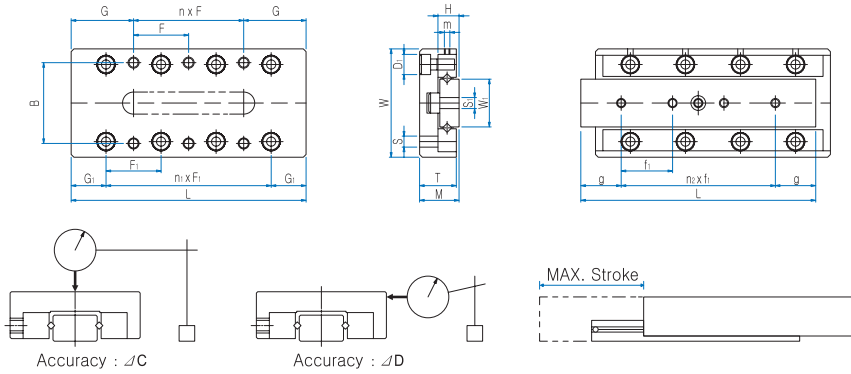

Unit : mm

Dimensions of the side				Dimensions of the bed-surface				Basic load ratings		Accuracy μm		Part No.
T	H	W_1	m	S_1	f_1	$n_2 \times f_1$	g	Dyn. C (kN)	Stat. Co (kN)	ΔC	ΔD	
7.5	4	6.6	M2	M2.6	4.5	2×7.5	5	0.46	0.61	2	4	WRGT 1025
					10.0	2×10	7.5	0.63	0.92	2	4	WRGT 1035
					10.0	3×10	7.5	0.95	1.53	2	5	WRGT 1045
					10.0	4×10	7.5	1.09	1.84	2	5	WRGT 1055
					10.0	5×10	7.5	1.23	2.14	2	5	WRGT 1065
					10.0	6×10	7.5	1.50	2.75	2	5	WRGT 1075
					10.0	7×10	7.5	1.63	3.06	2	5	WRGT 1085
11.5	6	12.0	M2	M3	20.0	1×20	7.5	0.84	1.08	2	4	WRGT 2035
					15.0	2×15	10	1.17	1.63	2	4	WRGT 2050
					15.0	3×15	10	1.46	2.17	2	5	WRGT 2065
					15.0	4×15	10	2.01	3.25	2	5	WRGT 2080
					15.0	5×15	10	2.27	3.79	2	5	WRGT 2095
					15.0	6×15	10	2.52	4.34	2	5	WRGT 2110
15.5	8	16.0	M2	M4	35.0	1×35	10	2.71	3.67	2	5	WRGT 3055
					25.0	2×25	15	4.06	6.11	2	5	WRGT 3080
					25.0	3×25	15	4.68	7.33	3	6	WRGT 3105
					25.0	4×25	15	5.86	9.78	3	6	WRGT 3130
					25.0	5×25	15	6.98	12.2	3	6	WRGT 3155
					25.0	6×25	15	8.05	14.7	3	6	WRGT 3180
					25.0	7×25	15	8.57	15.9	3	6	WRGT 3205

1N \approx 0.102kgf

WRGT-B Type

Examples of model number formation

WRGT	2	055	B
1	2	3	

- 1 Part No. 2 Roller Size 3 Length of Race rail
4 Hole Type onto the middle rail : Tab(No symbol), Hole(B)

* Please inquire us for your specially required dimensions & applicaton

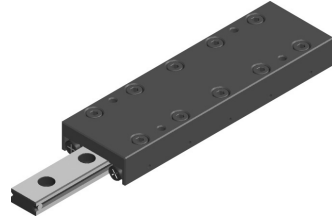

Part No.	Main Dimensions				Dimensions of the table-surface								
	Max. Stroke	Width W ±0.1	Height M ±0.1	Length L	Location of taps onto the table					F _t	n _t ×F _t	D _t	G _t
					B	F	n×F	G	S				
WRGT 1025B	12			25		18	1×18	3.5			1×10		
WRGT 1035B	18			35		28	1×28	3.5			2×10		
WRGT 1045B	25			45		20	1×20	12.5			3×10		
WRGT 1055B	32	20	8	55	14	30	1×30	12.5	M2.6	10	4×10	4.1	7.5
WRGT 1065B	40			65		20	2×20	12.5			5×10		
WRGT 1075B	45			75		30	1×30	22.5			6×10		
WRGT 1085B	50			85		30	2×30	12.5			7×10		
WRGT 2035B	18			35		28	1×28	3.5			1×15		
WRGT 2050B	30			50		43	1×43	3.5			2×15		
WRGT 2065B	40			65		30	1×30	17.5			3×15		
WRGT 2080B	50	30	12	80	22	45	1×45	17.5	M3	15	4×15	6	10
WRGT 2095B	60			95		30	2×30	17.5			5×15		
WRGT 2110B	70			110		45	1×45	32.5			6×15		
WRGT 2125B	80			125		45	2×45	17.5			7×15		
WRGT 3055B	30			55		40	1×40	7.5			1×25		
WRGT 3080B	45			80		65	1×65	7.5			2×25		
WRGT 3105B	60			105		50	1×50	27.5			3×25		
WRGT 3130B	75	40	16	130	30	75	1×75	27.5	M4	25	4×25	7.5	15
WRGT 3155B	90			155		50	2×50	27.5			5×25		
WRGT 3180B	105			180		75	1×75	52.5			6×25		
WRGT 3205B	130			205		75	2×75	27.5			7×25		

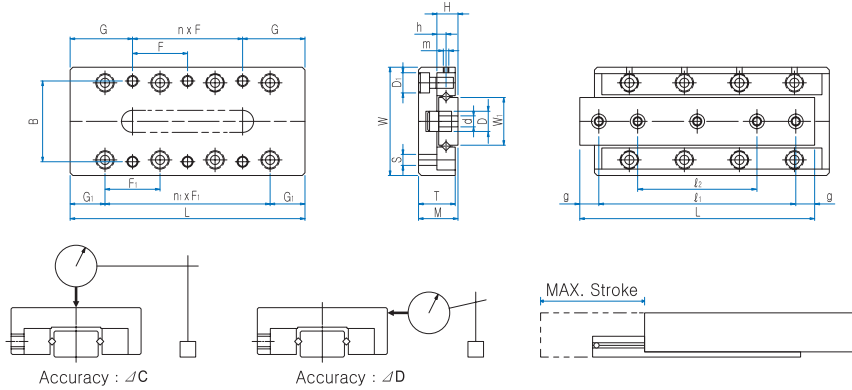

Unit : mm

Cross Roller Guide Way

Dimensions of the side				Dimensions of the bed-surface				Basic load ratings		Accuracy μm		Part No.
T	H	W ₁	m	d×D×h	l ₁	l ₂	g	Dyn. C (kN)	Stat. Co (kN)	ΔC	ΔD	
7.5	4	6.6	M2	2.5×4.1×2.2	18	—	3.5	0.46	0.61	2	4	WRGT 1025B
					25	—	5.0	0.63	0.92	2	4	WRGT 1035B
					38	25	3.5	0.95	1.53	2	5	WRGT 1045B
					48	29	3.5	1.09	1.84	2	5	WRGT 1055B
					55	31	5.0	1.23	2.14	2	5	WRGT 1065B
					65	35	5.0	1.50	2.75	2	5	WRGT 1075B
11.5	6	12.0	M2	3.5×6×3.2	75	40	5.0	1.63	3.06	2	5	WRGT 1085B
					25	—	5.0	0.46	1.08	2	4	WRGT 2035B
					35	—	7.5	0.64	1.63	2	4	WRGT 2050B
					55	33	5.0	0.81	2.17	2	5	WRGT 2065B
					70	40	5.0	1.11	3.25	2	5	WRGT 2080B
					85	45	5.0	1.25	3.79	2	5	WRGT 2095B
15.5	8	16.0	M2	4.5×7.5×4.2	95	50	7.5	1.39	4.34	2	5	WRGT 2110B
					110	55	7.5	1.52	4.88	2	5	WRGT 2125B
					40	—	7.5	2.71	3.67	2	5	WRGT 3055B
					68	43	6.0	4.06	6.11	2	5	WRGT 3080B
					90	55	7.5	4.68	7.33	3	6	WRGT 3105B
					115	65	7.5	5.86	9.78	3	6	WRGT 3130B
15.5	8	16.0	M2	4.5×7.5×4.2	140	95	7.5	6.98	12.2	3	6	WRGT 3155B
					165	85	7.5	8.05	14.7	3	6	WRGT 3180B
					190	90	7.5	8.57	15.9	3	6	WRGT 3205B

1N ≒ 0.102kgf

WRGU Type

Examples of model number formation

WRGU	3	130
1	2	3

1 Part No. 2 Roller Size 3 Length of Race rail

* Please inquire us for your specially required dimensions & applicator



Part No.	Main Dimensions					Dimensions of the table-surface													
	Max. Stroke	Whidth W	Tol-erance	Height M ± 0.1	Length L	Mass (kg)	Location of taps onto the table				Tap's Location onto the side table								
							B	n × F	G	S	n ₁ × F ₁	G ₁	G ₂	b ₁	t ₁	S ₁ × ℓ			
WRGU 1025	12				25	0.08		–				1 × 10		2.5					
WRGU 1035	18				35	0.11		1 × 10				2 × 10		4.5					
WRGU 1045	25				45	0.15		2 × 10				3 × 10		6					
WRGU 1055	32	30	–0.2 –0.4	17	55	0.18	10	3 × 10	12.5	M2		4 × 10	7.5	7.5	12	2.5	M2 × 4		
WRGU 1065	40				65	0.21		4 × 10				5 × 10		8.5					
WRGU 1075	45				75	0.24		5 × 10				6 × 10		11					
WRGU 1085	50				85	0.27		6 × 10				7 × 10		13.5					
WRGU 2035	18				35	0.2		–				1 × 15		3					
WRGU 2050	30				50	0.26		1 × 15				2 × 15		4.5					
WRGU 2065	40				65	0.34		2 × 15				3 × 15		7					
WRGU 2080	50	40	–0.2 –0.4	21	80	0.42	15	3 × 15	17.5	M3		4 × 15	10	9.5	16	3.4	M2 × 4		
WRGU 2095	60				95	0.5		4 × 15				5 × 15		12					
WRGU 2110	70				110	0.58		5 × 15				6 × 15		14.5					
WRGU 2125	80				125	0.66		6 × 15				7 × 15		17					
WRGU 3055	30				55	0.57		–				1 × 25		5.5					
WRGU 3080	45				80	0.8		1 × 25				2 × 25		10.5					
WRGU 3105	60				105	1.03		2 × 25				3 × 25		15.5					
WRGU 3130	75	60	±0.1	28	130	1.26	25	3 × 25	27.5	M4		4 × 25	15	20.5	40	5.5	M3 × 6		
WRGU 3155	90				155	1.49		4 × 25				5 × 25		25.5					
WRGU 3180	105				180	1.72		5 × 25				6 × 25		30.5					
WRGU 3205	130				205	1.95		6 × 25				7 × 25		30.5					

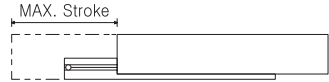
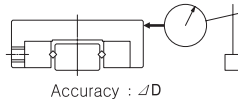
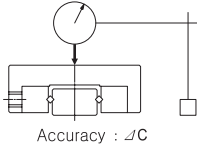
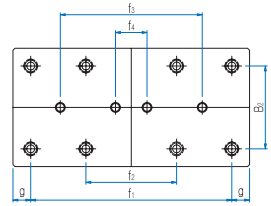
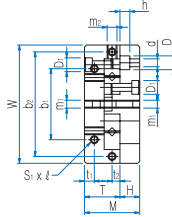
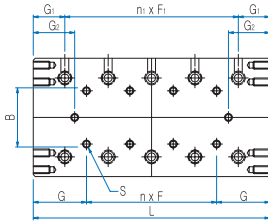

Unit : mm

Cross Roller Guide Way

Dimensions of the side						Dimensions of the bed-surface				Basic load ratings		Accuracy μm		Part No.	
T	H	d×D×h	D ₁	m ₁	m ₂	B ₂	f ₁	f ₂	f ₃	g	Dyn. C (kN)	Stat. Co (kN)	ΔC		ΔD
11	5.5	2.55×4.1×2.5	4.1	M2	M2	22	18	—	—	3.5	0.46	0.61	2	4	WRGU 1025
							28	—	—		0.63	0.92	2	4	WRGU 1035
							38	—	—		0.95	1.53	2	4	WRGU 1045
							48	28	—		1.09	1.84	2	5	WRGU 1055
							58	38	—		1.23	2.14	2	5	WRGU 1065
							68	48	—		1.50	2.75	2	5	WRGU 1075
							78	58	—		1.63	3.06	2	5	WRGU 1085
14	6.4	3.5×6×3.5	6.0	M3	M3	30	25	—	—	5	0.46	1.08	2	4	WRGU 2035
							40	—	—		0.64	1.63	2	4	WRGU 2050
							55	—	—		0.81	2.17	2	5	WRGU 2065
							70	40	—		1.11	3.25	2	5	WRGU 2080
							85	55	—		1.25	3.79	2	5	WRGU 2095
							100	70	—		1.39	4.34	3	6	WRGU 2110
18.5	9	4.5×7.5×5	7.5	M4	M4	40	35	—	—	10	2.71	3.67	2	5	WRGU 3055
							60	—	—		4.06	6.11	2	5	WRGU 3080
							85	—	—		4.68	7.33	3	6	WRGU 3105
							110	—	—		5.86	9.78	3	6	WRGU 3130
							135	—	85		6.98	12.2	3	6	WRGU 3155
							160	—	110		8.05	14.7	3	7	WRGU 3180
185	85	135	8.57	15.9	3	7	WRGU 3205								

1N \approx 0.102kgf

WRGU Type

Examples of model number formation

WRGU	4	125
1	2	3

1 Part No. 2 Roller Size 3 Length of Race rail

* Please inquire us for your specially required dimensions & applicaton



Part No.	Main Dimensions					Dimensions of the table-surface																
	Max. Stroke	Width W ±0.1	Height M ±0.1	Length L	Mass (kg)	Location of taps onto the table				Tap's Location onto the side table												
						B	n×F	G	S	n1×F1	G1	G2	b1	b2	t1	t2	S1×ℓ					
WRGU 4085	50			85	1.5		–			1×40	10.5											
WRGU 4125	75			125	2.3		1×40			2×40	18.0											
WRGU 4165	105	80	35	165	3.1	40	2×40	42.5	M5	3×40	22.5	23.0	55	–	6.5	–						
WRGU 4205	130			3×40	30.5																	
WRGU 4245	155			4×40	38.5																	
WRGU 4285	185			5×40	43.0																	
WRGU 6110	60						110			3.2												
WRGU 6160	95			160	4.6		1×50			2×50	23.5											
WRGU 6210	130			210	60		2×50			3×50	31.0											
WRGU 6260	165	100	45	260	7.4	50	3×50	55	M6	4×50	30.0	38.5	60	92	8	15						
WRGU 6310	200			4×50	46.0																	
WRGU 6360	235			5×50	53.5																	
WRGU 6410	265			6×50	63.5																	
WRGU 9210	130						210			12.0												
WRGU 9310	180			310	17.6		1×100			1×100	52.0											
WRGU 9410	350			410	23.2		2×100			2×100	17.0											
WRGU 9510	450			510	28.8		3×100			3×100	17.0											
WRGU 9610	550	145	60	610	34.4	85	4×100	105	M8	4×100	55.0	17.0	90	135	11	20						
WRGU 9710	650			5×100	17.0																	
WRGU 9810	750			6×100	17.0																	
WRGU 9910	850			7×100	17.0																	
WRGU 91010	950			8×100	17.0																	

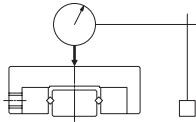
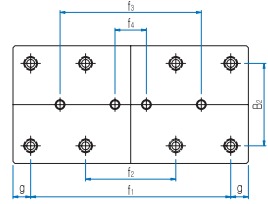
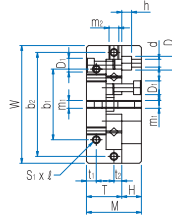
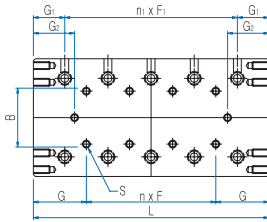

Accuracy : ∠C

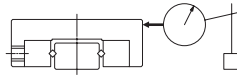

Accuracy : ∠D

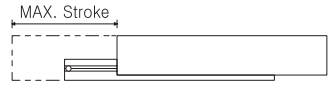

Unit : mm

Dimensions of the side						Dimensions of the bed-surface					Basic load ratings			Accuracy μ m		Part No.
T	H	d×D×h	D ₁	m ₁	m ₂	B ₂	f ₁	f ₂	f ₃	f ₄	g	Dyn. C (kN)	Stat. Co (kN)	∠C	∠D	
24	10.5	5.5×9.5×6	9.5	M4	M4	60	65	-	-	-	10	5.92	8.10	2	5	WRGU 4085
							80	-	-	-	22.5	8.85	13.5	3	6	WRGU 4125
							120	-	-	-	22.5	11.5	18.9	3	7	WRGU 4165
							160	80	-	-	22.5	14.0	24.3	3	7	WRGU 4205
							200	120	-	-	22.5	16.4	29.7	3	7	WRGU 4245
						240	160	-	-	22.5	18.7	35.1	3	7	WRGU 4285	
31	13	7×11×7	11	M5	M5	60	90	-	-	-	10	16.4	22.7	3	6	WRGU 6110
							140	-	-	-	10	20.5	30.2	3	6	WRGU 6160
							190	-	90	-	10	28.2	45.4	3	7	WRGU 6210
							240	-	140	-	10	35.4	60.5	3	7	WRGU 6260
							290	-	190	-	10	38.8	68.0	4	8	WRGU 6310
							340	140	240	-	10	45.4	83.2	4	8	WRGU 6360
						390	190	290	-	10	51.7	98.3	4	8	WRGU 6410	
43	16	9×14×9	14	M8	M6	90	100	-	-	-	55	52.3	75.8	3	7	WRGU 9210
							200	-	-	-	55	81.1	133	3	7	WRGU 9310
							300	-	100	-	55	81.1	133	4	8	WRGU 9410
							400	-	200	-	55	98.7	171	4	8	WRGU 9510
							500	100	300	-	55	115	209	4	9	WRGU 9610
							600	200	400	-	55	131	246	4	9	WRGU 9710
							700	300	500	100	55	139	265	5	10	WRGU 9810
							800	400	600	200	55	155	303	5	10	WRGU 9910
							900	500	700	300	55	169	341	5	10	WRGU 91010

1N \approx 0.102kgf

Cross Roller Guide Way

WRGU-AC Type

Examples of model number formation

WRGU	3	130	AC
1	2	3	4

- 1 Part No. 2 Roller Size 3 Length of Race rail
4 Anti-Creep

* Please inquire us for your specially required dimensions & applicaton



Part No.	Main Dimensions					Dimensions of the table-surface													
	Max. Stroke	Width W ±0.1	Height M ±0.1	Length L	Mass (kg)	Location of taps onto the table				Tap's Location onto the side table									
						B	n × F	G	S	n ₁ × F ₁	G ₁	G ₂	b ₁	t ₁	S ₁ × ℓ				
WRGU 2035 AC	18			35	0.2		–				1 × 15		3						
WRGU 2050 AC	30			50	0.26		1 × 15				2 × 15		4.5						
WRGU 2065 AC	40			65	0.34		2 × 15				3 × 15		7						
WRGU 2080 AC	50	40	21	80	0.42	15	3 × 15	17.5	M3		4 × 15	10	9.5	16	3.4			M2 × 4	
WRGU 2095 AC	60			95	0.5		4 × 15				5 × 15		12						
WRGU 2110 AC	70			110	0.58		5 × 15				6 × 15		14.5						
WRGU 2125 AC	80			125	0.66		6 × 15				7 × 15		17						
WRGU 3055 AC	30			55	0.57		–				1 × 25		5.5						
WRGU 3080 AC	45			80	0.8		1 × 25				2 × 25		10.5						
WRGU 3105 AC	60			105	1.03		2 × 25				3 × 25		15.5						
WRGU 3130 AC	75	60	28	130	1.26	25	3 × 25	27.5	M4		4 × 25	15	20.5	40	5.5			M3 × 6	
WRGU 3155 AC	90			155	1.49		4 × 25				5 × 25		25.5						
WRGU 3180 AC	105			180	1.72		5 × 25				6 × 25		30.5						
WRGU 3205 AC	130			205	1.95		6 × 25				7 × 25		30.5						
WRGU 4085 AC	50			85	1.5		–				1 × 40		10.5						
WRGU 4125 AC	75			125	2.3		1 × 40				2 × 40		18.0						
WRGU 4165 AC	105			165	3.1		2 × 40				3 × 40		23.0						
WRGU 4205 AC	130	80	35	205	3.8	40	3 × 40	42.5	M5		4 × 40	22.5	30.5	55	6.5			M3 × 6	
WRGU 4245 AC	155			245	4.6		4 × 40				5 × 40		38.5						
WRGU 4285 AC	185			485	5.3		5 × 40 ^a				6 × 40		43.0						

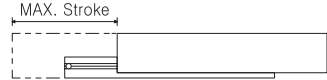
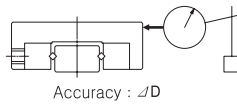
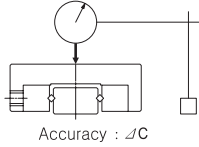
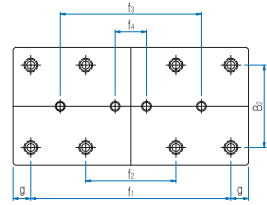
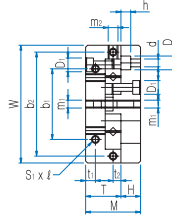
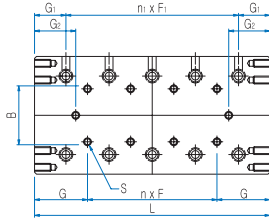

Unit : mm

Cross Roller Guide Way

Dimensions of the side						Dimensions of the bed-surface					Basic load ratings		Accuracy μm		Part No.	
T	H	d×D×h	D ₁	m ₁	m ₂	B ₂	f ₁	f ₂	f ₃	g	Dyn. C (kN)	Stat. Co (kN)	ΔC	ΔD		
14	6.4	3.5×6×3.5	6.0	M3	M3	30	25	-	-	5	0.46	1.08	2	4	WRGU 2035 AC	
							40	-	-		0.64	1.63	2	4	WRGU 2050 AC	
							55	-	-		0.81	2.17	2	5	WRGU 2065 AC	
							70	40	-		1.11	3.25	2	5	WRGU 2080 AC	
							85	55	-		1.25	3.79	2	5	WRGU 2095 AC	
							100	70	-		1.39	4.34	3	6	WRGU 2110 AC	
18.5	9	4.5×7.5×5	7.5	M4	M4	40	35	-	-	10	2.71	3.67	2	5	WRGU 3055 AC	
							60	-	-		4.06	6.11	2	5	WRGU 3080 AC	
							85	-	-		4.68	7.33	3	6	WRGU 3105 AC	
							110	-	-		5.86	9.78	3	6	WRGU 3130 AC	
							135	-	85		6.98	12.2	3	6	WRGU 3155 AC	
							160	-	110		8.05	14.7	3	7	WRGU 3180 AC	
24	10.5	5.5×9.5×6	9.5	M4	M4	60	65	-	-	10	5.92	8.10	2	5	WRGU 4085 AC	
							80	-	-		8.85	13.5	3	6	WRGU 4125 AC	
							120	-	-		22.5	11.5	18.9	3	7	WRGU 4165 AC
							160	80	-		22.5	14.0	24.3	3	7	WRGU 4205 AC
							200	120	-		22.5	16.4	29.7	3	7	WRGU 4245 AC
							240	160	-		22.5	18.7	35.1	3	7	WRGU 4285 AC

1N ≙ 0.102kgf



WON
LINEAR MOTION SYSTEM

Super Ball Bushing

Contents

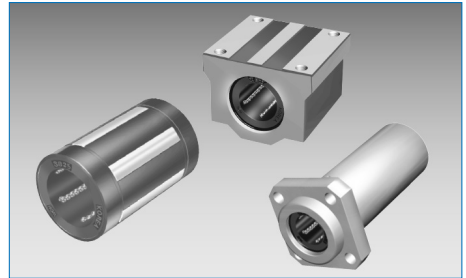

1	Super Ball Bushing	
1.	27 Times longer Travel life (3 Times Higher Load Capacity).....	186
2.	0.5° Self-Aligning	186
3.	Ease of Replacement.....	186
4.	High speed and Fast acceleration.....	186
5.	Ease of Adjusting the radial clearance.....	187
6.	Installation cost reduction	187
7.	Smooth Running	187
8.	Environmental Temperature	187
2	Super Ball Bushing Type	
1.	Asian Standard.....	188
2.	European Standard.....	189
2.	Inch Standard	189
3	Life Span	
1.	Basic Dynamic Load Rating (C).....	190
2.	Hardness factor(f_H)	190
3.	Temperature factor(f_T)	191
4.	Load direction factor(f_D)	191
5.	Basic Static Load Rating(C_0)	191
6.	Housing and Shaft tolerance.....	192
4	Assembly	193

1 Super Ball Bushing

WON have begun home production of Super Ball Bushing at the first time in Korea. Super Ball Bushing for use in heavy load and self-aligning has features as follows.

1. 27 Times longer Travel life (3 Times Higher Load Capacity)

WON Super Ball Bushing affords the designer 27 times longer travel life than conventional ball bushing with the same as-installed dimensions due to the high running speed and 3 times higher dynamic load capacity.

WON Super Ball Bushing consists of hardened steel segmental load bearing plates with precisely ground ball tracks to be designed a little bigger than the ball diameters for unbeaten smooth running and high load. As 0.5° Self-Aligning feature provides uniform load distribution over the entire row of balls and therefore prevents life shortening by partial concentrated pressure.

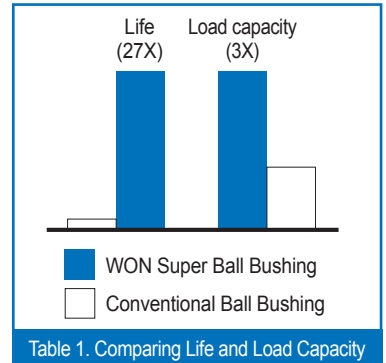

2. 0.5° Self-Aligning

WON Super Ball Bushing automatically compensates for 0.5° Self-Aligning in the axial direction. The outer surface of the steel load bearing plates is designed with the curved surface. This self-aligning feature allows Super Ball Bushing to absorb misalignment caused by inaccuracies between ball bush and shaft so that uniformly distributes load over the entire row of balls. Besides this feature provides smooth entry and exit of the balls into and out of the load carrying area. (The Self-Aligning feature requires two Super Ball Bushings to be mounted on at least one of two shafts of the assembly.)

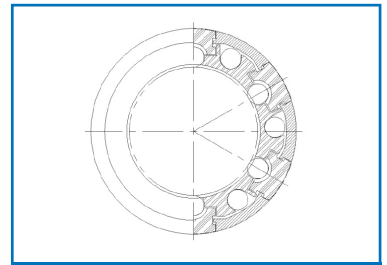

Fig 1. The cross-section of Super Ball Bushing

3. Ease of Replacement

WON Super Ball Bushing is completely interchangeable because of its standard dimensions and strict precision control; SB(JIS standard) for Asian market service and SBE(ISO standard) for Europe market service.

4. High speed and Fast acceleration

WON Super Ball Bushing guarantees velocity 3m/sec and acceleration 150m/sec

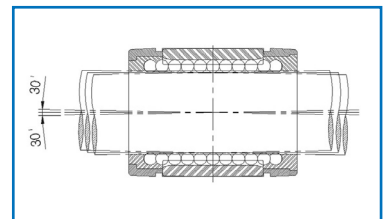

Fig 2. 0.5° of Self-Alignment

5. Ease of Adjusting the radial clearance

When WON Super Ball Bushing is installed into a housing for adjustable clearance, its bearing plates in the radial direction makes the radial clearance to be easily adjusted for precise and strict running.

- Adjusting the Zero clearance

After Super Ball Bushing is installed into a housing for adjustable clearance, the radial clearance must be reduced by means of an adjusting screw in the bushing housing until a slight resistance is felt when the shaft is turned.

In application subject to vibration, the adjusting screw should be suitably secured against working loose once the desired clearance has been established.

- Pre-load

If pre-load is required, we recommend that zero clearance should be established as described above using a dummy shaft whose diameter is smaller by the amount of the desired pre-load(μ) than the actual guide shaft diameter(d) on which the linear bushing is to run.

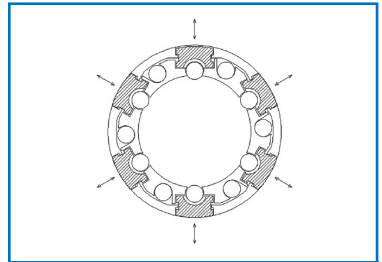

Fig 3. Radial Clearance Adjustment

6. Installation cost reduction

WON Super Ball Bushing provides the reduction both the installation time and cost by the Self-Aligning feature against errors to be caused by inaccurate machining, mounting errors or shaft deflection.

7. Smooth Running

Self-Aligning feature makes easy entry of the balls into the load carrying area. As the bushing and the retainer are made of light and durability of abrasion polyamide, the inertia force and the noise are small. Therefore the friction factor of unsealed WON Super Ball Bushing using oil as a lubrication up to 0.001.

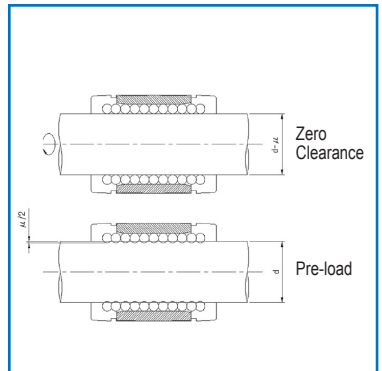

Fig 4. Zero Clearance & Pre-load

8. Environmental Temperature

Use at the higher temperature than 100°C reduces the traveling life. (See Temperature factor of the page A-4.)

2 Super Ball Bushing Type

1. Asian Standard



SB Bearing



SBO Bearing

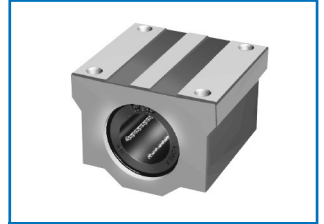

SH Block

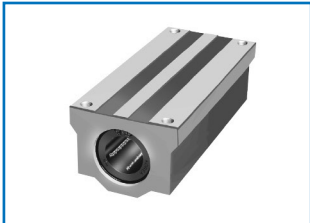

SHW Block



SH-A Block

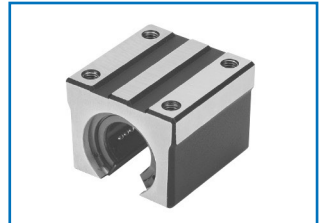

SHO Block

2. European Standard



SBE Bearing



SBEO Bearing



CS Block



CS-A Block



CSW Block



CSW-A Block



CSO Block



CSO-A Block



CSOW Block



CSOW-A Block

3. Inch Standard



SBA Bearing



SBAO Bearing

Super Ball Bushing

3 Life Span

As long as the linear system is reciprocated while being loaded, continuous stress acts on the linear system to cause 'flaking' on the rolling bodies and raceway surface because of material fatigue. The traveling distance of linear system until the first flaking occurs is called the life of the system.

1. Basic Dynamic Load Rating (C)

The term is arrived at based on an evaluation of a number of identical linear systems individually run in the same conditions. If 90% of them can run with the load (with a constant value in a constant direction) for a distance of 50×10^3 meters without damage caused by rolling fatigue. This is the basis of this rating.

2. Hardness factor (f_H)

The shaft must be sufficiently hardened when a side bushing is used. If not properly hardened, permissible load is lowered and the life of the bushing will be shortened. If the temperature of the linear systems exceeds 100°C , the rating life will be shortened.

$$L = \left(\frac{C}{P} \cdot f_H \cdot f_T \cdot f_D \right)^3 \cdot 50 (\text{km})$$

- L : Running distance life (km)
 C : Basic dynamic load rating (N)
 T : Basic dynamic torque (N·m)
 P : Applied load (N)
 f_H : Hardness factor (fig 5.)
 f_T : Temperature factor (fig 6.)
 f_D : Load direction factor (fig 8.)

$$L_h = \frac{L \cdot 10^3}{2 \times l_s \times n_1 \times 60} (\text{hr})$$

- L_h : Service life (hr)
 L : Running distance life (km)
 l_s : Stroke Length (m)
 n_1 : Number of strokes per minute (o.p.m)

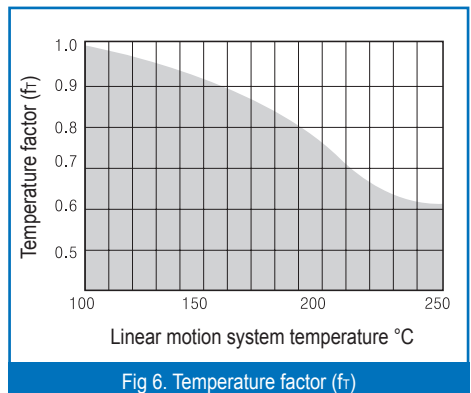
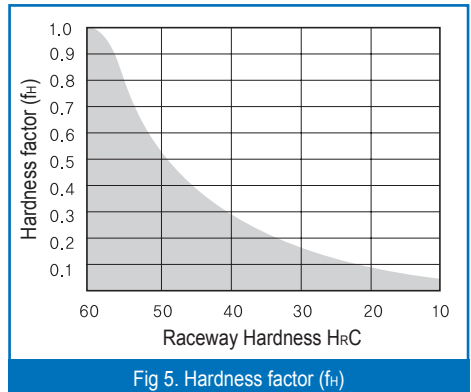

3. Temperature factor (f_T)

If the temperature of the linear system exceeds 100°C, the rating life span will be shortened. (fig 6.)

4. Load direction factor (f_D)

The stated load capacities in dimension table are valid for installation in 'min' position. (fig 7.) If the load is acting in any other direction, these load capacities must be changed by factor 'C' and 'C0' as (fig 8.)

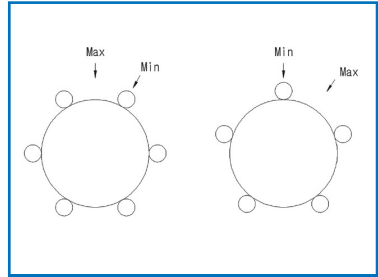

Fig 7. Direction of load and load capacity

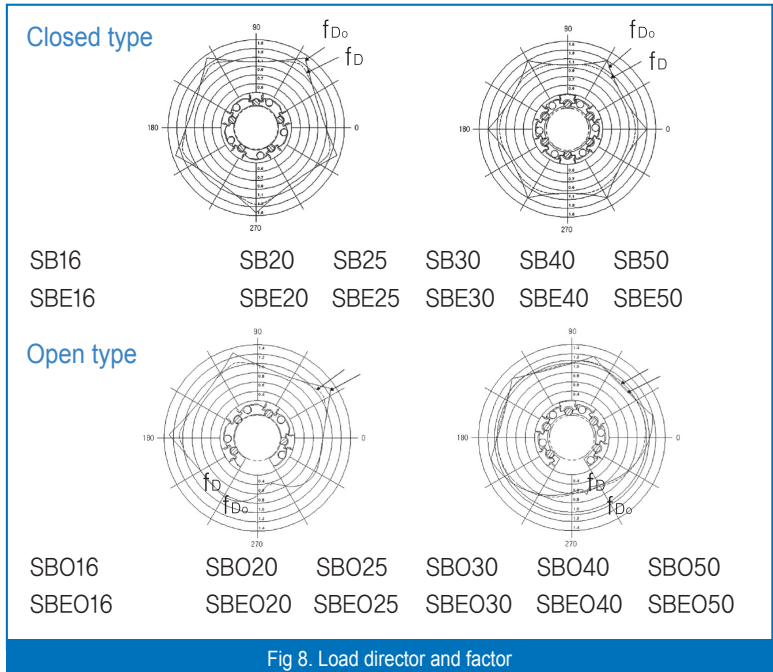

Fig 8. Load director and factor

5. Basic Static Load Rating (C_0)

This term defines a static load such that, at the contacting position where the maximum stress is exceeded, the sum of the permanent deformation of the rolling plane is 0.0001 time of the diameter of the rolling elements. If inertia force exceeds the Static Load C_0 by vibration, shock or high speed, the linear motion would be rough as well as the life would be very reduced. Thus, these points should be paid attention to.

6. Housing and Shaft tolerance

Housing is essential to use WON Super Ball Bushing and service life and accuracy is affected by the inner tolerance of housing.

You can refer to table 2~7 about housing and shaft tolerance to use Super Ball Bushing.

Housing tolerance

Table 2. Asian type

Unit : mm

Part No.	SB 16	SB 20	SB 25	SB 30	SB 40
Inner Diameter(D)	28	32	40	45	60
Tolerance(H7)	+0.021 0		+0.025 0		+0.030 0

Table 3. European type

Unit : mm

Part No.	SB 16	SBE 20	SBE 25	SBE 30	SBE 40	SBE 50
Inner Diameter(D)	26	32	40	47	62	75
Tolerance(H7)	+0.021 0		+0.025 0		+0.030 0	

Table 4. INCH type

Unit : mm

Part No.	SBA 4	SBA 6	SBA 8	SBA 10	SBA 12	SBA 16	SBA 20	SBA24
Inner Diameter(D)	0.5	0.625	0.875	1.125	1.25	1.5625	2	2.375
Tolerance(H7)	+0.0007 0		+0.0008 0		+0.0010 0		+0.0012 0	

Shaft tolerance

Table 5. Asian type

Unit : mm

Part No.	SB 16	SB 20	SB 25	SB 30	SB 40
Shaft Diameter	16	20	25	45	60
Tolerance(h6)	0 -0.011		0 -0.013		0 -0.016

Table 6. European type

Unit : mm

Part No.	SB 16	SBE 20	SBE 25	SBE 30	SBE 40	SBE 50
Shaft Diameter	16	20	25	30	40	50
Tolerance(h6)	0 -0.011		0 -0.013		0 -0.016	

Table 7. INCH type

Unit : mm

Part No.	SBA 4	SBA 6	SBA 8	SBA 10	SBA 12	SBA 16	SBA 20	SBA 24
Shaft Diameter	0.25	0.375	0.5	0.625	0.75	1	1.25	1.5
Tolerance(h6)	-0.0002 -0.0006		-0.0002 -0.0007		-0.0003 -0.0008		-0.0004 -0.0010	

4 Assembly

WON Super Ball Bushing is very precise so it must be handled with meticulous care. Use of a jig (see illustration) is recommended for insertion into a housing and Care should be taken not to exert pressure on the ball retainer or seals.

The edge of the housing bore must be chamfered as well as the ends of the shaft are also chamfered. And the WON Super Bushing is not tilted when it is pushed onto the shaft.

Reducing load capacity in short-stroke application

In short stroke application the service life of the WON shafts is shorter than that of the Super Ball Bushing. For this reason the life can be shorten up to about 70% by the stroke.

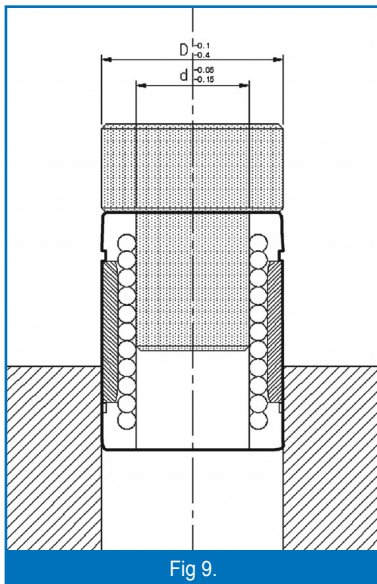

Fig 9.

SB type

Asian Super Ball Bushing



Closed type

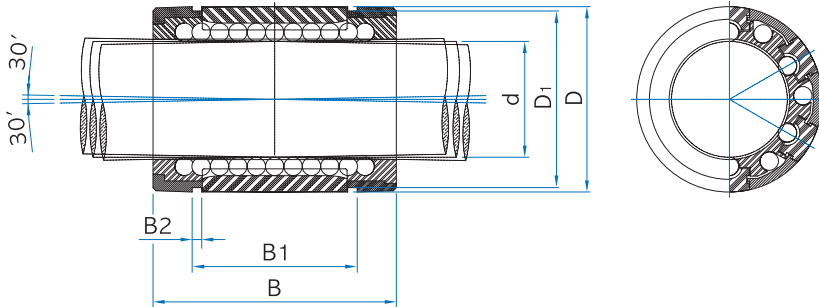

Unit : mm

Part No.			Dimensions					Shaft d	No. Ball rows	Basic Load Ratings		
Without Seal	With One Seal	With Two Seal	D	D ₁	B	B ₁	B ₂			dyn. C (N)	stat. Co (N)	weight (g)
SB 16	SB 16U	SB 16UU	28	27	37	26,5	1,6	16	5	1240	800	34
SB 20	SB 20U	SB 20UU	32	30,5	42	30,5	1,6	20	6	2280	1400	58
SB 25	SB 25U	SB 25UU	40	38	59	41	1,85	25	6	3980	2465	120
SB 30	SB 30U	SB 30UU	45	43	64	44,5	1,85	30	6	4420	2800	148
SB 40	SB 40U	SB 40UU	60	57	80	60,5	2,1	40	6	8980	5460	314

1N ≅ 0,102kgf

SBO type

Asian Super Ball Bushing

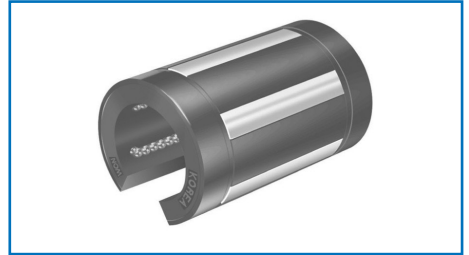

Open type

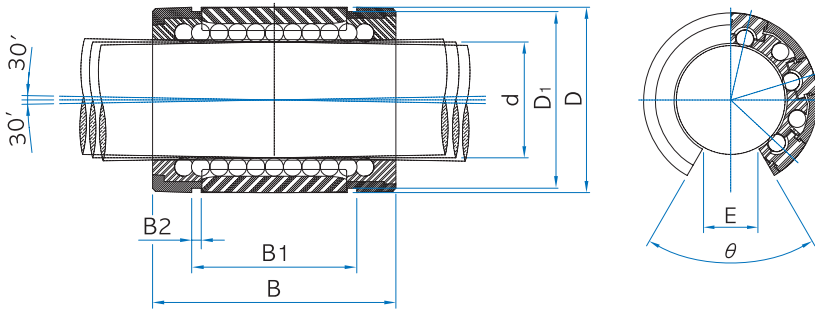

Super Ball Bushing

Unit : mm

Part No.			Dimensions						Angle	Shaft	No. Ball rows	Basic Load Ratings		weight (g)
Without Seal	With One Seal	With Two Seal	D	D ₁	B	B ₁	B ₂	E	θ	d		dyn. C (N)	stat. Co (N)	
SBO 16	SBO 16U	SBO 16UU	28	27	37	26.5	1.6	11	60°	16	4	1410	960	26
SBO 20	SBO 20U	SBO 20UU	32	30.5	42	30.5	1.6	11	60°	20	5	2300	1430	48
SBO 25	SBO 25U	SBO 25UU	40	38	59	41	1.85	12.5	60°	25	5	4030	2540	100
SBO 30	SBO 30U	SBO 30UU	45	43	64	44.5	1.85	15	60°	30	5	4475	2890	122
SBO 40	SBO 40U	SBO 40UU	60	57	80	60.5	2.1	20	60°	40	5	9100	5625	262

1N ≙ 0.102kgf

SH type

Asian Super Ball Bushing Block

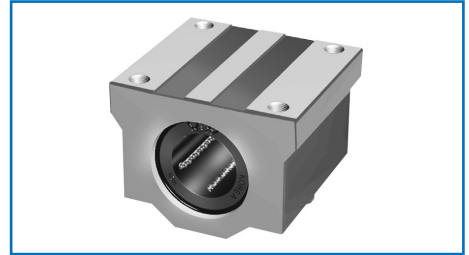

Closed type(with 1pc of SB)

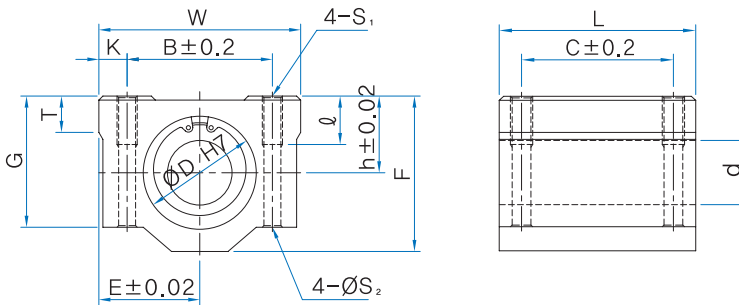

Unit : mm

Part No.	Dimensions								Mounting Dimensions					Shaft d	Basic Load Ratings		weight (g)	
	D	h	E	W	L	F	G	T	B	C	K	S ₁	S ₂		ℓ	dyn. C (N)		stat. Co (N)
SH 16UU	28	19	25	50	44	38,5	32,5	9	36	34	7	M5	4,3	12	16	1225	637	148
SH 20UU	32	21	27	54	50	41	35	11	40	40	7	M6	5,2	12	20	2303	1225	198
SH 25UU	40	26	38	76	67	51,5	42	12	54	50	11	M8	7	18	25	4312	2058	472
SH 30UU	45	30	39	78	72	59,5	49	15	58	58	10	M8	7	18	30	4802	2548	589
SH 40UU	60	40	51	102	90	78	62	20	80	60	11	M10	8,7	25	40	9310	4312	1225
SH 50UU	80	52	61	122	110	102	80	25	100	80	11	M10	8,7	25	50	13132	6468	2420

1N ≒ 0.102kgf

SHW type

Asian Super Ball Bushing Block

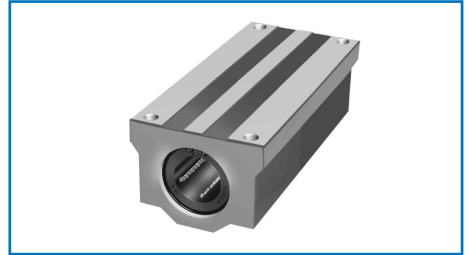

Double Closed type(with 2pcs of SB)

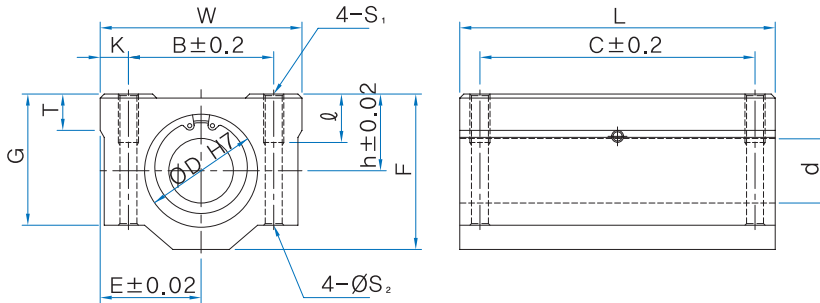

Super Ball Bushing

Unit : mm

Part No.	Dimensions								Mounting Dimensions						Shaft d	Basic Load Ratings		weight (g)
	D	h	E	W	L	F	G	T	B	C	K	S ₁	S ₂	ℓ		dyn. C (N)	stat. C ₀ (N)	
SHW 16UU	28	19	25	50	85	38.5	32.5	9	36	60	7	M5	4.3	12	16	1989	1274	308
SHW 20UU	32	21	27	54	96	41	35	11	40	70	7	M6	5.2	12	20	3734	2450	422
SHW 25UU	40	25	38	76	130	51.5	42	12	54	100	11	M8	7	18	25	6987	4116	972
SHW 30UU	45	30	39	78	140	59.5	49	15	58	110	10	M8	7	18	30	7781	5096	1180
SHW 40UU	60	40	51	102	175	78	62	20	80	140	11	M10	8.7	25	40	15092	8624	2461

1N ≒ 0.102kgf

SH-A type

Asian Super Ball Bushing Block

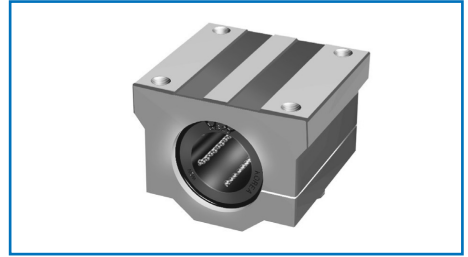

Closed adjustable clearance type(with 1pc of SB)

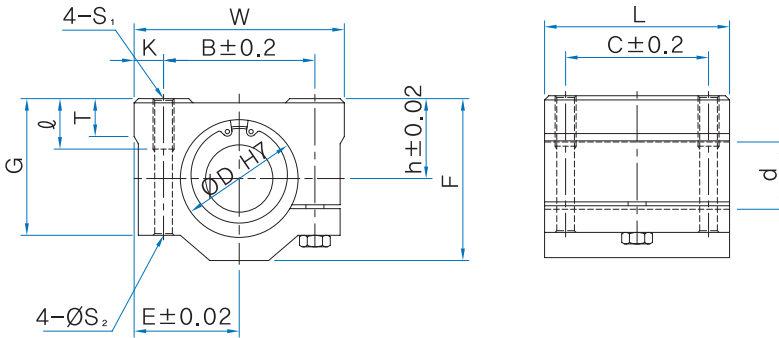

Unit : mm

Part No.	Dimensions								Mounting Dimensions					Shaft d	Basic Load Ratings		weight (g)	
	D	h	E	W	L	F	G	T	B	C	K	S ₁	S ₂		ℓ	dyn. C (N)		stat. Co (N)
SH 16AUU	28	19	25	50	44	38.5	32.5	9	36	34	7	M5	4.3	12	16	1225	637	160
SH 20AUU	32	21	27	54	50	41	35	11	40	40	7	M6	5.2	12	20	2303	1225	218
SH 25AUU	40	26	38	76	67	51.5	42	12	54	50	11	M8	7	18	25	4312	2058	490
SH 30AUU	45	30	39	78	72	59.5	49	15	58	58	10	M8	7	18	30	4802	2548	610
SH 40AUU	60	40	51	102	90	78	62	20	80	60	11	M10	8.7	25	40	9310	4312	1200
SH 50AUU	80	52	61	122	110	102	80	25	100	80	11	M10	8.7	25	50	13132	6468	-

1N ≅ 0.102kgf

SHO type

Asian Super Ball Bushing Block



Open type(with 1pc of SBO)

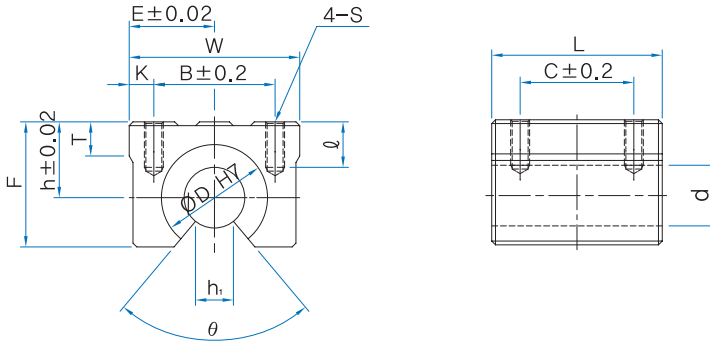

Super Ball Bushing

Unit : mm

Part No.	Dimensions									Mounting Dimensions					Shaft d	Basic Load Ratings		
	D	h	E	W	L	F	T	h ₁	θ	B	C	K	S	ℓ		dyn. C (N)	stat. Co (N)	weight (g)
SHO 16UU	28	20	22.5	45	45	33	9	11	60°	32	30	6.5	M5	12	16	1372	754	124
SHO 20UU	32	23	24	48	50	39	11	11	60°	35	35	6.5	M6	12	20	2332	1244	178
SHO 25UU	40	27	30	60	65	47	14	12.5	60°	40	40	10	M6	12	25	4351	2097	352
SHO 30UU	45	33	35	70	70	56	15	15	60°	50	50	10	M8	18	30	4851	2997	507
SHO 40UU	60	42	45	90	90	72	20	20	60°	65	65	12.5	M10	20	40	9408	4410	1055

1N ≙ 0.102kgf

SBE type

European Super Ball Bushing



Closed type

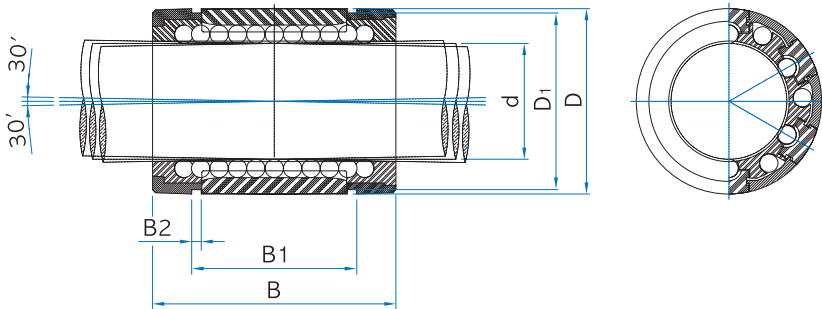

Unit : mm

Part No.			Dimensions					Shaft d	No. Ball rows	Basic Load Ratings		weight (g)
without Seal	without One Seal	without Two Seal	D	D ₁	B	B ₁	B ₂			dyn. C (N)	stat. C ₀ (N)	
SBE 16	SBE 16U	SBE 16UU	26	24,9	36	24,6	1,3	16	5	1140	710	26
SBE 20	SBE 20U	SBE 20UU	32	30,5	45	31,2	1,6	20	6	2280	1400	60
SBE 25	SBE 25U	SBE 25UU	40	38,5	58	43,7	1,85	25	6	4280	2740	120
SBE 30	SBE 30U	SBE 30UU	47	44,5	68	51,7	1,85	30	6	5020	3365	184
SBE 40	SBE 40U	SBE 40UU	62	58,5	80	60,3	2,15	40	6	8980	5460	342
SBE 50	SBE 50U	SBE 50UU	75	71,5	100	77,3	2,65	50	6	12965	7940	586

1N \approx 0.102kgf

SBE0 type

European Super Ball Bushing



Open type

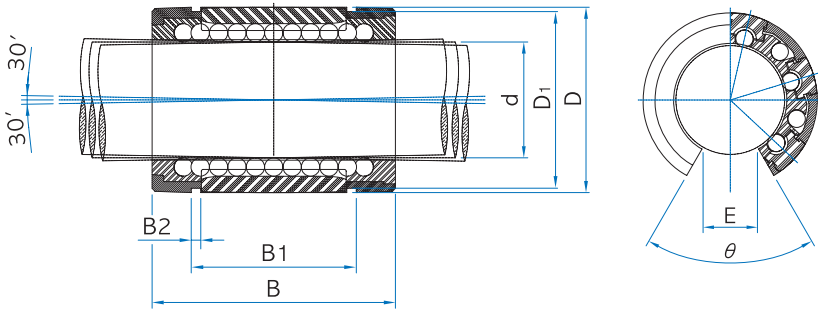

Super Ball Bushing

Unit : mm

Part No.			Dimensions						Angle	Shaft	No. Ball rows	Basic Load Ratings		weight (g)
without Seal	without One Seal	without Two Seal	D	D ₁	B	B ₁	B ₂	E				d	dyn. C (N)	
SBE0 16	SBE0 16U	SBE0 16UU	26	24.9	36	24.6	1.3	9	68°	16	4	1330	910	20
SBE0 20	SBE0 20U	SBE0 20UU	32	30.5	45	31.2	1.6	9	55°	20	5	2310	1445	50
SBE0 25	SBE0 25U	SBE0 25UU	40	38.5	58	43.7	1.85	11.5	57°	25	5	4330	2820	100
SBE0 30	SBE0 30U	SBE0 30UU	47	44.5	68	51.7	1.85	14	57°	30	5	5080	3460	154
SBE0 40	SBE0 40U	SBE0 40UU	62	58.5	80	60.3	2.15	19.5	56°	40	5	9095	5625	286
SBE0 50	SBE0 50U	SBE0 50UU	75	71.5	100	77.3	2.65	22.5	54°	50	5	13130	8175	486

1N ≅ 0.102kgf

CS type

European Super Ball Bushing Block

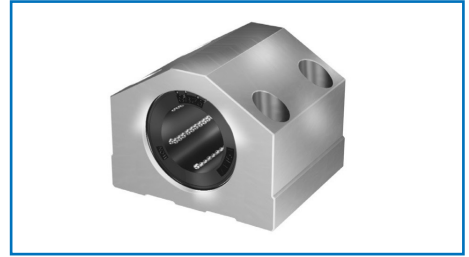

Closed type (with 1pc of SBE)

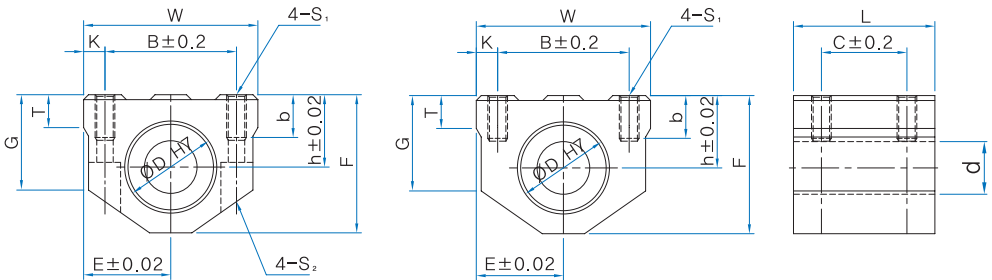

B Type

Unit : mm

Part No.	Dimensions								Mounting Dimensions				Shaft d	No. Ball rows	Basic Load Ratings				
	D	h	E	W	L	F	G	T	B	C	K	b			S ₁	S ₂	dyn. C (N)	stat. Co (N)	weight (g)
CS 16UU	26	22	26.5	53	43	42	29	10	40	26	6.5	13	M6	-	16	5	1176	607	204
CS 16UU-B																			
CS 20UU	32	25	30	60	54	50	34	12	45	32	7.5	18	M8	-	20	6	2352	1254	340
CS 20UU-B																			
CS 25UU	40	30	39	78	67	60	40	15	60	40	9	22	M10	-	25	6	4508	2195	636
CS 25UU-B																			
CS 30UU	47	35	43.5	87	79	70	48	17	68	45	9.5	22	M10	-	30	6	5586	2959	970
CS 30UU-B																			
CS 40UU	62	45	54	108	91	90	62	22	86	58	11	26	M12	-	40	6	9310	4312	1740
CS 40UU-B																			
CS 50UU	75	50	66	132	113	105	68	25	108	50	12	34	M16	-	50	6	13720	6762	2922
CS 50UU-B																			

1N ≒ 0.102kgf

CS-A type

European Super Ball Bushing Block

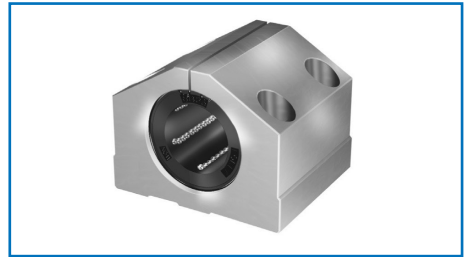

Closed adjustable clearance type(with 1pc of SBE)

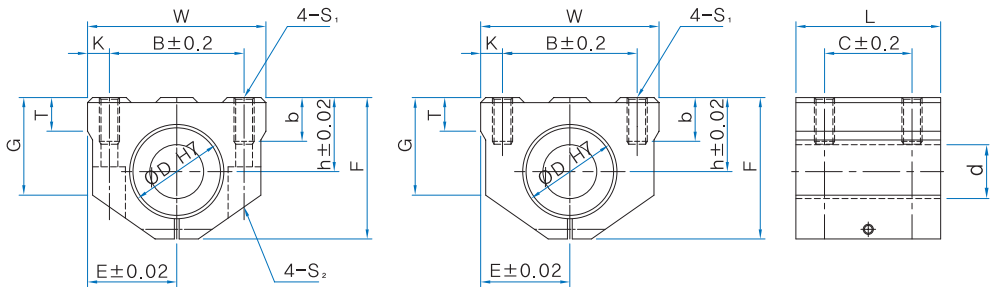

B Type

Unit : mm

Part No.	Dimensions								Mounting Dimensions				Shaft d	No. Ball rows	Basic Load Ratings		weight (g)		
	D	h	E	W	L	F	G	T	B	C	K	b			S ₁	S ₂		dyn. C (N)	stat. Co (N)
CS 16AUU	26	22	26.5	53	43	42	29	10	40	26	6.5	13	M6	-	16	5	1176	607	192
CS 16AUU-B														M5					
CS 20AUU	32	25	30	60	54	50	34	12	45	32	7.5	18	M8	-	20	6	2352	1254	322
CS 20AUU-B														M6					
CS 25AUU	40	30	39	78	67	60	40	15	60	40	9	22	M10	-	25	6	4508	2195	632
CS 25AUU-B														M8					
CS 30AUU	47	35	43.5	87	79	70	48	17	68	45	9.5	22	M10	-	30	6	5586	2959	965
CS 30AUU-B														M8					
CS 40AUU	62	45	54	108	91	90	62	22	86	58	11	26	M12	-	40	6	9310	4312	1736
CS 40AUU-B														M10					
CS 50AUU	75	50	66	132	113	105	68	25	108	50	12	34	M16	-	50	6	13720	6762	2910
CS 50AUU-B														M12					

1N ≙ 0.102kgf

CSW type

European Super Ball Bushing Block



Double closed type(with 2pcs of SBE)

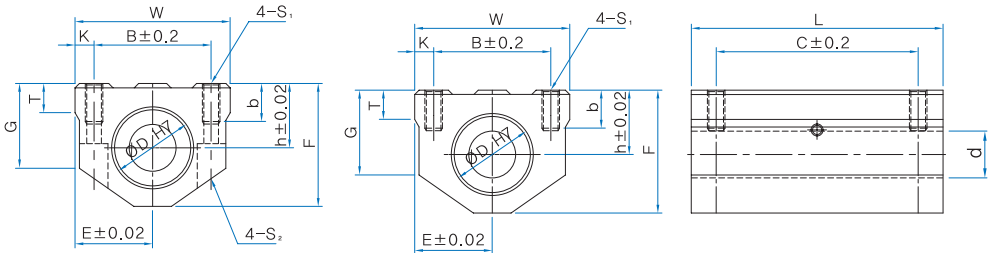

B Type

Unit : mm

Part No.	Dimensions								Mounting Dimensions				Shaft d	No. Ball rows	Basic Load Ratings		weight (g)		
	D	h	E	W	L	F	G	T	B	C	K	b			S ₁	S ₂		dyn. C (N)	stat. Co (N)
CSW 16UU	26	22	26.5	53	84	42	29	10	40	64	6.5	13	M6	—	16	5	1911	1215	380
CSW 16UU-B													M5	—					
CSW 20UU	32	25	30	60	104	50	34	12	45	76	7.5	18	M8	—	20	6	3812	2508	640
CSW 20UU-B													M6	—					
CSW 25UU	40	30	39	78	130	60	40	15	60	94	9	22	M10	—	25	6	7310	4390	1248
CSW 25UU-B													M8	—					
CSW 30UU	47	35	43.5	87	152	70	48	17	68	106	9.5	22	M10	—	30	6	9055	5919	1890
CSW 30UU-B													M8	—					
CSW 40UU	62	45	54	108	176	90	62	22	86	124	11	26	M12	—	40	6	15092	8624	3404
CSW 40UU-B													M10	—					
CSW 50UU	75	50	66	132	224	105	68	25	108	160	12	35	M16	—	50	6	22246	13524	5856
CSW 50UU-B													M12	—					

1N ≒ 0.102kgf

CSW-A type

European Super Ball Bushing Block



Double closed adjustable clearance type(with 2pcs of SBE)

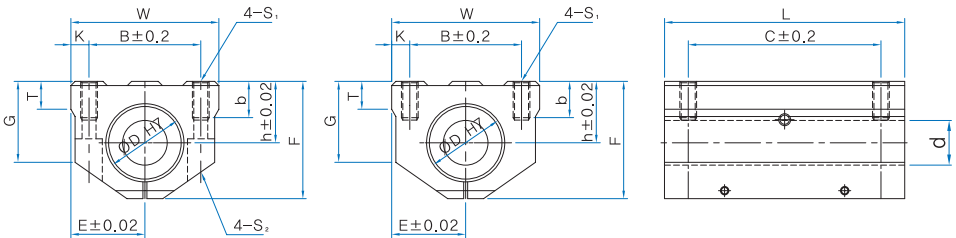

B Type

Unit : mm

Part No.	Dimensions							Mounting Dimensions					Shaft d	No. Ball rows	Basic Load Ratings		weight (g)		
	D	h	E	W	L	F	G	T	B	C	K	b			S ₁	S ₂		dyn. C (N)	stat. Co (N)
CSW 16AUU	26	22	26.5	53	84	42	29	10	40	64	6.5	12	M6	-	16	5	1911	1215	364
CSW 16AUU-B														M5					
CSW 20AUU	32	25	30	60	104	50	34	12	45	76	7.5	18	M8	-	20	6	3812	2568	614
CSW 20AUU-B														M6					
CSW 25AUU	40	30	39	78	130	60	40	15	60	94	9	25	M10	-	25	6	7310	4390	1212
CSW 25AUU-B														M8					
CSW 30AUU	47	35	43.5	87	152	70	48	17	68	106	9.5	25	M10	-	30	6	9055	5919	1252
CSW 30AUU-B														M8					
CSW 40AUU	62	45	54	108	176	90	62	22	86	124	11	25	M12	-	40	6	15092	8624	3310
CSW 40AUU-B														M10					
CSW 50AUU	75	50	66	132	224	105	68	25	108	160	12	35	M16	-	50	6	22246	13524	5856
CSW 50AUU-B														M12					

1N ≒ 0.102kgf

CSO type

European Super Ball Bushing Block

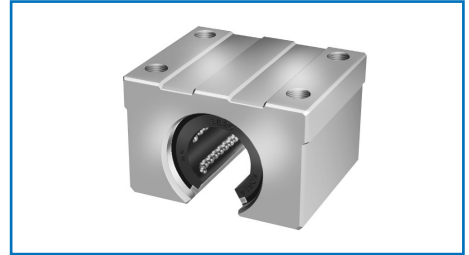

Open type (with 1pc of SBEO)

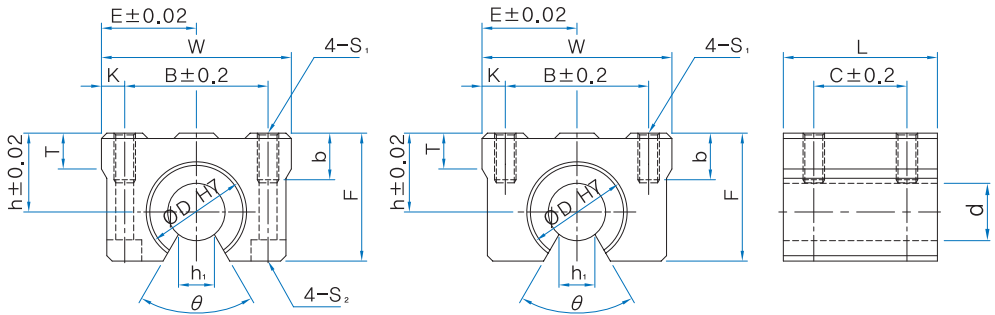

B Type

Unit : mm

Part No.	Dimensions									Mounting Dimensions						Shaft D	No. Ball rows	Basic Load Ratings		
	D	h	E	W	L	F	T	h ₁	θ	B	C	K	b	S ₁	S ₂			dyn. C (N)	stat. Co (N)	weight (g)
CSO 16UU	26	22	26.5	53	43	35	8	9	68°	40	26	6.5	13	M6	-	16	4	1332	715	160
CSO 16UU-B															M5					
CSO 20UU	32	25	30	60	54	42	10	9	55°	45	32	7.5	18	M8	-	20	5	2371	1274	280
CSO 20UU-B															M6					
CSO 25UU	40	30	39	78	67	51	13	11.5	57°	60	40	9	22	M10	-	25	5	4557	2234	552
CSO 25UU-B															M8					
CSO 30UU	47	35	43.5	87	79	60	15	14	57°	68	45	9.5	22	M10	-	30	5	5644	3018	846
CSO 30UU-B															M8					
CSO 40UU	62	45	54	108	91	77	20	19.5	56°	86	58	11	26	M12	-	40	5	9398	4410	1516
CSO 40UU-B															M10					
CSO 50UU	75	50	66	132	113	88	25	22.5	54°	108	50	12	34	M16	-	50	5	13857	6860	2546
CSO 50UU-B															M12					

1N ≅ 0.102kgf

CSO-A type

European Super Ball Bushing Block

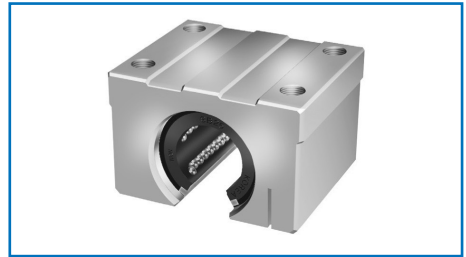

Open adjustable clearance type(with 1pc of SBEO)

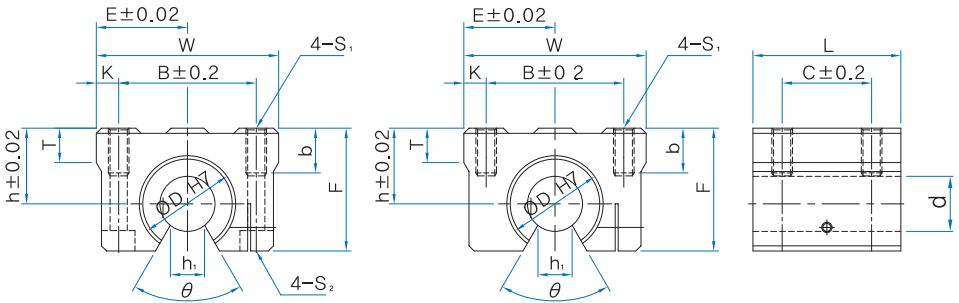

Super Ball Bushing

B Type

Unit : mm

Part No.	Dimensions								Mounting Dimensions						Shaft D	No. Ball rows	Basic Load Ratings		weight (g)	
	D	h	E	W	L	F	T	h ₁	θ	B	C	K	b	S ₁			S ₂	dyn. C (N)		stat. Co (N)
CSO 16AUU	26	22	26.5	53	43	35	8	9	68°	40	26	6.5	13	M6	-	16	4	1332	715	158
CSO 16AUU-B																				
CSO 20AUU	32	25	30	60	54	42	10	9	55°	45	32	7.5	18	M8	-	20	5	2371	1274	277
CSO 20AUU-B																				
CSO 25AUU	40	30	39	78	67	51	13	11.5	57°	60	40	9	22	M10	-	25	5	4557	2234	548
CSO 25AUU-B																				
CSO 30AUU	47	35	43.5	87	79	60	15	14	57°	68	45	9.5	22	M10	-	30	5	5644	3018	840
CSO 30AUU-B																				
CSO 40AUU	62	45	54	108	91	77	20	19.5	56°	86	58	11	26	M12	-	40	5	9398	4410	1510
CSO 40AUU-B																				
CSO 50AUU	75	50	66	132	113	88	25	22.5	54°	108	50	12	34	M16	-	50	5	13857	6860	2535
CSO 50AUU-B																				

1N ≙ 0,102kgf

CSOW type

European Super Ball Bushing Block



Double open type(with 2pcs of SBEO)

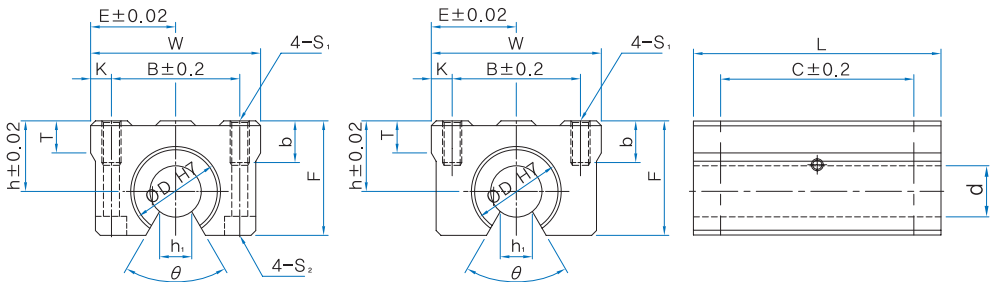

B Type

Unit : mm

Part No.	Dimensions									Mounting Dimensions				Shaft d	No. Ball rows	Basic Load Ratings		weight (g)		
	D	h	E	W	L	F	T	h ₁	θ	B	C	K	b			S ₁	S ₂		dyn. C (N)	stat. Co (N)
CSOW 16UU	26	22	26.5	53	84	35	10	9	68°	40	64	6.5	13	M6	-	16	4	2195	1430	338
CSOW 16UU-B																				
CSOW 20UU	32	25	30	60	104	42	12	9	55°	45	76	7.5	18	M8	-	20	5	3871	2548	552
CSOW 20UU-B																				
CSOW 25UU	40	30	39	78	130	51	15	11.5	57°	60	94	9	22	M10	-	25	5	9408	4468	1092
CSOW 25UU-B																				
CSOW 30UU	47	35	43.5	87	152	60	17	14	57°	68	106	9.5	22	M10	-	30	5	9212	6036	1656
CSOW 30UU-B																				
CSOW 40UU	62	45	54	108	176	77	22	19.5	56°	86	124	11	26	M12	-	40	5	15288	8820	3062
CSOW 40UU-B																				
CSOW 50UU	75	50	66	132	224	88	25	22.5	54°	108	160	12	35	M16	-	50	5	21854	13720	5042
CSOW 50UU-B																				

1N ≙ 0.102kgf

CSOW-A type

European Super Ball Bushing Block

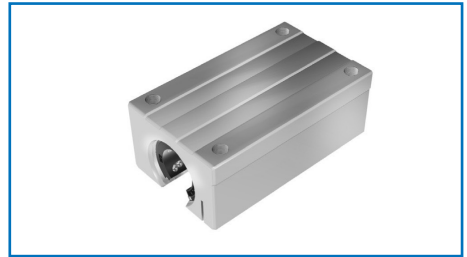

Double Open adjustable clearance type(with 2pcs of SBEO)

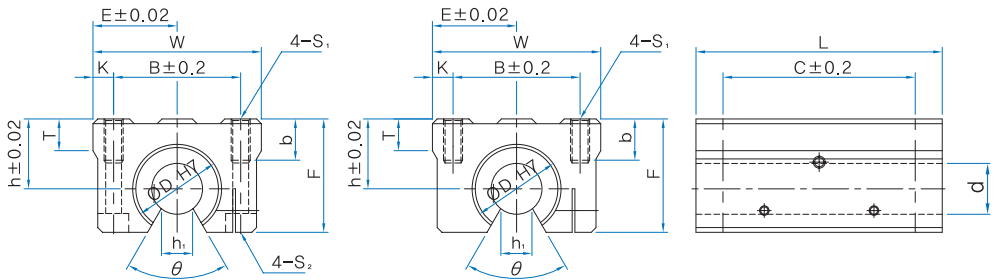

Super Ball Bushing

B Type

Unit : mm

Part No.	Dimensions								Mounting Dimensions						Shaft d	No. Ball rows	Basic Load Ratings		weight (g)	
	D	h	E	W	L	F	T	h ₁	θ	B	C	K	b	S ₁			S ₂	dyn. C (N)		stat. Co (N)
CSOW 16AUU	26	22	26.5	53	84	35	10	9	68°	40	64	6.5	13	M6	-	16	4	2195	1430	330
CSOW 16AUU-B														M5						
CSOW 20AUU	32	25	30	60	104	42	12	9	55°	45	76	7.5	18	M8	-	20	5	3871	2548	540
CSOW 20AUU-B														M6						
CSOW 25AUU	40	30	39	78	130	51	15	11.5	57°	60	94	9	22	M10	-	25	5	9408	4468	1080
CSOW 25AUU-B														M8						
CSOW 30AUU	47	35	43.5	87	152	60	17	14	57°	68	106	9.5	22	M10	-	30	5	9212	6036	1645
CSOW 30AUU-B														M8						
CSOW 40AUU	62	45	54	108	176	77	22	19.5	56°	86	124	11	26	M12	-	40	5	15288	8820	3045
CSOW 40AUU-B														M10						
CSOW 50AUU	75	50	66	132	224	88	25	22.5	54°	108	160	12	35	M16	-	50	5	21854	13720	5030
CSOW 50AUU-B														M12						

1N ≅ 0.102kgf

SBA type

Inch Super Ball Bushing



SBAO type

Inch Super Ball Bushing



Unit : mm

Part No.	No. Ball rows	Weight (N)	Part No.	No. Ball rows	Weight (N)	Shaft d		Dimensions		
						d (inch)	tolerance(inch)	D (inch)	B (inch)	tolerance(inch)
SBA4	4	0.04	-	-	-	0.25	0 -0.0005	0.5	0.75	0 -0.015
SBA6	4	0.06	-	-	-	0.375	0 -0.0005	0.625	0.875	0 -0.015
SBA8	4	0.19	SBAO8	3	0.15	0.5	0 -0.0005	0.875	1.25	0 -0.02
SBA10	5	0.46	SBAO10	4	0.37	0.625	0 -0.0005	1.125	1.5	0 -0.02
SBA12	6	0.55	SBAO12	5	0.45	0.75	0 -0.0005	1.25	1.625	0 -0.02
SBA16	6	1.18	SBAO16	5	0.98	1	0 -0.0005	1.5625	2.25	0 -0.02
SBA20	6	2.16	SBAO20	5	1.86	1.25	0 -0.0005	2	2.625	0 -0.025
SBA24	6	3.34	SBAO24	5	2.84	1.5	0 -0.0005	2.375	3	0 -0.03

Note(1) the upper value in basic load ratings is for SBA series, the lower value is for SBAO series. $1N \approx 0.102kgf$

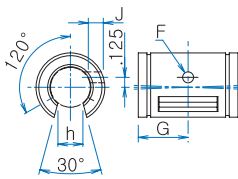
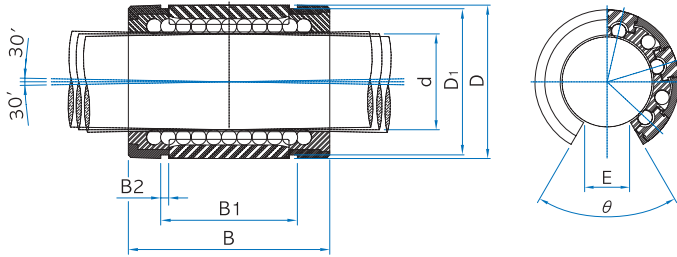

SBA08

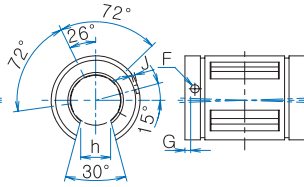

SBA10

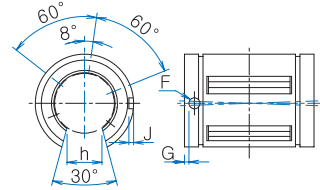

SBA12 ~ SBA024

Unit : mm

B ₁ (inch)	Seal		D ₁ (inch)	Grease inlet				Ball diameter (inch)	Basic Load Rating(1)	
	tolerance (inch)	B ₂ (inch)		h (inch)	F (inch)	G (inch)	J (inch)		dyn. C(N)	stat. Co(N)
SBA4	0 -0.015	0.039	0.4687	-	-	-	-	1/4	255	150
SBA6	0 -0.015	0.039	0.588	-	-	-	-	1/16	390	260
SBA8	0 -0.02	0.0459	0.8209	0.313	0.136	0.625	Thru Hole	3/32	895	570
									1050	710
SBA10	0 -0.02	0.0559	1.059	0.375	0.105	0.125	0.039	1/8	1480	830
									2080	1370
SBA12	0 -0.02	0.0559	1.176	0.438	0.136	0.125	0.059	1/8	2255	1395
									2470	1600
SBA16	0 -0.02	0.0679	1.4687	0.563	0.136	0.125	0.047	5/32	3990	2465
									4630	3070
SBA20	0 -0.025	0.0679	1.8859	0.625	0.201	0.1875	0.09	3/16	5470	3175
									6430	4040
SBA24	0 -0.03	0.0859	2.2389	0.75	0.201	0.1875	0.09	7/32	7640	4345
									8990	5530

1N ≅ 0.102kgf



WON
LINEAR MOTION SYSTEM

Linear Ball Bushing

Contents

1	Linear Ball Bushing	214
2	Types and Characteristics	215
3	Part Number	
	1. Standard Tolerance.....	217
	2. Load Rating & Travel Life.....	217
	3. Calculation Example	218
	4. Calculation of expected Travel Life ..	219
4	Equivalent factor	219
5	Lubrication & Friction	
	1. Grease Lubrication	221
	2. Oil Lubrication.....	221
	3. Coefficient of Friction.....	222
6	Assembly	
	1. Tolerance of Housing Bore	223
	2. Clearance of Outer Sleeve and Shaft	223
	3. Mounting.....	224
	4. Standard type	224
	5. Retaining ring for Mounting	224
	6. Setscrew Mounting Prohibited	224
	7. Flange type.....	225
	8. Mounting of Adjustable type.....	225
	9. Mounting of Open type.....	225
	10. Mounting of Shaft support.....	226
7	Mounting of LM case unit	
	1. Mounting of SH type.....	226
8	Cautions in use	
	1. Mounting of Linear Bushing	226
	2. Insertion of Shaft	227
	3. When Moment loads applied.....	227
	4. Avoid the Rotational Motion	227
	5. Mounting of open type Linear Bushing with three ball rows.....	227

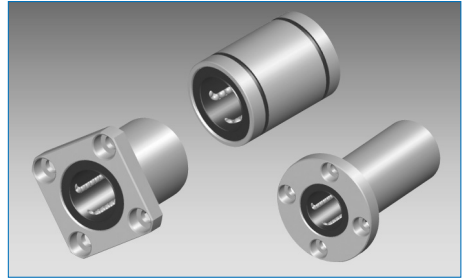

1 Linear Ball Bushing

WON Linear Ball Bushing, LM type, is the linear motion system with unlimited stroke by being applied with LM shaft. Because of the point contact between Balls and LM shaft, the minimum friction can be acquired and can provide you the high-precision motion.

1. Components and Features

As shown in Fig 1. WON Linear Ball Bushing provides the alignment of the balls toward the LM shaft by the single retainer and cylindrical shape of raceway. Outer sleeve is made of high-carbon chromium bearing steel, and does heat treatment and then inner and outer grinding process are applied.

2. Interchangeability

The dimensions of WON Linear Ball Bushing are standardized to have full interchangeability. LM shaft is provided with the cylindrical grinding to have high precision fitting clearance.

3. Rigidity Outer Sleeve

Hardened and precisely ground outer sleeve is made of bearing steel, and can be directly assembled with the needle bearing on outer surface.

4. High precision Retainer

The single body retainer guides 4~6 ball circuits, and it gives the precision guiding against the balls moving direction and smooth motion.

5. Application

WON Linear Ball Bushing is widely used in precision equipments; computer and peripheral equipments, measuring equipments, auto recording equipments, 3D measuring equipments, and linear motion system in machine for mass production; multi-axis drilling machines, punching process, tool grinders, auto-gas cutters, printing machines, card selectors, food packing machines, etc.

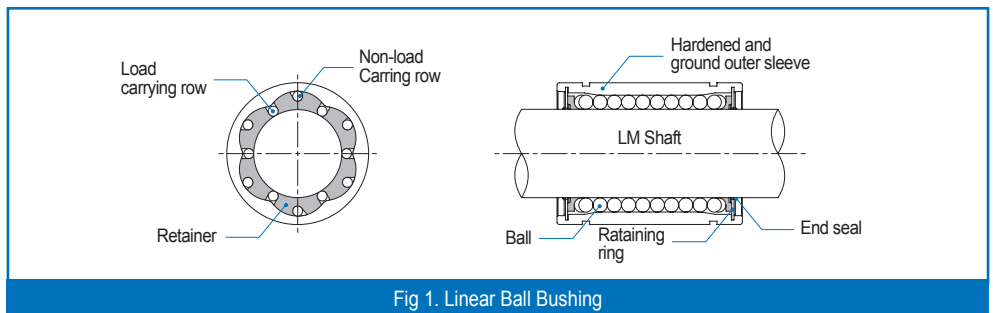

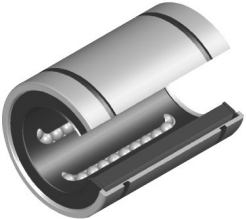

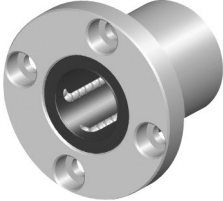
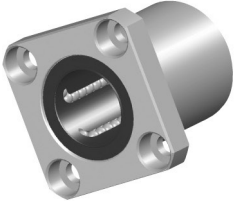
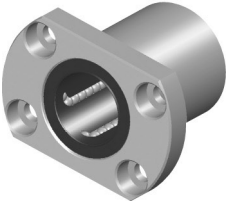
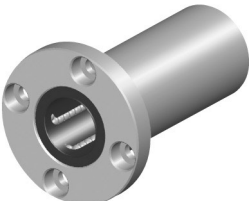

Fig 1. Linear Ball Bushing

2 Types and Characteristics

Classification	Type	Shape and Feature	
Linear Ball Bushing	Standard LM LME		- Cylindrical shape with precision dimension for smoother linear movement.
	Open Type LM□OP LME□OP		- One ball circuit is removed from standard type which provides the maximum rigidity and stiffness when combined with Support Rail Unit.
	Adjustable Clearance Type LM□AJ LME□AJ		- Outer sleeve is slotted in the axial direction to be adjustable the clearance between shaft and Linear Ball Bushing.
	Long Type LM□L LME□L		- Two retainers are installed in Long type (Double-wide type) of outer cylinder for severe moment loads.

Classification	Type	Shape and Feature	
Flange Type Linear Ball Bushing	Round Type LMF		<ul style="list-style-type: none"> - Round Flange Type with mounting holes. - Easier and more compact installation
	Square Type LMK		<ul style="list-style-type: none"> - Square Flange Type with mounting holes. - More compact design is available due to the lower center height.
	Two Side Cut Flange Type LMH		<ul style="list-style-type: none"> - Two Side Cut Flange Type with mounting holes.
	Flanged Long Type LMF□L LMK□L		<ul style="list-style-type: none"> - Two retainers are installed in Long type (Double-wide type) of outer cylinder for severe moment loads.

3 Part Number

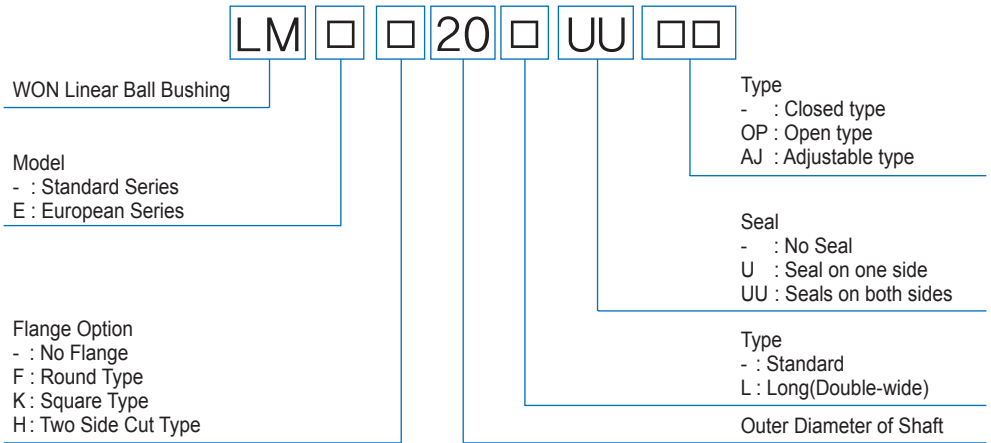

1. Standard Tolerance

The tolerance of inner constant diameter, outside diameter, and length on Linear Ball Bushing are specified on the tables at from 14pages in this catalog, and inner contact diameter and outer diameter for adjustable and open types represents the diameters before being slotted.

2. Load Rating & Travel Life

The load rating of WON Linear Ball Bushing can be affected by the ball position against the load. The basic load rating on the table is that of Linear Ball Bushing when ball circuit is just beneath the load. As shown in Fig 2. If the balls are located in symmetrical position against the load, the load rating will be increased and the travel life will be extended.

$$L = \left(\frac{f_H \cdot f_C \cdot f_T}{f_w} \times \frac{C}{P} \right)^3 \times 50$$

$$L_{100} = \left(\frac{f_H \cdot f_C \cdot f_T}{f_w} \times \frac{C_{100}}{P} \right)^3 \times 100$$

- L : Travel life (km)
- L₁₀₀ : Travel life (km)
- C : Basic dynamic load rating (N)
- C₁₀₀ : Basic dynamic load rating (N)
- P : Applied load
- f_H : Hardness factor
- f_w : Load coefficient
- f_C : Contact factor
- f_T : Temperature factor

Linear Ball Bushing

Fig 2. Load ratings and Ball position

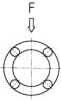
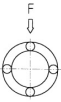
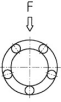
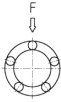
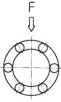
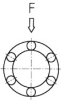
No. of Ball Rows	Ball position		No. of Ball Rows	Ball position		No. of Ball Rows	Ball position	
	Max. Load rating	Min. Load rating		Max. Load rating	Min. Load rating		Max. Load rating	Min. Load rating
4			5			6		
	$F=1.41 \times C$	$F=C$		$F=1.46 \times C$	$F=C$		$F=1.26 \times C$	$F=C$

C : refer to dimensions table

- If a Linear Ball Bushing or two Linear Ball Bushings are applied by the the moment load, the calculation of the equivalent radial load is required.

$$P_U \doteq K \cdot M$$

- P_U : Equivalent radial load (N)
(when the moment is applied)
 - K : Equivalent factor (Refer to table 1~3)
 - M : Applied moment (N · mm)
- P_U should be up to basic load rating

- If the moment load and the radial load are applied, the travel life can be calculated by the sum of the moment load and the radial load. From the above equations, the stroke and number of strokes per minute are constant, the travel life can be calculated by the following equation.

$$L_h = \frac{L \times 10^3}{2 \times \ell_s \times n_1 \times 60}$$

- L_h : Travel life (hr)
- ℓ_s : Stroke (m)
- L : Rated life (Km)
- n_1 : Number of strokes per minute(o.p.m)

- When short stroke is applied, travel life is calculated by basic dynamic load rating multiplied factor K_c on Fig 3.

3. Calculation Example

The Maximum applied load and the travel life are the most important factors for choosing a proper size of Linear Ball Bushing. Belows are the sample calculations of the expecting travel life and choosing a proper Linear Ball Bushing.

-Working conditions-

Operating speed

$$\begin{aligned} V &= 2 \times \ell_s \times n_1 \\ &= 2 \times 0.250 \times 60 \\ &= 30 \text{ m/min} \quad (f_w = 1.6) \end{aligned}$$

- Applied load : 250 N (P)
- Stroke : 0.0250 m (ℓ_s)
- Number of strokes per minute : 60 (n_1)
- Shaft hardness : HRC 60 ($f_H=1.0$)

4. Calculation of expected Travel Life

Assuming the basic dynamic load rating is based on travel life of 50km and all other factor is 1.0, you choose the Linear Ball Bushing size that you can expect the travel life. Let's try LM40UU with the above working conditions.

$$L = \left(\frac{1.0 \times 1.0 \times 1.0}{1.6} \times \frac{2,150}{250} \right)^3 \times 50 \quad L_h = \frac{7,764 \times 10^3}{2 \times 0.250 \times 60 \times 60}$$

$$\doteq 7,764 \text{ km} \quad \doteq 4,313 \text{ hours}$$

Let's assume our design travel life is 15,000hours ;
 $L = 15,000 \times 2 \times 0.250 \times 10^{-3} \times 60 \times 60 = 27,000\text{km}$

$$C = \frac{250 \times 1.6}{1.0 \times 1.0 \times 1.0} \times \sqrt[3]{\frac{27,000}{50}}$$

$$\doteq 3,257 \text{ N}$$

So, the proper Linear Ball Bushing for above condition is LM50UU which has 3,822N(390kgf) as the basic load rating.

4 Equivalent factor

Table 1. Equivalent factor for LM type

Part No.	Equivalent factor : K	
	Single	Double
LM 5	1.253	0.178
LM 6	0.553	0.162
LM 8S	0.708	0.166
LM 8	0.442	0.128
LM 10	0.389	0.101
LM 12	0.389	0.097
LM 13	0.343	0.093
LM 16	0.279	0.084
LM 20	0.257	0.071
LM 25	0.163	0.054
LM 30	0.153	0.049
LM 35	0.143	0.045
LM 40	0.117	0.040
LM 50	0.096	0.032
LM 60	0.093	0.028

Note) the Equivalent factors for LME F/K/H and SH types are same as LM type.

Table 2. Equivalent factor for LM-L type

Part No.	Equivalent factor : K	
	Single	
LM 5L	0.223	
LM 6L	0.201	
LM 8L	0.151	
LM 10L	0.118	
LM 12L	0.113	
LM 13L	0.107	
LM 16L	0.096	
LM 20L	0.082	
LM 25L	0.060	
LM 30L	0.053	
LM 35L	0.050	
LM 40L	0.043	
LM 50L	0.034	
LM 60L	0.031	

Note) the Equivalent factors for LME F/K/H-L types are same as LM-L type.

Table 3. Equivalent factor for LME type

Part No.	Equivalent factor : K	
	Single	Double
LME 5	0.669	0.123
LME 8	0.514	0.116
LME 12	0.389	0.090
LME 16	0.343	0.081
LME 20	0.291	0.063
LME 25	0.209	0.052
LME 30	0.167	0.045
LME 40	0.127	0.039
LME 50	0.105	0.031
LME 60	0.093	0.024

Note) the Equal factors for LME F/K/H and SH types are same as LM type.

Short stroke Application

In applications, when the stroke is short, the life of the shaft is shorter than that of the Linear Ball Bushing. In a short stroke applications, the required dynamic load rating must be multiplied by the factor K_c as found on Fig 3. below.

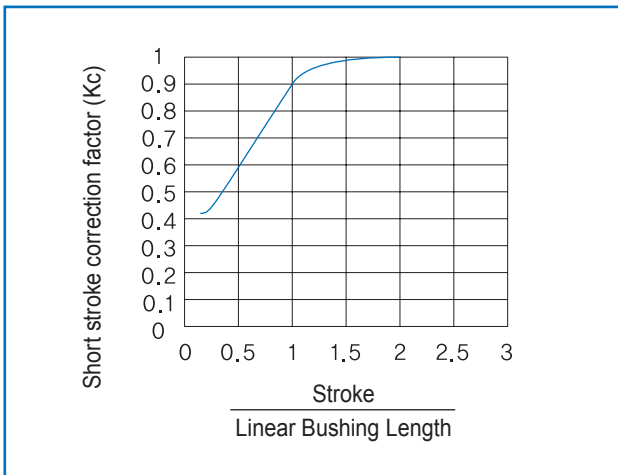
Fig 3. Short stroke correction factor (K_c)

5 Lubrication & Friction

Usually, Linear Ball Bushing is used with grease lubrication or oil lubrication, but in some case, it is used without any lubrication.

1. Grease Lubrication

Before applying the grease, the anticorrosive oil must be removed by kerosene or organic solvent, and apply the grease after drying. Must apply grease directly on the ball for a both side sealed type (..UU). And apply same as above or on the shaft directly for a without sealed type. Lithium soap radical of viscosity mark No. 2 is recommended for use.

2. Oil Lubrication

There is no need to remove anticorrosive oil when oil is used for lubrication. ISO viscosity grade VG15 ~ 100 oil is usually according to the operating temperature.

Operating Temp.	Viscosity
-30°C ~ 50°C	VG 15 ~ 46
50°C ~ 80°C	VG 46 ~ 100

The turbine oil, machine oil, and spindle oil are usually used as lubrication oil. Drop the oil on the shaft for lubrication, or supply it through the oil hole provided on the housing. (Fig 4.) Contact WON for Linear Ball Bushing with lubrication hole for users demands.

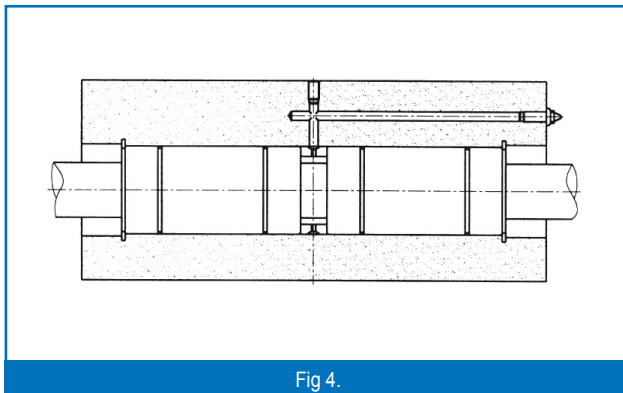

Fig 4.

Because the seals may remove the oil on shaft, oil dropping lubrication is not recommended for both sides seal type.

3. Coefficient of Friction

The balls in a Linear Bushing are the rolling elements, so the balls can reduce the frictional resistance. Static friction is particularly very low, and there is just little difference between static and dynamic friction, so, the stick-slip does not occur. Such low friction make submicron feeding possible. The normal friction coefficient is in Fig 5, and the friction resistance can be calculated by the following equation.

$$F = \mu \cdot P + f_s$$

- F : Friction resistance factor (N)
 f_s : Resistant of Seal (1.3 ~ 204 N)
 P : Applied load (N)
 (Perpendicular load against shaft core)
 μ : Friction coefficient (Static or dynamic)

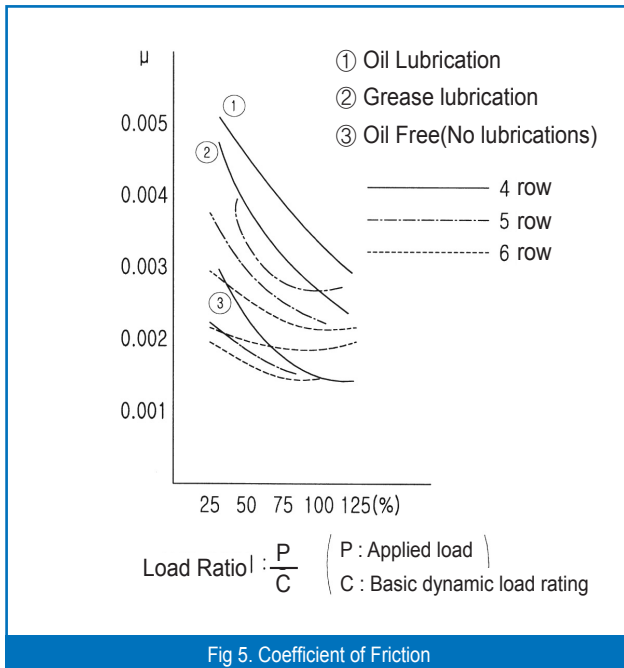

Fig 5. Coefficient of Friction

6 Assembly

1. Tolerance of Housing Bore

Recommended tolerances of Housing bore for WON Linear Ball Bushing are in Table 4. Normal fit is standard, but for without clearance, press fit is also available

Table 4. Tolerance for House Bore

Type		Case	
Part No.	Grade	Normal Fit	Tight Fit
LM	High(H)	H7	J7
LME	–	H7	K6, J6
LMF	–	H7	J7
LMK			
LMH			
LM-L			
LMF-L			
LMK-L			
LMH-L			

2. Clearance of Outer Sleeve and Shaft

Normal fit is standard for using of Linear Bushing with LM shaft, and for without clearance, Tight fit is also available.

Table 5. Tolerance for Shaft Diameter

Type		LM Shaft	
Part No.	Grade	Normal Fit	Tight Fit
LM	High(H)	f6, g6	h6
LME	–	h7	k6
LMF	–	f6, g6	h6
LMK			
LMH			
LM-L			
LMF-L			
LMK-L			
LMH-L			

Note 1) When clearance after installation is required to minus, Allowable value of radial clearance is not allowed to exceed the value in the table.

Note 2) Axial clearance of SH, SHW, SHO type are same as High grade.

3. Mounting

High holding strength toward LM shaft direction is not required, but mounting with press fit only for mounting is not recommended. Please see the table 4 for tolerance of Housing Bore.

4. Standard type

Possible mounting methods are illustrated in Fig 6. and Fig 7. Mount a Linear Ball Bushing with retaining rings and cover plates.

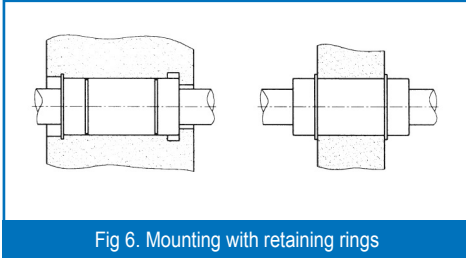

Fig 6. Mounting with retaining rings

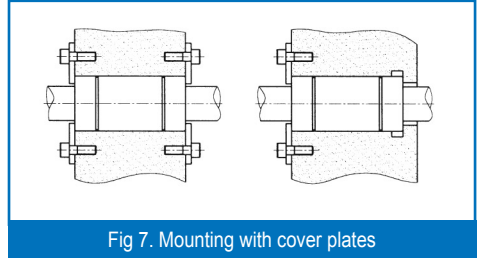

Fig 7. Mounting with cover plates

5. Retaining ring for Mounting

Retaining rings for mounting LM type WON Linear Ball Bushing are used as shown in the below table.

Part No.	Retaining ring			
	External(for shaft)		Internal(for Bore)	
	C type	Needle type	C type	Needle type
LM 5	10	10	10	10
LM 6	12	12	12	12
LM 8	-	15	15	15
LM 8S	-	15	15	15
LM 10	19	19	19	19
LM 12	21	21	21	21
LM 13	23	22	23	-
LM 16	28	-	28	28
LM 20	32	-	32	32
LM 25	40	40	40	40
LM 30	45	45	45	45
LM 35	52	52	52	52
LM 40	-	60	60	60
LM 50	-	80	80	80
LM 60	-	90	90	90

table 6. The information of above table is commonly applied to both LM and LM-L type.

6. Setscrew Mounting Prohibited

Mounting a Linear Ball Bushing with a setscrew as shown in Fig 8. will cause a deformation of the outer sleeve so that it should be avoided.

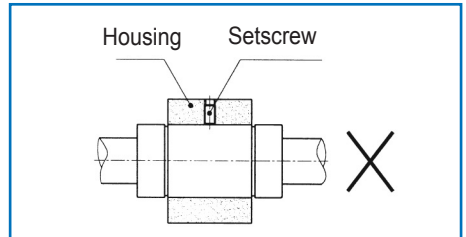
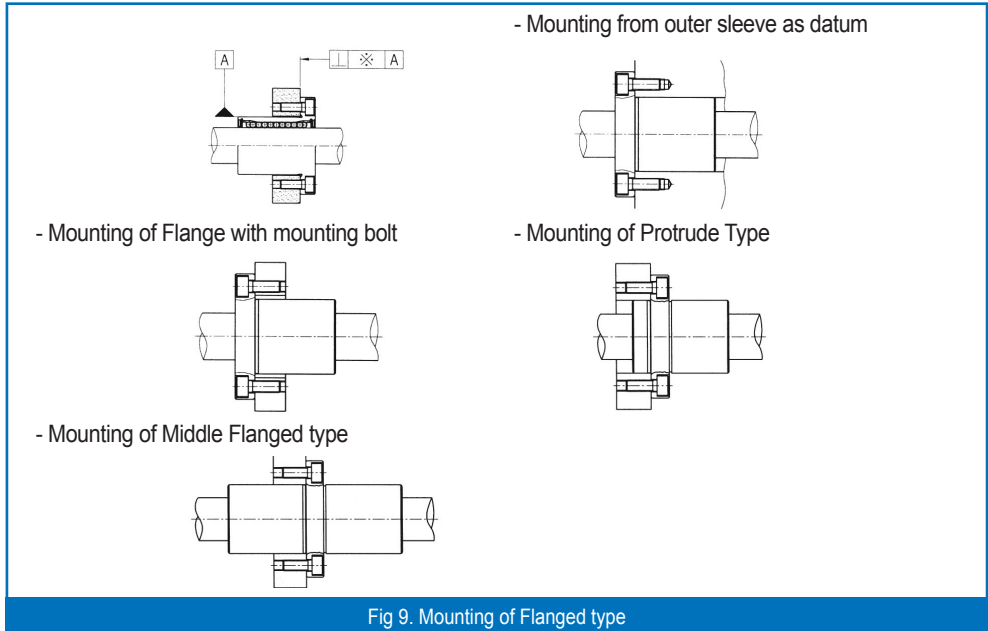

Fig 8. Mounting with Setscrew

7. Flanged type

It is available for flanged types to be mounted itself only with mounting bolt due to its single body shape. note) Geometric dimensional tolerance should be considered when outer sleeve is the datum for installation.



8. Mounting of Adjustable type

Adjustment of clearance for adjustable type (...AZ) and LM shaft can be obtained by assembling with the adjustable type Housing. In the case, the slotted side of Linear Bushing should be located at 90° of open side of housing for uniform deformation in the radial direction. Please see Fig 10.

9. Mounting of Open type

Open type (...OP) also can be used with clearance adjustable housing as shown on Fig 11. Light pre-load is applied for normal using, but heavy pre-load should be avoid.

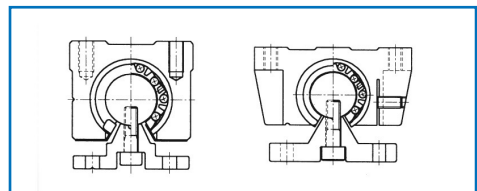
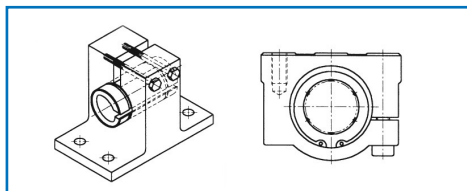

10. Mounting of Shaft support

Shaft support, WK can be mounted with mounting bolt for a table, and LM shaft can be mounted with tightening bolt.

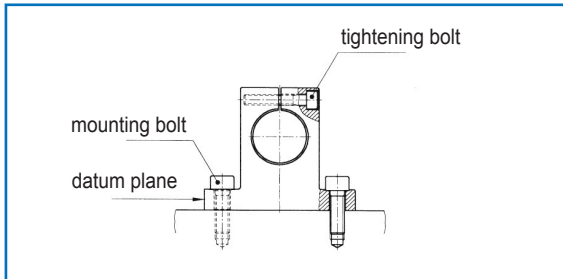

Fig 12. Mounting of Shaft support

7 Mounting of LM case unit

1. Mounting of SH type

Mounting of SH, SHW, SHO type from both the top and bottom side with mounting bolt are available and it gives minimum mounting time.

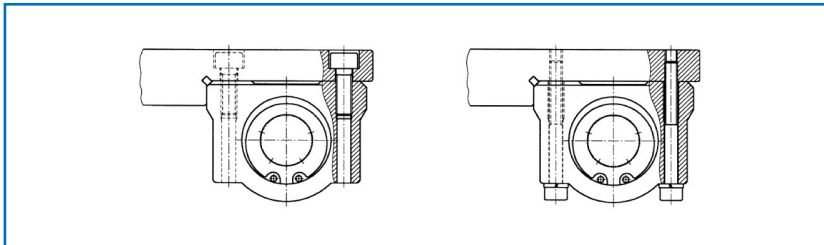

Fig 13. Mounting of Case Unit

8 Cautions in use

1. Mounting of Linear Ball Bushing

For mounting of standard type WON Linear Ball Bushing into the Housing, a jig should be used to avoid direct hitting on the outer sleeve or seal during mounting, See Fig 14.

2. Insertion of Shaft

Care must be taken to align when inserting a shaft into a Linear Ball Bushing. If the shaft is inserted slantly, balls may be departed from the damaged or deformed retainer. See Fig 15.

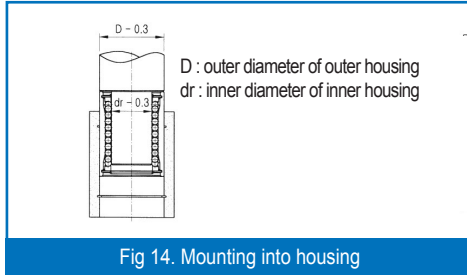

Fig 14. Mounting into housing

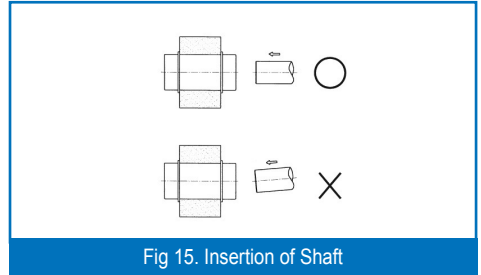

Fig 15. Insertion of Shaft

3. When Moment loads applied

External loads should be distributed uniformly on a Linear Ball Bushing. When moment loads are applied, two or more Linear Bushings should be used on one LM shaft, and the distance between two Linear Ball Bushings should have enough distance.

Calculate the equivalent load when the moment loads are applied and choose the proper Linear Ball Bushing. Please refer to the sample calculation for more information.

4. Avoid the Rotational Motion

WON Linear Ball Bushing is not suitable for rotational motion. See Fig 16. If the Linear Bushing is exposed to rotational motion, it may lead unexpected accidents.

5. Mounting of open type Linear Ball Bushing with three ball rows

Please mount the open type Linear Ball Bushings with three ball circuit as same as Fig 17. for considering of load distribution.

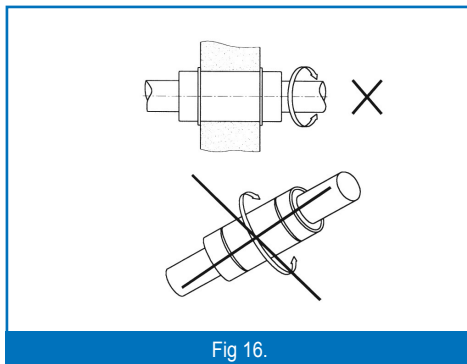

Fig 16.

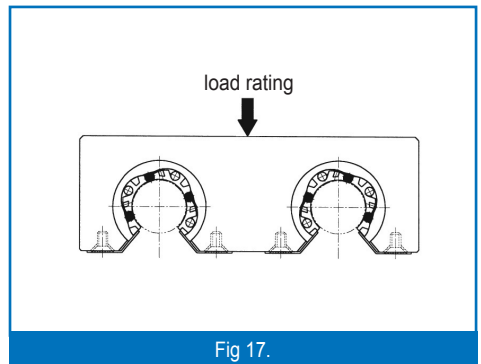
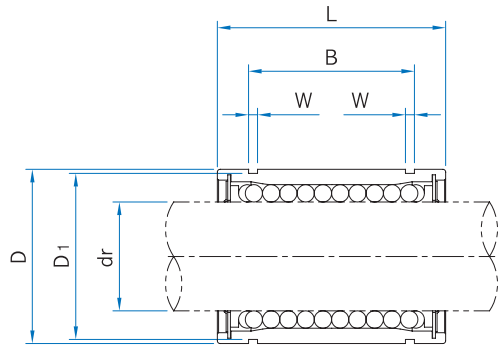
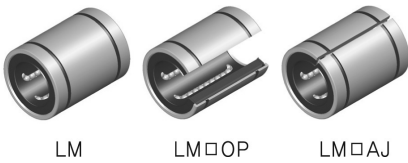

Fig 17.

LM Series



Unit : mm

LM Series						Basic Load Ratings		Working Bore Diameter	
Standard type		Open type(OP)		Adjustable type(AJ)		Dyn C (N)	Stat Co (N)	dr (mm)	ToL. (μ m)
Part No.	No. of Ball circuit	Part No.	No. of Ball circuit	Part No.	No. of Ball circuit				
LM4UU	4	-	-	-	-	88	108	4	$\begin{matrix} 0 \\ -8 \end{matrix}$
LM5UU	4	-	-	-	-	167	206	5	$\begin{matrix} 0 \\ -8 \end{matrix}$
LM6UU	4	-	-	LM 6UUAJ	4	200	260	6	$\begin{matrix} 0 \\ -9 \end{matrix}$
LM8SUU	4	-	-	LM 8SUUAJ	4	170	220	8	
LM8UU	4	-	-	LM 8UUAJ	4	260	400	8	
LM10UU	4	-	-	LM10UUAJ	4	370	540	10	
LM12UU	4	LM12UUOP	3	LM12UUAJ	4	410	590	12	
LM13UU	4	LM13UUOP	3	LM13UUAJ	4	500	770	13	
LM16UU	5	LM16UUOP	4	LM16UUAJ	5	770	1170	16	$\begin{matrix} 0 \\ -10 \end{matrix}$
LM20UU	5	LM20UUOP	4	LM20UUAJ	5	860	1370	20	
LM25UU	6	LM25UUOP	5	LM25UUAJ	6	980	1560	25	
LM30UU	6	LM30UUOP	5	LM30UUAJ	6	1560	2740	30	$\begin{matrix} 0 \\ -12 \end{matrix}$
LM35UU	6	LM35UUOP	5	LM35UUAJ	6	1660	3130	35	
LM40UU	6	LM40UUOP	5	LM40UUAJ	6	2150	4010	40	$\begin{matrix} 0 \\ -15 \end{matrix}$
LM50UU	6	LM50UUOP	5	LM50UUAJ	6	3820	7930	50	
LM60UU	6	LM60UUOP	5	LM60UUAJ	6	4700	9990	60	

Note) Plating and Raydent treatment are available

1N \approx 0.102kgf

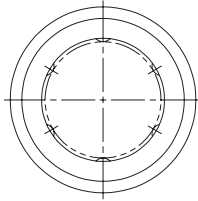

LM

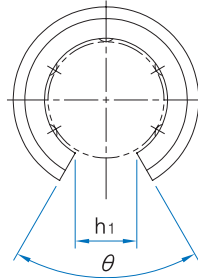

LM□OP

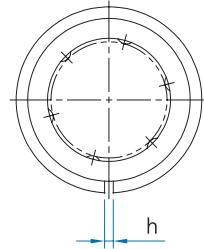

LM□AJ

Unit : mm

Dimensions (mm)											Wgt.* (gf)	Allowable Diametral Clearance (μ m)	Part No.
D (mm)	Tol. (μ m)	L (mm)	Tol. (mm)	B (mm)	Tol. (mm)	W	D ₁	h	h ₁	θ (°)			
8	$\begin{smallmatrix} 0 \\ -9 \end{smallmatrix}$	12	$\begin{smallmatrix} 0 \\ -0.12 \end{smallmatrix}$	-	-	-	-	-	-	-	1.9	-3	LM4UU
10	$\begin{smallmatrix} 0 \\ -8 \end{smallmatrix}$	15	$\begin{smallmatrix} 0 \\ -0.12 \end{smallmatrix}$	10.2	$\begin{smallmatrix} 0 \\ -0.2 \end{smallmatrix}$	1.1	9.6	-	-	-	4	-3	LM5UU
12	$\begin{smallmatrix} 0 \\ -11 \end{smallmatrix}$	19	$\begin{smallmatrix} 0 \\ -0.2 \end{smallmatrix}$	13.5		1.1	11.5	1	-	-	8	-5	LM6UU
15		17		11.5		1.1	14.3	1	-	-	11	-5	LM8SUU
15	24	17.5		1.1		14.3	1	-	-	16	-5	LM8UU	
19	$\begin{smallmatrix} 0 \\ -13 \end{smallmatrix}$	29		22		1.3	18	1	-	-	30	-5	LM10UU
21		30		23		1.3	20	1.5	8	80°	31.5	-5	LM12UU
23	32	23		1.3		22	1.5	9	80°	43	-7	LM13UU	
28	$\begin{smallmatrix} 0 \\ -16 \end{smallmatrix}$	37		26.5		1.6	27	1.5	11	80°	69	-7	LM16UU
32		42		30.5		1.6	30.5	1.5	11	60°	87	-9	LM20UU
40	59	41		$\begin{smallmatrix} 0 \\ -0.3 \end{smallmatrix}$		1.85	38	2	12	50°	220	-9	LM25UU
45	64	44.5			1.85	43	2.5	15	50°	250	-9	LM30UU	
52	$\begin{smallmatrix} 0 \\ -19 \end{smallmatrix}$	70	49.5		2.1	49	2.5	17	50°	390	-13	LM35UU	
60		80	60.5		2.1	57	3	20	50°	585	-13	LM40UU	
80	100	74	2.6		76.5	3	25	50°	1580	-13	LM50UU		
90	$\begin{smallmatrix} 0 \\ -22 \end{smallmatrix}$	110	85		3.15	86.5	3	30	50°	2000	-16	LM60UU	

※ Based on Standard type

1N \approx 0.102kgf

LME Series

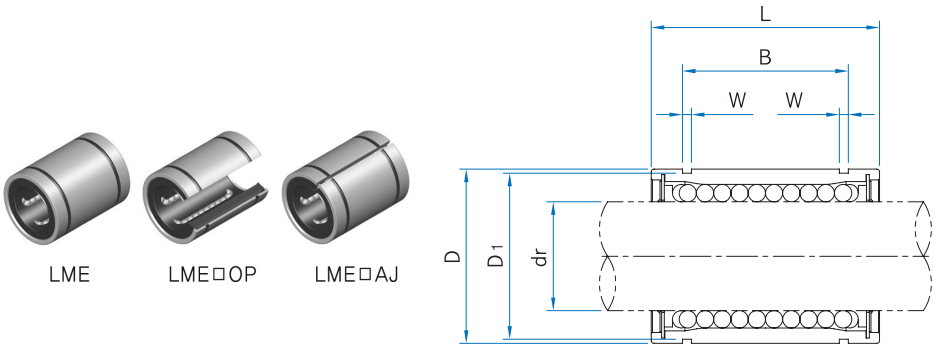

Unit : mm

LM Series						Basic Load Ratings		Working Bore Diameter	
Standard type		Open type(OP)		Adjustable type(AJ)		Dyn C (N)	Stat. Co (N)	dr (mm)	Tol. (μm)
Part No.	No. of Ball circuit	Part No.	No. of Ball circuit	Part No.	No. of Ball circuit				
LME5UU	4	-	-	LME 5UUAJ	4	200	260	5	+8 0
LME8UU	4	-	-	LME 8UUAJ	4	260	400	8	
LME12UU	4	LME12UUOP	3	LME12UUAJ	4	410	590	12	
LME16UU	5	LME16UUOP	4	LME16UUAJ	5	770	1170	16	+9 -1
LME20UU	5	LME20UUOP	4	LME20UUAJ	5	860	1370	20	+11 -1
LME25UU	6	LME25UUOP	5	LME25UUAJ	6	980	1560	25	
LME30UU	6	LME30UUOP	5	LME30UUAJ	6	1560	2740	30	
LME40UU	6	LME40UUOP	5	LME40UUAJ	6	2150	4010	40	+13 -2
LME50UU	6	LME50UUOP	5	LME50UUAJ	6	3280	7930	50	
LME60UU	6	LME60UUOP	5	LME60UUAJ	6	4700	9990	60	

1N ≙ 0.102kgf

Note) Plating and Raydent treatment are available

Reference of dynamic load rating

Dynamic load rating is based on the nominal life of 50km.

In case of 100km, C on the table needs to be divided by 1.26

ex) LME 20 C : 860 N C₁₀₀ : 682 N

$$L = \left(\frac{C}{P}\right)^3 \times 50 \text{ km}, L = \left(\frac{C_{100}}{P}\right)^3 \times 100 \text{ km},$$

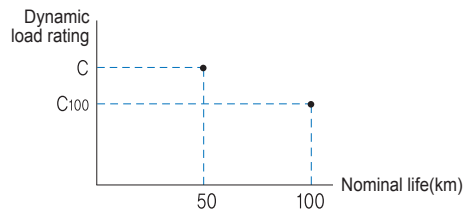

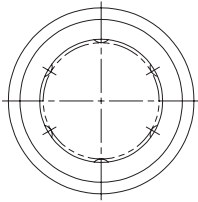

LME

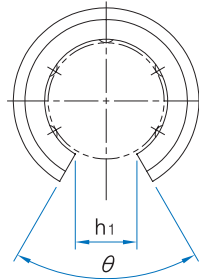

LME□OP

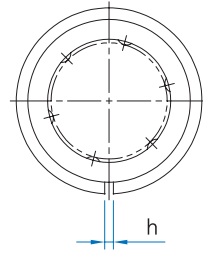

LME□AJ

Unit : mm

D		L		B		Dimensions (mm)					Wgt. (gf)	Allowable Diametral Clearance (μ m)	Part No.
(mm)	Tol. (μ m)	(mm)	Tol. (mm)	(mm)	Tol. (mm)	W	D ₁	h	h ₁	θ (°)			
12	0	22	-0.2	14.5	-0.2	1.1	11.5	1	-	-	12	-5	LME5UU
16	-8	25		16.5		1.1	15.2	1	-	-	20	-5	LME8UU
22	0	32	-0.2	22.9	-0.2	1.3	21	1.5	7.5	78°	41	-7	LME12UU
26	-9	36		24.9		1.3	24.9	1.5	10	78°	57	-7	LME16UU
32	0	45	-0.3	31.5	-0.3	1.6	30.3	2	10	60°	91	-9	LME20UU
40		-11		58		44.1	1.85	37.5	2	12.5	60°	215	-9
47	0	68	-0.3	52.1	-0.3	1.85	44.5	2	12.5	50°	325	-9	LME30UU
62		-13		80		60.6	2.15	59	3	16.8	50°	705	-13
75	-15	100	-0.4	77.6	-0.4	2.65	72	3	21	50°	1130	-13	LME50UU
90		0		125		101.7	3.15	86.5	3	27.2	54°	2220	-16

※ Based on Standard type

1N \approx 0.102kgf

LMF/K/H Series

Flange Type

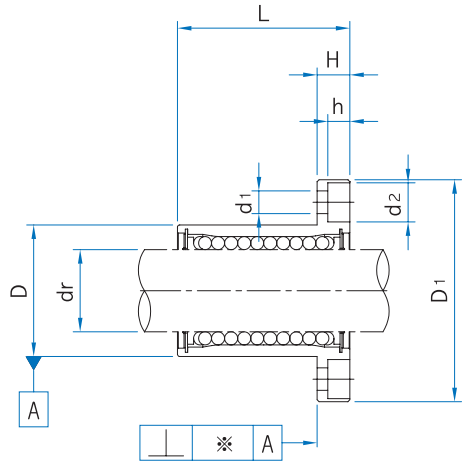

Unit : mm

Part No.		No. of Ball circuit	Wgt.* (gr)	Allowable Diametral Clearance (μm)	Basic Load Ratings		Working Bore Diameter		
Circular type	Square type				Oval type	Dyn. C (N)	Stat. Co (N)	dr (mm)	ToI. (μm)
LMF 6UU	LMK 6UU	-	4	26.5	- 5	200	260	6	0 - 9
LMF 8UU	LMK 8UU	-	4	34.0	- 5	170	220	8	
LMF 8UU	LMK 8UU	-	4	40.0	- 5	260	400	8	
LMF10UU	LMK10UU	LMH10UU	4	78.0	- 5	370	540	10	
LMF12UU	LMK12UU	LMH12UU	4	76.0	- 5	410	590	12	
LMF13UU	LMK13UU	LMH13UU	4	94.0	- 7	500	770	13	
LMF16UU	LMK16UU	LMH16UU	5	134.0	- 7	770	1170	16	0 -10
LMF20UU	LMK20UU	LMH20UU	5	180.0	- 9	860	1370	20	
LMF25UU	LMK25UU	LMH25UU	6	340.0	- 9	980	1560	25	
LMF30UU	LMK30UU	LMH30UU	6	460.0	- 9	1560	2740	30	0 -12
LMF35UU	LMK35UU	-	6	795.0	-13	1660	3130	35	
LMF40UU	LMK40UU	-	6	1054.0	-13	2150	4010	40	0 -15
LMF50UU	LMK50UU	-	6	2200.0	-13	3820	7930	50	
LMF60UU	LMK60UU	-	6	2960.0	-16	4700	9990	60	

Note) Plating and Raydent treatment are available

* The value of Circular type

1N ≒ 0.102kgf

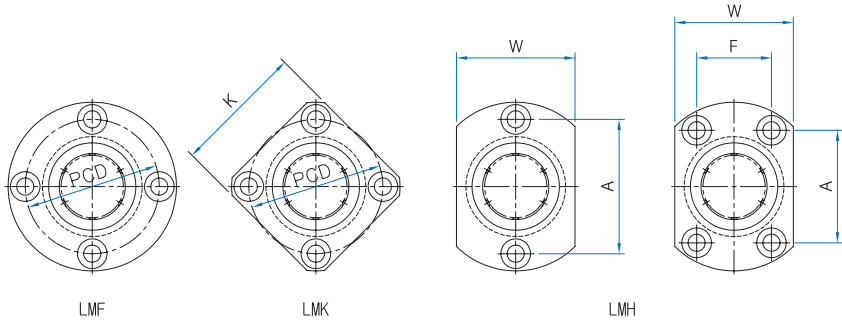

Unit : mm

Dimensions (mm)													Part No.		
D	Tol.	L	Tol.	D ₁	Tol.	H	PCD	K	W	A	F	※		d ₁ x d ₂ x h	
(mm)	(μ m)	(mm)	(mm)	(mm)	(mm)							(μ m)			
12	0	19	0	28	-0.2	5	20	22	-	-	-	12	3,4×6,5×3,3	LMF/K/H6UU	
15	-11	17		32		5	24	25	-	-	-	-	12	3,4×6,5×3,3	LMF/K/H8SUU
15		24		32		5	24	25	-	-	-	-	12	3,4×6,5×3,3	LMF/K/H8UU
19		29		40		6	29	30	25	29	-	-	12	4,5×8×4,4	LMF/K/H10UU
21	0	30	-0.2	42	0	6	32	32	27	32	-	12	4,5×8×4,4	LMF/K/H12UU	
23	-13	32		43		6	33	34	29	33	-	12	4,5×8×4,4	LMF/K/H13UU	
28		37		48		6	38	37	34	31	22	12	4,5×8×4,4	LMF/K/H16UU	
32		42		54		8	43	42	38	36	24	15	5,5×9,5×5,4	LMF/K/H20UU	
40	0	59	0	62	-0.3	8	51	50	46	40	32	15	5,5×9,5×5,4	LMF/K/H25UU	
45	-16	64		74		10	60	58	51	49	35	15	6,6×11×6,5	LMF/K/H30UU	
52		70		82		10	67	64	-	-	-	20	6,6×11×6,5	LMF/K/H35UU	
60	0	80		96		13	78	75	-	-	-	20	9×14×8,6	LMF/K/H40UU	
80	-19	100	-0.3	116	0	13	98	92	-	-	-	20	9×14×8,6	LMF/K/H50UU	
90	-22	110		134		18	112	106	-	-	-	25	11×17,5×10,8	LMF/K/H60UU	

1N \approx 0.102kgf

LMF/K□L Series

Flange Type

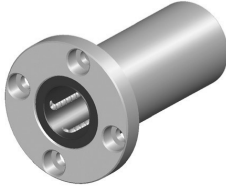

LMF□L

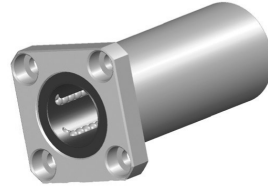

LMK□L

Unit : mm

Part No.		No. of Ball circuit	Wgt.* (gf)	Allowable Diametral Clearance (μm)	Basic Load Ratings		Working Bore Diameter	
Circular type	Square type				Dyn. C (N)	Stat. Co (N)	dr (mm)	Tol. (μm)
LMF6LUU	LMK 6LUU	4	31	-5	320	520	6	0 -10
LMF8SLUU	LMK 8SLUU	4	53	-5	430	780	8	
LMF10LUU	LMK10LUU	4	105	-5	580	1100	10	
LMF12LUU	LMK12LUU	4	100	-5	650	1200	12	
LMF13LUU	LMK13LUU	4	130	-7	810	1570	13	
LMF16LUU	LMK16LUU	5	187	-7	1230	2350	16	0 -12
LMF20LUU	LMK20LUU	5	260	-9	1400	2750	20	
LMF25LUU	LMK25LUU	6	515	-9	1560	3140	25	
LMF30LUU	LMK30LUU	6	655	-9	2490	5490	30	0 -15 0 -20
LMF35LUU	LMK35LUU	6	970	-13	2650	6470	35	
LMF40LUU	LMK40LUU	6	1560	-13	3430	8040	40	
LMF50LUU	LMK50LUU	6	3500	-13	6080	15900	50	
LMF60LUU	LMK60LUU	6	4500	-16	7650	20000	60	

Note) Plating and Raydent treatment are available

1N ≒ 0.102kgf

* The value of Circular type

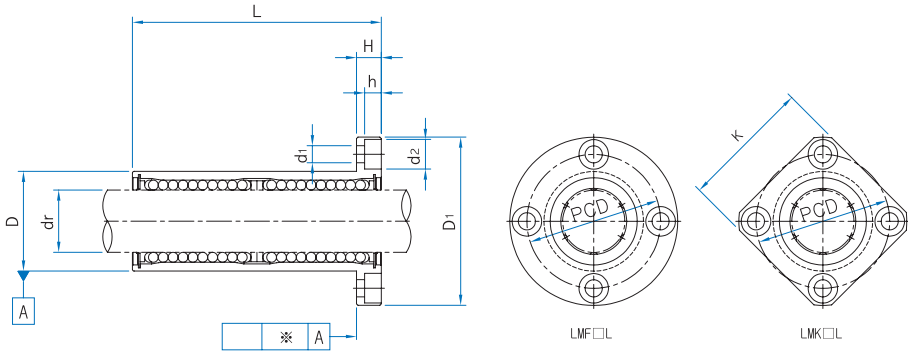

Unit : mm

Dimensions (mm)													Part No.		
D (mm)	Tol. (μ m)	L (mm)	Tol. (mm)	D ₁ (mm)	Tol. (mm)	H	PCD	K	W	A	F	Sqareness * (μ m)		d ₁ x d ₂ x h	
12	0	35	-0.3	28	0	5	20	22	18	20	-	15	3,4×6,5×3,3	LMF6LUU	
15	-13	45		32		5	24	25	21	24	-	15	15	3,4×6,5×3,3	LMF8SLUU
19	0	55		40		6	29	30	25	29	-	15	15	4,5×8×4,4	LMF10LUU
21		57		42		6	32	32	27	32	-	15	15	4,5×8×4,4	LMF12LUU
23	-16	61	0	43	-0.2	6	33	34	29	33	-	15	4,5×8×4,4	LMF13LUU	
28	70	48		6		38	37	34	31	22	15	15	4,5×8×4,4	LMF16LUU	
32	0	80	-0.4	54	0	8	43	42	38	36	24	20	5,5×9,5×5,4	LMF20LUU	
40		112		62		8	51	50	46	40	32	20	20	5,5×9,5×5,4	LMF25LUU
45	-19	123	0	74	-0.3	10	60	58	51	49	35	20	6,6×11×6,5	LMF30LUU	
52		135		82		10	67	64	-	-	-	25	25	6,6×11×6,5	LMF35LUU
60	154	96	0	116	-0.3	13	78	75	-	-	-	25	9×14×8,6	LMF40LUU	
80	192	116		13		98	92	-	-	-	25	25	9×14×8,6	LMF50LUU	
90	-22	211	134	18	112	106	-	-	-	-	25	11×17,5×10,8	LMF60LUU		

1N ≙ 0.102kgf

Linear Ball Bushing

LM□L / LME□L Series

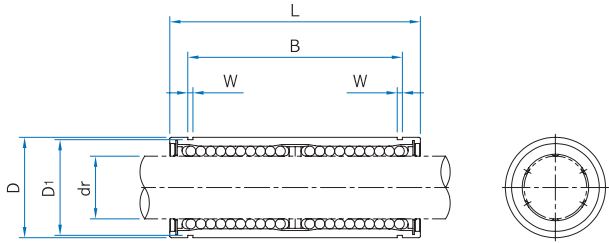

Unit : mm

LM□L Series	Part No.	No. of Ball circuit	Working Bore Diameter		Dimensions (mm)						Basic Load Ratings					
			dr (mm)	Tol. (μm)	D (mm)	Tol. (μm)	L (mm)	Tol. (mm)	B (mm)	Tol. (mm)	W (mm)	D ₁ (mm)	Wgt.* (g)	Dyn. C (N)	Stat. Co (N)	
LM6LUU	4	6	-10	12	0	35	0	27	0	1.1	11.5	16	320	520		
LM8LUU	4	8		15	-13	45		35		1.1	14.3	31	430	780		
LM10LUU	4	10		19	0	55		44		1.3	18	62	580	1100		
LM12LUU	4	12		21	0	57		-0.3		46	-0.3	1.3	20	80	650	1200
LM13LUU	4	13		23	-16	61		46		1.3	22	90	810	1570		
LM16LUU	5	16		28	0	70		53		1.6	27	145	1230	2350		
LM20LUU	5	20	32	0	80	61	1.6	30.5	180	1400	2750					
LM25LUU	6	25	-12	40	-19	112	0	82	0	1.85	38	440	1560	3140		
LM30LUU	6	30	45	0	123	89		1.85		43	580	2490	5490			
LM35LUU	6	35	52	0	135	99		2.1		49	795	2650	6470			
LM40LUU	6	40	-15	60	-22	154		-0.4		121	-0.4	2.1	57	1170	3430	8040
LM50LUU	6	50	80	0	192	148		2.6		76.5	3100	6080	15900			
LM60LUU	6	60	-20	90	-22	211		170		3.15	86.5	3500	7650	20000		
LME□L Series																
LME8LUU	4	8	+9	16	0/-9	45	0	33	0	1.1	15.2	31	430	780		
LME12LUU	4	12	-1	22	0	57		45.8		1.3	21	80	650	1200		
LME16LUU	5	16	+11	26	-11	70		-0.3		49.8	-0.3	1.3	24.9	145	1230	2350
LME20LUU	5	20	-1	32	0	80		61		1.6	30.3	180	1400	2750		
LME25LUU	6	25	+13	40	-13	112		82		1.85	38	440	1560	3140		
LME30LUU	6	30	-2	47	0	123		104.2		1.85	44.5	580	2490	5490		
LME40LUU	6	40	+16 -4	62	0	154	-0.4	121.2	-0.4	2.15	59	1170	3430	8040		
LME50LUU	6	50		75	-15	192	155.2	2.65	72	3100	6080	15900				
LME60LUU	6	60		90	0/-20	211	170	3.15	86.5	3500	7650	20000				

Note) Plating and Raydent treatment are available

1N ≅ 0.102kgf

SC Type

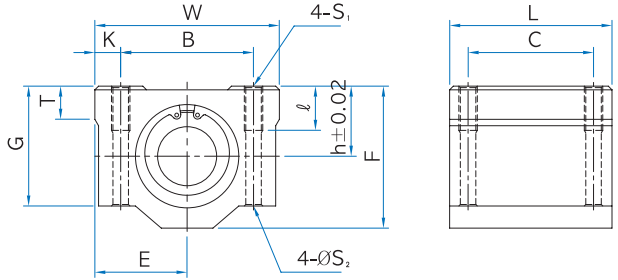
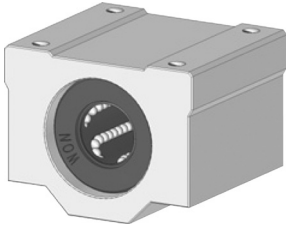

Unit : mm

Part No.	weight (g)	Dimensions							Mounting Dimensions					Shaft d	No. ball rows	Basic Load Ratings	
		h	E	W	L	F	G	T	B	C	K	S ₁	S ₂			dyn C (N)	stat. C ₀ (N)
SC 8UU	52	11	17	34	30	22	18	6	24	18	5	M4	3,4	8	4	260	400
SC 10UU	92	13	20	40	35	26	22	8	28	21	6	M5	4,3	10	4	370	540
SC 12UU	102	15	21	42	36	29	25	8	30.5	26	5,75	M5	4,3	12	4	410	490
SC 13UU	123	15	22	44	39	30	26	8	33	26	5,5	M5	4,3	13	4	500	770
SC 16UU	189	19	25	50	44	38,5	35	9	36	34	7	M5	4,3	16	5	770	1170
SC 20UU	237	21	27	54	50	41	36	11	40	40	7		5,2	20	5	860	1370
SC 25UU	555	26	38	76	67	51,5	41	12	54	50	11	M8	7	25	6	980	1560
SC 30UU	685	30	39	78	72	59,5	49	15	58	58	10	M8	7	30	6	1560	2740
SC 35UU	1100	34	45	90	80	68	54	18	70	60	10	M8	7	35	6	1660	3130
SC 40UU	1600	40	51	102	90	78	62	20	80	60	11	M10	8,7	40	6	2150	4010
SC 50UU	3350	52	61	122	110	102	80	24	100	80	11	M10	8,7	50	6	3820	7930

Note. 1) LM □□UU is in the block.
 2) marked as SH □□UU in the side of block

1N ≒0,102kgf

SCWN Type

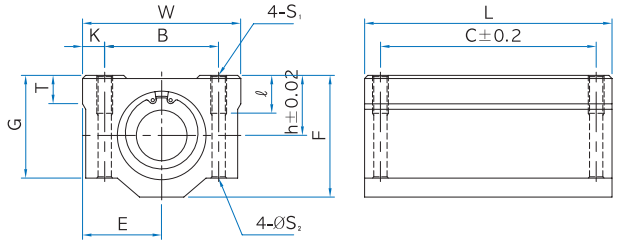
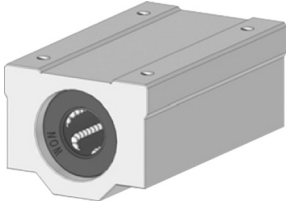

Unit : mm

Part No.	Dimensions							Mounting Dimensions					Shaft d	No. ball rows	Basic Load Ratings	
	h	E	W	L	F	G	T	B	C	K	S ₁	S ₂			dyn C (N)	stat. C ₀ (N)
SCWN 10UU	13	20	40	68	26	22	8	28	46	6	M5	4.3	10	4	588	1100
SCWN 12UU	15	21	42	70	29	25	8	30.5	50	5.75	M5	4.3	12	4	813	1570
SCWN 13UU	15	22	44	75	30	26	8	33	50	5.5	M5	4.3	13	4	813	1570
SCWN 16UU	19	25	50	85	38.5	35	9	36	60	7	M5	4.3	16	5	1230	2350
SCWN 20UU	21	27	54	96	41	36	11	40	70	7	M6	5.2	20	5	1400	2740
SCWN 25UU	26	38	76	130	51.5	41	12	54	100	11	M8	7	25	6	1560	3140
SCWN 30UU	30	39	78	140	59.5	49	15	58	110	10	M8	7	30	6	2490	5490
SCWN 35UU	34	45	90	155	68	54	18	70	120	10	M8	7	35	6	2650	6270
SCWN 40UU	40	51	102	175	78	62	20	80	140	11	M10	8.7	40	6	3430	8040
SCWN 50UU	50	61	122	215	102	80	24	100	160	11	M10	8.7	50	6	6080	15900

Note. 1) 2pcs of LM □□UU are in the block.

2) marked as SHW □□UU in the side of block.

1N ≒0,102kgf

Linear Motion Shaft

Contents

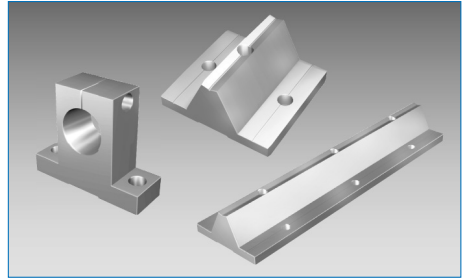

1	LM Shaft	
	1. Type of LM Shaft	240
	2. Materials	241
2	Heat Treatment	241
3	Precision Class	242
4	Equation of Deflection-Angle of LM Shaft	
	1. Case hardened & ground shaft	243
	2. Hollow shaft	243
5	Part Number of LM Shaft	
	1. Type number format I (Case hardened & ground shaft)	244
	2. Type number format II (Hollow shaft)	246
	3. Type number format III(tapped shaft)	247
6	LM Shaft End Support Block & Rail	
	1. Shaft End Support Block	248
	2. Shaft Support Rail	248

1 LM Shaft

1. Type of LM Shaft

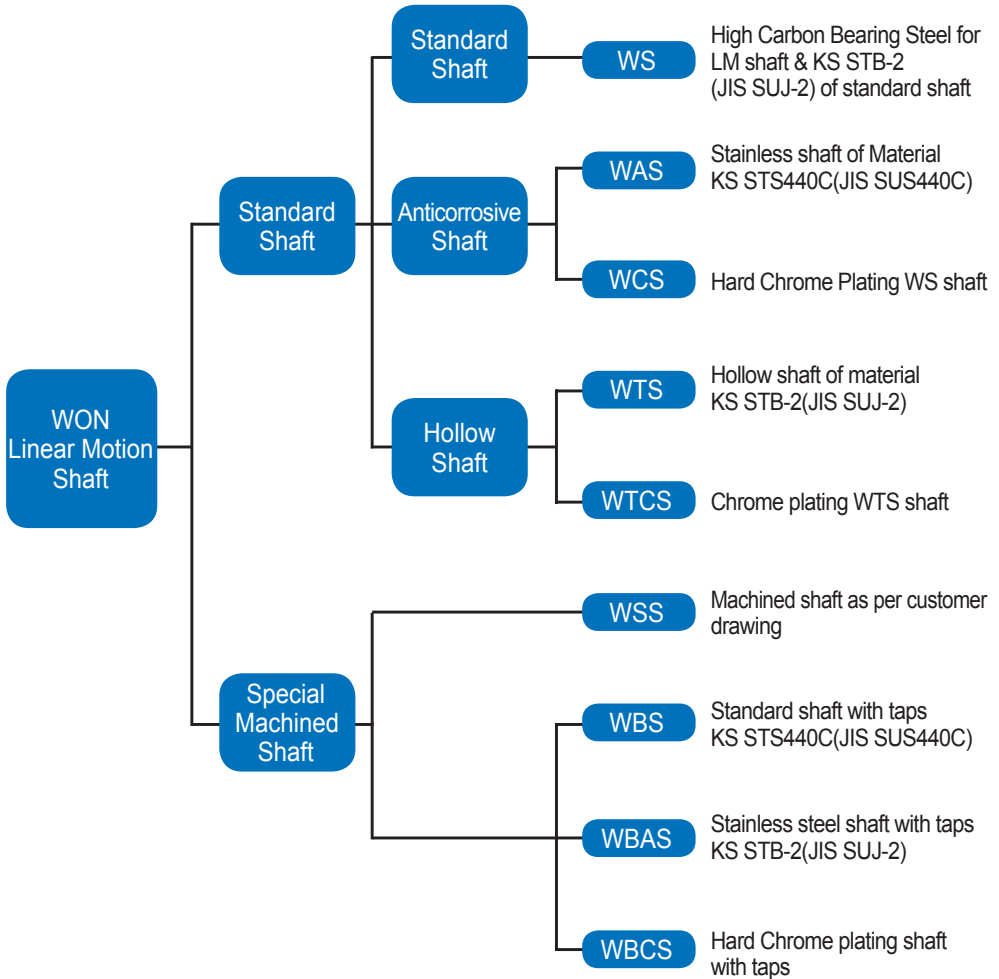

L.M.(Linear Motion) Shaft that WON "WON ST CO., LTD." has been manufacturing is hardened and ground shaft featuring high precision for rectilinear motion which can be used in conjunction with Ball Bushing. LM Shaft used in conjunction with Ball Bushing has a role as the guide of the ball bushing and the inner raceway of the bearing as well. The quality of shaft has a great influence on the functions of ball bushing and linear motion system.

2. Materials

- LM Shaft High Carbon Steel (WON ST Standard Materials)
- High Carbon Chromium Bearing Steel (KS STB-2, JIS SUJ-2)
- Martensite Satinless Steel (KS STS440C, JIS SUS440C)
 In general, "High Carbon Chromium Bearing Steel" is used. For corrosion resistance or non-lubricant application, SUS440C is usually used; Chemistry, Food machinery, Medical instruments, Semiconductor, etc.
- Others(Not for Ball Bushing)
 - KS SMS45C(JIS S45C)
 - KS STS303(JIS SUS303)
 - KS STS304(JIS SUS304)
 - KS STS316(JIS SUS316)

2 Heat Treatment

WON ST CO., LTD. applies the stable and reliable heat treatment technology to LM Shaft using high frequency induction by our own exclusive equipment for the heat treatment. The heat treatment by tempering assures the LM Shafts have uniform hardness in both radial and axial directions, developing an appropriate hardened layer.

1. Surface Hardness

- KS STB-2(JIS SUJ-2).....HRC50 more~
- KS STS440C(JIS SUS440C)..... ϕ 16mm more HRC56 ~
 ϕ 13mm less HRC54 ~

Hardness distribution curve ▶
(ϕ 20)

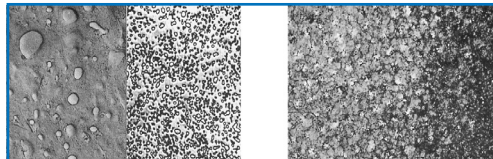
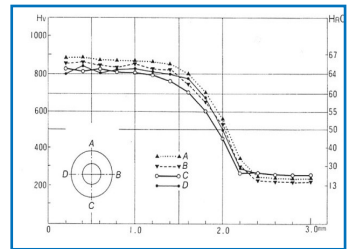

Spheroidizing Organizatron
 The cross-section of high frequency induction heat treatment

Fig 1. Organization photographs

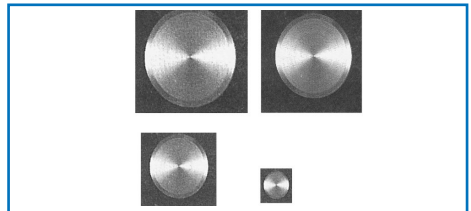
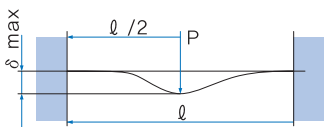
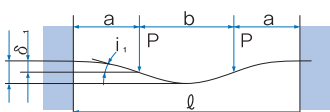
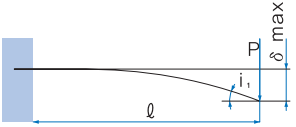

Fig 2. Photograph of Effective hardened layer

3 Precision Class

Diameter tolerance	Surface finish	Straightness
g6, h6, h5(mainly)	Rmax less 1.5 μ m	20 μ m / 300 mm less

4 Equation of Deflection-Angle of LM Shaft

Supporting method	Specified Conditions	Deflection equation	Deflection angle equation
Both ends fixing		$\delta_{\max} = \frac{P\ell^3}{192EI} = \frac{1}{4} \times P\ell^3 C$	$i_1 = 0$ $i_2 = 0$
Both ends fixing		$\delta_1 = \frac{Pa^3}{6EI} \left(2 - \frac{3a}{\ell}\right) = 8Pa^2 \left(2 \frac{3a}{\ell}\right) C$ $\delta_{\max} = \frac{Pa^3}{24EI} \left(2 + \frac{3b}{a}\right) = 2Pa^2 \left(2 + \frac{3b}{a}\right) C$	$i_1 = \frac{Pa^2 b}{2EI \cdot \ell} = \frac{24Pa^2 bc}{\ell}$ $i_2 = 0$
One ends fixing		$\delta_{\max} = \frac{P\ell^3}{3EI} = 16P\ell^3 C$	$i_1 = \frac{P\ell^2}{2EI} = 24P\ell^2 C$ $i_2 = 0$

δ_1 : Deflection at loaded point (mm)
 i_2 : Deflection angle at supporting point
 I : Geometrical moment of inertia(mm⁴)
 a, b : Loading point distance
 P : Concentrated load(N)

δ_{\max} : Maximum deflection(mm)
 E : Modulus of elasticity 2.06×10^5 N/mm²
 i_1 : Deflection angle at loading point
 ℓ : Span(mm)
 C : $1/48EI(1/N \cdot \text{mm}^2)$

1. Case hardened & ground shaft

$$\text{Geometrical moment of inertia } (I) = \frac{\pi D^4}{64} \text{ (mm}^4\text{)}$$

$$D = \text{Diameter (mm)}$$

The geometrical moment of inertia and the value of $C(=1/48EI)$ of each shaft as below.

DIA. meter	Geometrical moment of inertia I (mm ⁴)	$C=1/48EI$ (1/N·mm ²)
3	3.98	2.49×10^{-8}
4	1.26×10	7.87×10^{-9}
5	3.07×10	3.23×10^{-9}
6	6.36×10	1.56×10^{-9}
8	2.01×10^2	4.94×10^{-10}
10	4.91×10^2	2.02×10^{-10}
12	1.02×10^3	9.73×10^{-11}
13	1.40×10^3	7.09×10^{-11}
15	2.49×10^3	3.98×10^{-11}
16	3.22×10^3	3.08×10^{-11}
20	7.85×10^3	1.26×10^{-11}
25	1.92×10^4	5.17×10^{-12}
30	3.98×10^4	2.49×10^{-13}
35	7.37×10^4	1.35×10^{-13}
40	1.26×10^5	7.87×10^{-13}
50	3.07×10^5	3.23×10^{-13}
60	6.36×10^5	1.56×10^{-13}
80	2.01×10^6	4.94×10^{-14}
100	4.91×10^6	2.02×10^{-14}
120	1.02×10^7	9.73×10^{-15}
150	2.49×10^7	3.98×10^{-15}

● Example calculation

Obtain the maximum deflection of a shaft with a major diameter 25mm and a span of 430mm when a concentrated load of 80kgf is applied to the center of the shaft. (Ignore the weight of the shaft)

if) When both ends are fixed;
Assign the values to equation
 $P=784(\text{N})$, $l=430(\text{mm})$,
 $C = 5.17 \times 10^{-12}(1/\text{N}\cdot\text{mm}^2)$
in table

$$\delta \max = \frac{1}{4} P l^3 C = 0.08 (\text{mm})$$

2. Hollow shaft

$$(I) = \frac{\pi}{64} \times (d_2^4 - d_1^4) \text{ (mm}^4\text{)}$$

$$d_2 = \text{Outer Dia. (mm)}, \quad d_1 = \text{Inner Dia. (mm)}$$

Outer DIA. d_2 (mm)	Inner DIA. d_1 (mm)	Geometrical moment of inertia I (mm ⁴)	$C=1 / 48EI$ (1/N·mm ²)
10	4	4.78×10^2	2.08×10^{-10}
13	6	1.34×10^3	7.40×10^{-11}
16	8	3.01×10^3	3.30×10^{-11}
20	14	5.97×10^3	1.66×10^{-11}
25	16	1.60×10^4	6.20×10^{-12}
30	17	3.57×10^4	2.78×10^{-12}
35	19	6.73×10^4	1.47×10^{-12}
40	20	1.18×10^5	8.41×10^{-13}
50	25	2.88×10^5	3.44×10^{-13}
60	30	5.96×10^5	1.66×10^{-13}
80	40	1.88×10^6	5.28×10^{-14}
100	50	4.60×10^6	2.16×10^{-14}

● Example calculation

The maximum deflection of a 1800mm length hollow shaft with outside diameter of 50mm and inside diameter of 25mm is...

(Next page)

- if) When both ends are fixed;
 According to condition $P = 100\text{N}$
 $l = 1800(\text{mm})$
 $C = 3.44 \times 10^{-13} (1/\text{N} \cdot \text{mm}^2)$
 from the table, Therefore

$$\delta \max = \frac{1}{4} P l^3 C = 0.05 (\text{mm})$$

5 Part Number of LM Shaft

1. Type number format I (Case hardened & ground shaft)

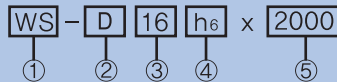

① Type of LM Shaft

Case Hardened and Ground Shaft	WS	Conventional shaft to be used with Ball Bushing. - Material : High Carbon Steel (KS SM55C, JIS S55C) for LM Shaft, KS STB-2(JIS SUJ-2)
	WAS	The exclusive usage for Ball Bushing in use for high anti-corrosive applications under the oxidizing atmosphere such as water, vapor, chemical, food process machinery, semiconductor and medical equipments. - Material : KS STS440C(JIS SUS440C)
	WCS	Hard Chromium plated shaft providing a cost reduction in comparison to the stainless steel shaft with the same function as anti-corrosion. - Material : High Carbon Steel KS SM55C(JIS S55C) for LM Shaft, KS STB-2(JIS SUJ-2)

- ② Machining type and number (In case of standard shaft or simple cutting shaft, This is not necessary to be indicated)

D	Manufacture refer to drawing
---	------------------------------

③Diameter (mm), ④Diameter Tolerance (μm), ⑤Length(mm)

DIA (mm)	Diameter tolerance (μm)			Standard stroked length L (mm)							
	g6	h5	h6	300	500	1000	1200	1500	2000	3000	
3	-2 ~ -8	0 ~ -4	0 ~ -6								
4											
5	-4 ~ -12	0 ~ -5	0 ~ -8								
6											
8	-5 ~ -14	0 ~ -6	0 ~ -9								
10											
12											
13	-6 ~ -17	0 ~ -8	0 ~ -11								
16											
20											
25											
30	-7 ~ -20	0 ~ -9	0 ~ -13								
35											
40											
50	-9 ~ -25	0 ~ -11	0 ~ -16								
60											
80											

Note 1) Max. Length : 6000mm

2) Max. Diameter : \varnothing 300mm

2. Type number format II (Hollow shaft)

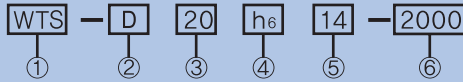

① Type of LM Shaft

Hollow Shaft	WTS	Conventional hollow shaft greatly contributes to reduce weight and simplify equipment due to its hollow structure. Also suitable for electric wiring for measurement, compression air, lubricant hydraulic piping, or robot arm. - Material : High Carbon Steel for LM Shaft, KS STB-2(JIS SUJ-2)
	WTCS	Hard chromium plated hollow shaft used with ball bushing for anti-corrosive applications. - Material : High Carbon Steel for LM Shaft, KS STB-2(JIS SUJ-2)
	WTAS	Stainless steel hollow shaft having the strength of both WTS and WAS. - Material : KS STS440C(JIS SUS440C)

② Machining type and number (In case of standard shaft or simple cutting shaft, This is not necessary to be indicated))

D	Manufacture refer to drawing
---	------------------------------

③ Outer diameter (mm), ④ Diameter Tolerance (μm), ⑤ Inner diameter (mm), ⑥ Length (mm)

Outer Dia. (mm)	Inner Dia. (mm)	Diameter tolerance (μm)			Standard stocked length L (mm)
		g6	h5	h6	
10	4	-5 ~ -14	0 ~ -6	0 ~ -9	1000, 1200, 1500, 2000, 3000
12	6	-6 ~ -17	0 ~ 8	0 ~ -11	
16	8				
20	14				
25	16	-7 ~ -20	0 ~ -9	0 ~ -13	
30	17				
35	19				
40	20	-9 ~ -25	0 ~ -11	0 ~ -16	
50	25				

Note) Manufacturing shafts as per Customer's drawing.

3. Type number format III (Tapped shaft)

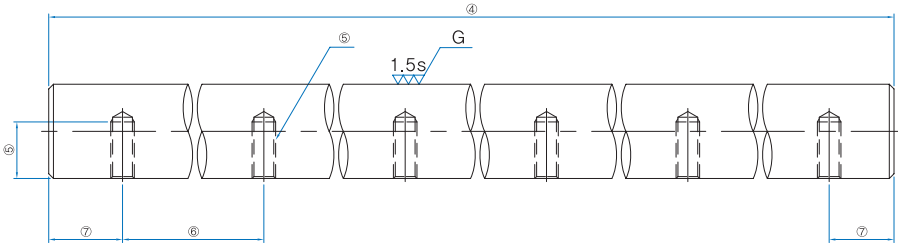
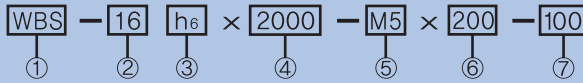

① Type of LM Shaft

Tapped Shaft	WBS	Standard tapped shaft. Material : High Carbon Steel (KS SM55C, JIS S55C) for LM Shaft, KS STB-2(JIS SUJ-2)	We recommend that these shafts should be applied with support rails for shafts and mainly applied in the environment for being occurred deflection or vibration feasibly.
	WBAS	Stainless steel tapped shaft for strong anti-corrosion. Material : KS STS440C(JIS SUS440C)	
	WBCS	Hard chromium plated tapping shaft for anti-corrosion with economical cost in normal use. Material : High Carbon Steel KS SM55C(JIS S55C) for LM Shaft, KS STB-2(JIS SUJ-2)	

Linear Motion Shaft

- ② Diameter (mm), ③ Diameter Tolerance (μm), ④ Length (mm), ⑤ Tap size (mm), ⑥ Pitch(mm), ⑦ Distance from the last taps to The both ends of shaft (mm)

Outer Diameter D(mm)	Diameter tolerance (μm)			Standard length in stock L(mm)					Tap size	Pitch (mm)	Distance from the last taps to both ends (mm)
	g6	h5	h6	1000	1200	1500	2000	3000			
10	-5~-14	0~-6							M4 x 0.7 x 6	100	50
12	-6~-17	0~-8	0~-11						M4 x 0.7 x 6	100	50
13									M4 x 0.7 x 6	100	50

DIA. D(mm)	Diameter tolerance (μm)			Standard length in stock L(mm)					Tap size	Pitch (mm)	Distance from the last taps to both ends (mm)		
	g6	h5	h6	1000	1200	1500	2000	3000					
16	-7~-20	0~-9	0~-13						M5x0,8x9	150	75		
20										M6x1x10	150	75	
25											M6x1x12	200	100
30											M8x1,25x15	200	100
35	-9~-25	0~-11	0~-16						M8x1,25x15	200	100		
40										M8x1,25x18	300	150	
50										M10x1,5x22	300	150	

Note) Max. Lengths : DIA. 10 ~ 12mm : L.4000mm
 DIA. 25mm ~ : L.6000mm

6 LM Shaft End Support Block & Rail

1. Shaft End Support Block

These support blocks can support the ends of LM. Shaft without special machining.
 There are blocks for a plane and a wall.

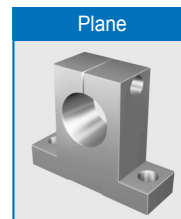

2. Shaft Support Rail

This support rail supports the tapping machined shaft in considering shaft deflection or vibration and makes 'Slide Rail Unit' by being assembled with open type of ball bushing.



Shaft Support Rail I
(ST)

Shaft Support Rail II
(STU)

WK type

Shaft Support End Block for a Plane

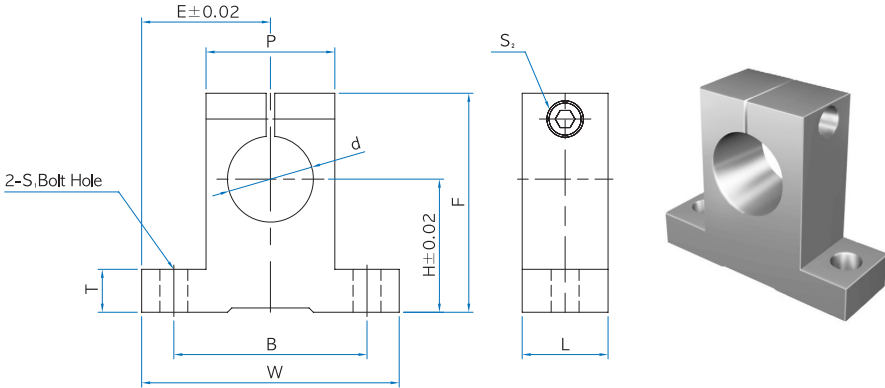

Unit : mm

Part No.	Shaft d	Dimensions								Tightening up Bolt S ₁	Holding down Bolt S ₂
		H	E	W	L	F	T	P	B		
WK 10	Φ10	20	21	42	14	32,8	6	18	32	M5	M4
WK 12	Φ12	23	21	42	14	38	6	20	32	M5	M4
WK 13	Φ13	23	21	42	14	38	6	20	32	M5	M4
WK 16	Φ16	27	24	48	16	44	8	25	38	M5	M4
WK 20	Φ20	31	30	60	20	51	10	30	45	M6	M5
WK 25	Φ25	35	35	70	24	60	12	38	56	M6	M6
WK 30	Φ30	42	42	84	28	70	12	44	64	M8	M6
WK 35	Φ35	50	49	98	32	82	15	50	74	M10	M8
WK 40	Φ40	60	57	114	36	96	15	60	90	M10	M8

- Material : Alumium A 6061

S-ST type

Shaft Support Rail I

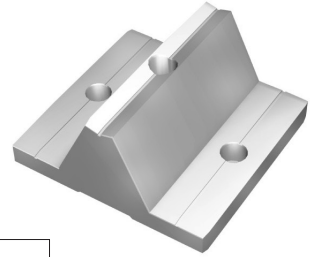
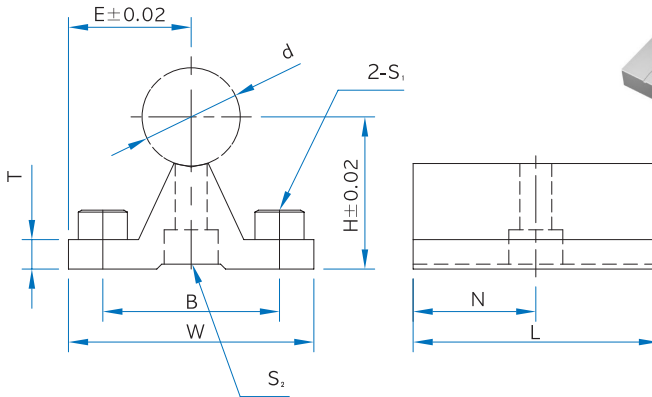

Unit : mm

Part No.	Shaft d	Dimensions					Mounting Dimensions			
		H	E	W	L	T	B	N	S_1	S_2
S-ST16×50	$\Phi 16$	25	20	40	50	5	30	25	M5	M5
S-ST20×50	$\Phi 20$	27	22,5	45	50	5	30	25	M5	M6
S-ST25×50	$\Phi 25$	33	27,5	55	50	6	35	25	M6	M6
S-ST30×60	$\Phi 30$	37	30	60	60	7	40	30	M6	M8
S-ST40×70	$\Phi 40$	48	37,5	75	70	10	55	35	M8	M8

ST type

Shaft Support Rail I

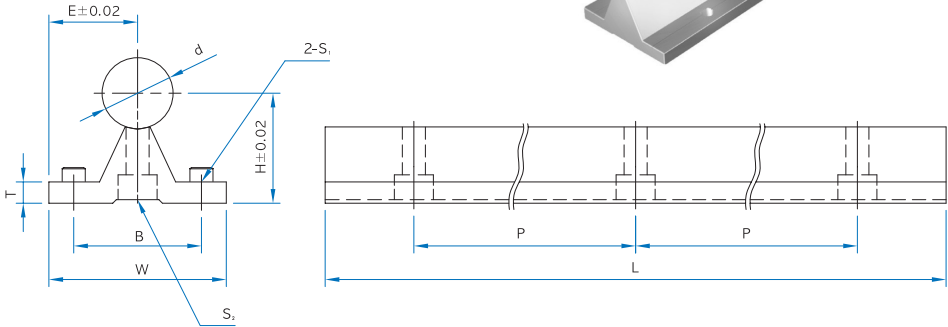

Unit : mm

Part No.	Shaft d	Dimensions					Mounting Dimensions				
		H	E	W	L	T	B	P^*	S_1	S_2	
ST 16	$\Phi 16$	25	20	40	Max length 3m Effective for long stroke application	5	30	150	M5	M5	
ST 20	$\Phi 20$	27	22.5	45		5	30	150	M5	M6	
ST 25	$\Phi 25$	33	27.5	55		6	35	200	M6	M6	
ST 30	$\Phi 30$	37	30	60		7	40	200	M6	M8	
ST 40	$\Phi 40$	48	37.5	75		10	55	300	M8	M8	

Note) P can be changed for customer requirement

S-STU type

Shaft Support Rail II

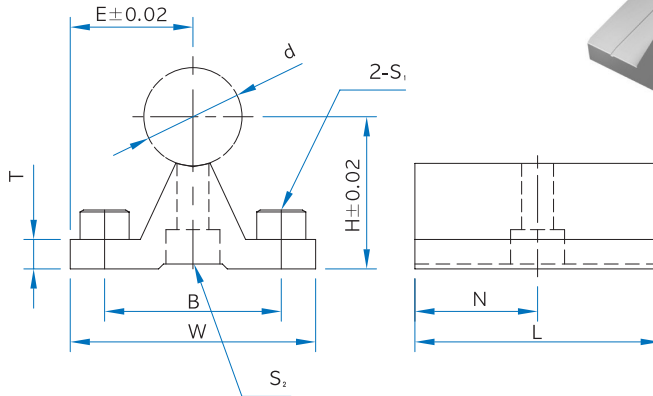

Unit : mm

Part No.	Shaft d	Dimensions					Mounting Dimensions			
		H	E	W	L	T	B	N	S ₁	S ₂
S-STU16×50	∅16	27	21	42	50	6	31	25	M5	M5
S-STU20×50	∅20	31	25	50	50	6	36	25	M6	M6
S-STU25×50	∅25	36	26.5	53	50	7	39	25	M6	M6
S-STU30×60	∅30	43	33.5	67	60	8	49	30	M8	M8
S-STU40×70	∅40	55	37	74	70	11	56	35	M8	M8

STU type

Shaft Support Rail II

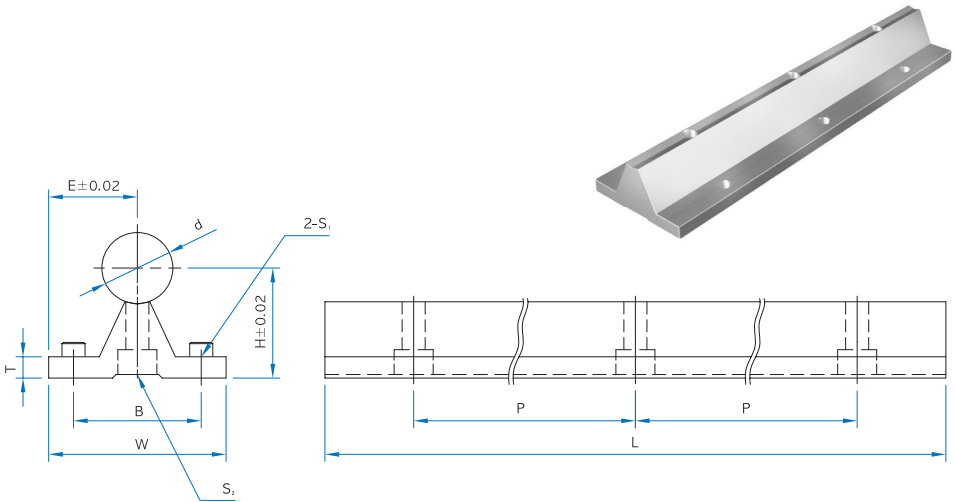

Part No.	Shaft d	Dimensions					Mounting Dimensions				
		H	E	W	L	T	B	P*	S ₁	S ₂	
STU16	φ16	27	21	42	Max length 3m · Effective for long stroke application	6	31	150	M5	M5	
STU20	φ20	31	25	50		6	36	150	M6	M6	
STU25	φ25	36	26,5	53		7	39	200	M6	M6	
STU30	φ30	43	33,5	67		8	49	200	M8	M8	
STU40	φ40	55	37	74		11	56	300	M8	M8	

Note) P can be changed for customer requirement

Slide Rail unit

Slide Rail Unit is consist of open type Block and Shaft with taps and Shaft support rail

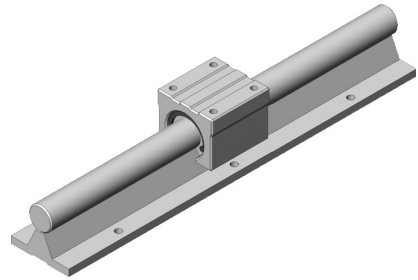
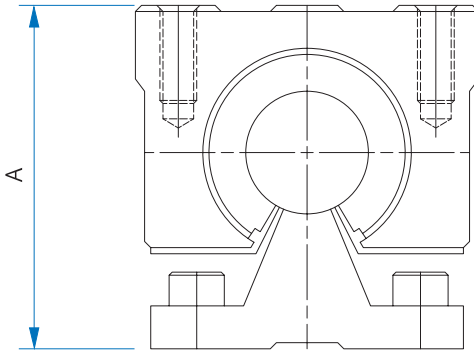

- Assembly hight. A

Shaft	Shaft support rail		S-ST ST	S-STU STU
	Open type			
16	SHO 16 UU		45	47
	CSO 16 UU			
20	SHO 20 UU		50	54
	CSO 20 UU			
25	SHO 25 UU		60	63
	CSO 25 UU			
30	SHO 30 UU		70	76
	CSO 30 UU			
40	SHO 40 UU		90	97
	CSO 40 UU			

Track Roller Guide

Contents

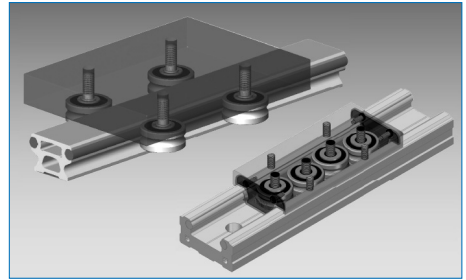

<p>1 T.R Guide</p> <p>1. Structure & Features 256</p> <p>2. Speed and Noise 257</p> <p>3. Adjustable Clearance..... 257</p> <p>4. Load Capacity in any direction 257</p> <p>5. Perfect Sealing and Lubrication..... 257</p> <p>6. Available Temperature 257</p> <p>7. Easy Installation 257</p>	<p>6 End Seal(T type)..... 264</p>
<p>2 Guide Rail Series</p> <p>1. Outside Type 258</p> <p>2. Inside Type 259</p>	<p>7 Cap Seal 264</p>
<p>3 Types of Block</p> <p>1. Outside Type 260</p> <p>2. Inside Type 261</p>	<p>8 Cap Seal Assembly 264</p>
<p>4 Assembly and Adjustment</p> <p>1. Outside Type 262</p> <p>2. Inside Type 263</p>	<p>9 Accuracy..... 265</p>
<p>5 Track Roller 264</p>	<p>10 Service Life</p> <p>1. Basic Dynamic Load Ratings C (Basic Dynamic Moment M)..... 266</p> <p>2. Basic Static Load Ratings Co (Basic Static Moment Mo) 266</p> <p>3. Maximum allowable load..... 266</p> <p>4. Service Life depending loads in any direction..... 266</p> <p>5. Service Life depending moment in any direction..... 266</p>

1 T.R Guide

1. Structure & Features

Outside Type

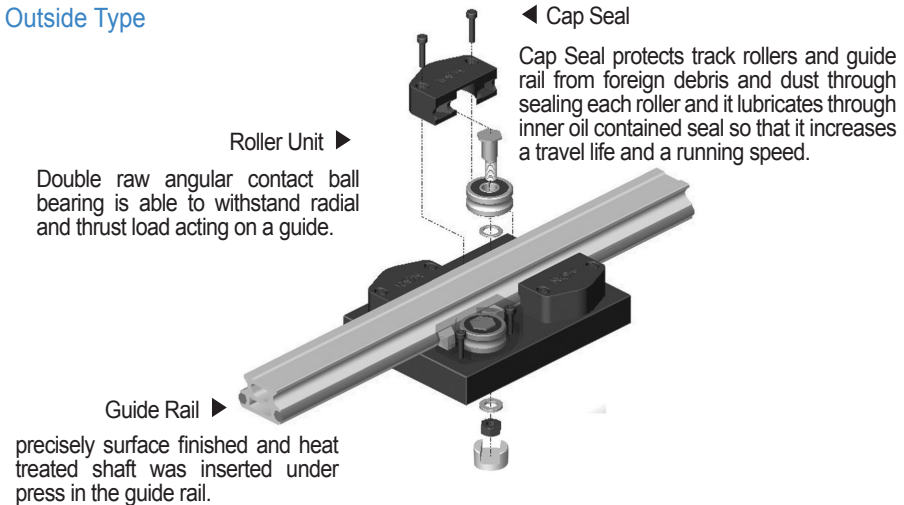

Inside Type

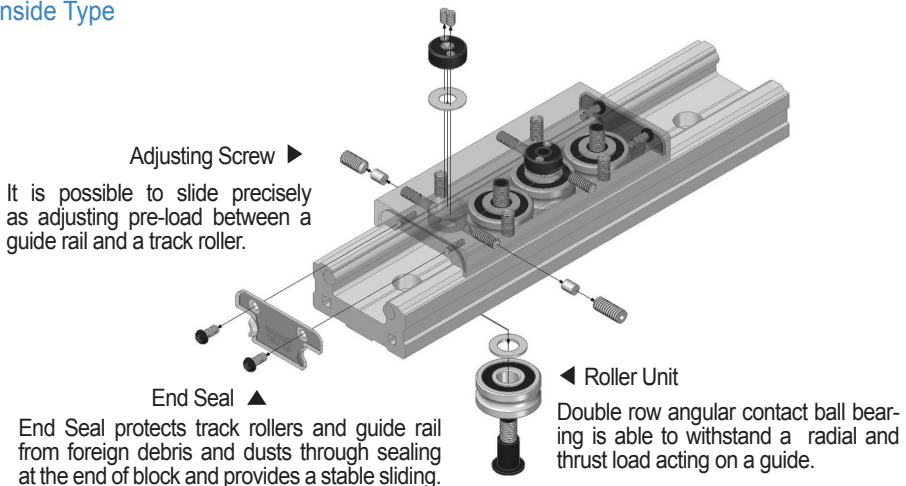

WON Track Roller Guide has been developed by WON R&D Center based on knowledge and experience for several years in the field of Linear Motion System. It consists of the guide rail inserted by applying pressure onto a precisely grinded and heat treated (HRC 62) shaft and a roller unit.

2. Speed and Noise

Conventional Linear Motion Guide uses balls inside a sliding block and a series of balls recirculate in sliding block. That is why makes a noise, vibration and low speed. In case of Track Roller Guide(T.R Guide), it applies several roll bearings instead of a series of balls so that it is possible to reduce noise and vibration at the maximum rotational speed as follows.

- Maximum Speed $V_{max} = 10 \text{ m/s}$
- Maximum Acceleration $A_{max} = 50 \text{ m/s}^2$

3. Adjustable Clearance

When preloads and backlashes are required between a guide rail and a track roller, it is feasible to adjust a clearance by using an adjustable eccentric screw.

4. Load Capacity in any direction

Track Roller is double row angular contact ball bearing so it can withstand loads in any direction.

5. Perfect Sealing and Lubrication

Cap Seal protects track rollers and a guide rail from foreign debris and dusts through sealing each roller and it provides lubrication into TR Guide through an inner oil contained seal.

6. Available Temperature

-20°C~80°C

7. Easy Installation

It is easy to install and handle due to light weight and compact structure. Because it provides a high speed sliding, a high precision and a compact structure, it is so easy to install and maintain that this is a very economical Linear Motion System.

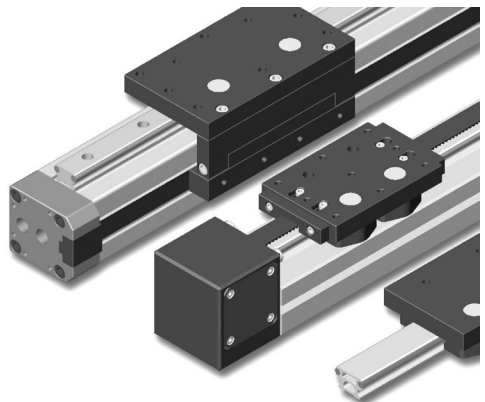

2 Guide Rail Series

1. Outside Type

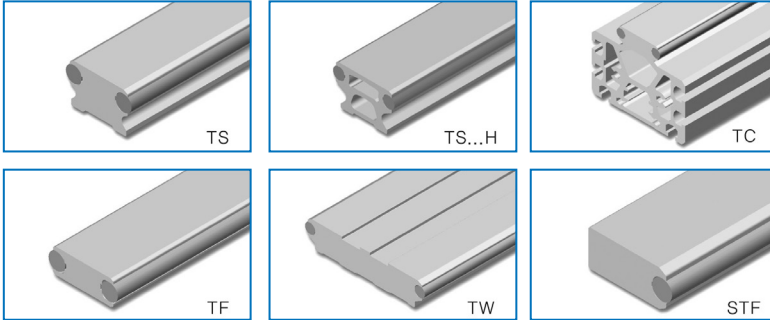

Standard Length & Maximum Length

The table below shows the standard lengths and the maximum lengths of a guide rail. If the maximum length of a needed guide rail exceeds them, jointed rails will be used. When a special length is required, Please contact us.



Unit : mm

Part No.	20	25	32	42	52	TW52
Standard Length of Guide Rail (Lo)	300	300	550	675	800	675
	550	550	800	925	1050	925
	800	800	1050	1175	1300	1175
	1050	1050	1300	1425	1550	1425
	1300	1300	1550	1675	1800	1675
	1550	1550	1800	1925	2050	1925
	1800	1800	2050	2175	2300	2175
	2300	2300	2300	2425	2550	2425
	2800	2800	2550	2675	2800	2675
		2800	2925		2925	
P	62,5	62,5	125	125	250	250
G	25	25	25	25	25	25
Lmax	6000	6000	6000	6000	6000	6000

2. Inside Type

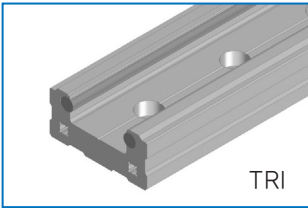

Standard Length & Maximum Length

The table below shows the standard lengths and the maximum lengths of a guide rail. If the maximum length of a needed guide rail exceeds them, jointed rails will be used. When a special length is required, Please contact us.

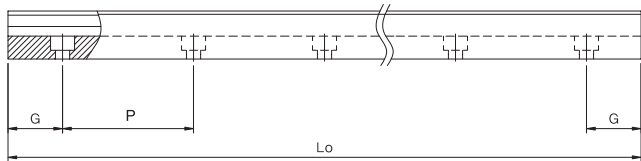
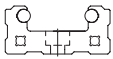

Unit : mm

Part No.	15	20	25	30	35	45	55
Standard Length of Guide Rail (Lo)	160	220	220	280	280	570	780
	400	400	400	520	520	990	1020
	700	700	700	600	600	1200	1500
	1000	1000	1000	1000	1000	1515	1980
	1300	1300	1300	1400	1400	2040	2460
	1600	1600	1600	1480	1480	2460	2700
	1900	1900	1900	1800	1800	2985	3060
	2200	2200	2200	2040	2040	3300	3300
	2500	2500	2500	2200	2200	3510	3540
	2800	2800	2800	2520	2520	4035	3900
	3100	3100	3100	2600	2600	4455	4020
	3400	3400	3400	3000	3000		4500
	3700	3700	3700	3400	3400		
	4000	4000	4000	3800	3800		
	4300	4300	4300	4600	4600		
P	60	60	60	80	80	105	120
G	20	20	20	20	20	22,5	30
Lmax	6000	6000	6000	6000	6000	6000	6000

3 Types of Block

1. Outside Type

There are two kinds of blocks : Non-Adjustable Block and Adjustable Block.

- Non-Adjustable Block

Non-Adjustable Block assembled with a precise guide rail at the best fit has a clearance within $20\ \mu\text{m}$ between a rail and a block. It is unnecessary the eccentric screw for adjusting clearance so that it is economical in use.

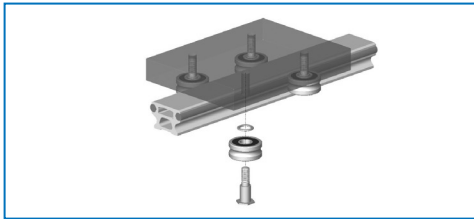
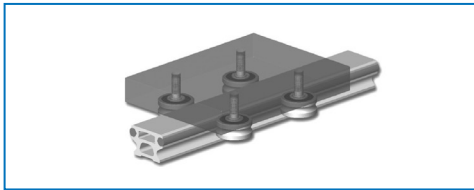

- Clearance Adjustable Block

Clearance Adjustable Block is used for setting Zero clearance or putting preload.

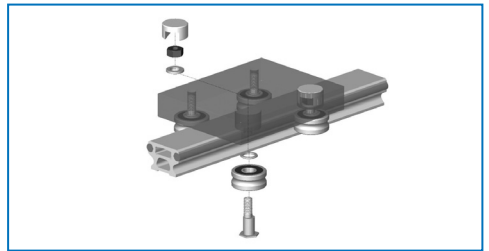
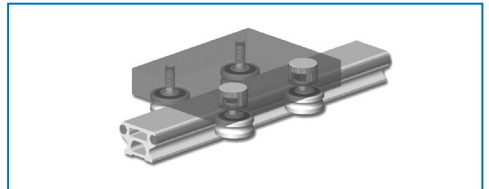

Maximum Allowable Load

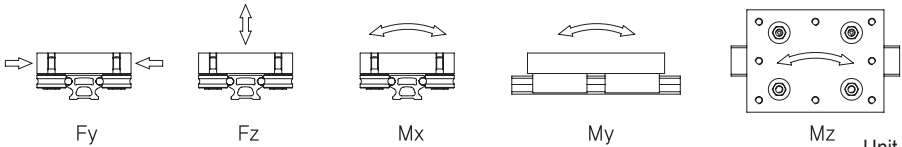

Part No.	$F_{y\max}$ (N)	$F_{o\max}$ (N)	$F_{z\max}$ (N)	$F_{o\max}$ (N)	$M_{x\max}$ (N·m)	$M_{o\max}$ (N·m)	$M_{y\max}$ (N·m)	$M_{o\max}$ (N·m)	$M_{z\max}$ (N·m)	$M_{o\max}$ (N·m)	Unit : mm
20	406	400	238	200	1,9	1,6	5,9	5,0	10,2	10,0	
25	1495	1140	713	560	6,8	5,3	19,6	15,4	41,1	31,4	
32	1495	1140	713	560	9,3	7,3	23,2	18,2	48,6	37,1	
42	3574	2600	1663	1240	26,6	19,8	58,2	43,4	125,1	91,0	
52	3574	2600	1663	1240	34,9	26,0	74,8	55,8	160,8	117,0	

$1\text{N} \cdot \text{m} \approx 0,102\text{kgf} \cdot \text{m}$

※ Service load shall not exceed the maximum allowable load shown in the table of maximum allowable load.(Refer to P272.)

2. Inside Type

There are two kinds of block available for an inside type of TR Guide: Non-Adjustable Block and Adjustable Block.

- Non-Adjustable Block

Non-Adjustable Block assembled with a precise guide rail at the best fit has a clearance within 20 μm between a rail and a block.

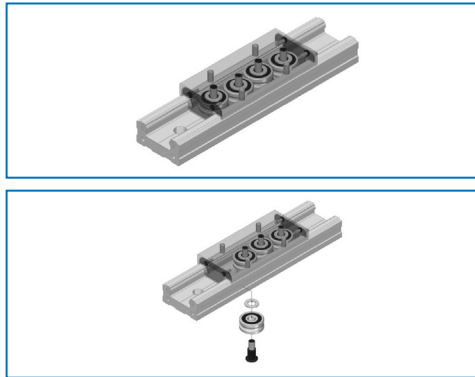

- Clearance Adjustable Block

Clearance Adjustable Block is used for setting Zero clearance or putting preload.

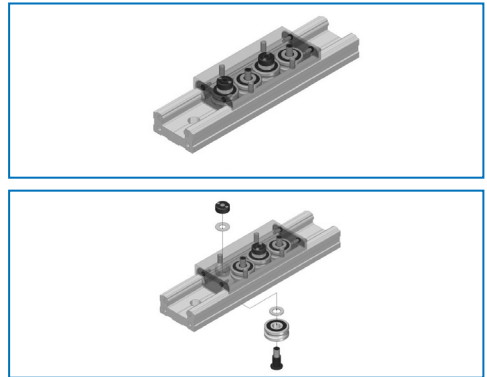

- Maximum Allowable Load

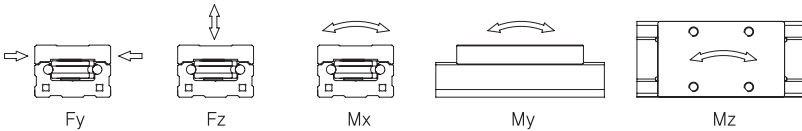

Unit : mm

Part No.	$F_{y\max}$ (N)	$F_{oy\max}$ (N)	$F_{z\max}$ (N)	$F_{oz\max}$ (N)	$M_{x\max}$ (N·m)	$M_{ox\max}$ (N·m)	$M_{y\max}$ (N·m)	$M_{oy\max}$ (N·m)	$M_{z\max}$ (N·m)	$M_{oz\max}$ (N·m)
TRI 15	406	400	194	150	1.8	1.4	3.3	2.6	6.9	6.8
TRI 15L	406	400	238	200	2.3	1.9	6.3	5.3	10.8	10.7
TRI 20	406	400	194	150	2.3	1.8	3.5	2.7	7.3	7.2
TRI 20L	406	400	238	200	2.9	2.4	7.8	6.6	13.4	13.2
TRI 25	1495	1140	583	420	9.0	6.5	14.6	10.5	37.4	28.5
TRI 25L	1495	1140	713	560	11.0	8.7	26.7	21.0	56.0	42.8
TRI 30	1495	1140	583	420	10.5	7.6	15.7	11.3	40.4	30.8
TRI 30L	1495	1140	713	560	12.8	10.1	31.0	24.4	65.0	49.6
TRI 35	3574	2600	1359	930	30.6	20.9	48.9	33.5	128.7	93.6
TRI 35L	3574	2600	1663	1240	37.4	27.9	89.8	67.0	193.0	140.4
TRI 45	3574	2600	1359	930	34.0	23.3	50.3	34.4	132.2	96.2
TRI 45L	3574	2600	1663	1240	41.6	31.0	99.8	74.4	214.4	156.0
TRI 55	3574	2600	1359	930	40.8	27.9	61.2	41.9	160.8	117.0
TRI 55L	3574	2600	1663	1240	49.9	37.2	122.2	91.1	262.7	191.1

1N·m \approx 0.102kgf·m

※ Service load shall not exceed the maximum allowable load shown in the table of maximum allowable load.(Refer to P272.)

4 Assembly and Adjustment

1. Outside Type

WON Track Roller Guide for a clearance adjustable block provides a precise sliding through adjusting a clearance to zero.

- 1) Coaxial bearing being the criteria for an adjustment is completely fastened up but eccentric axial bearing is fasten loosely so that remains enough a gap between a rail and an adjustable block.
- 2) With the state of the block assembled on guide rail, screws should be tighten up equally using a torque wrench until an eccentric axial bearing is contacted with a guide rail properly.
 - A) If the block assembled moves smoothly and each of track rollers rotates, the eccentric axial bearing should be adjusted correctly.
 - B) Please caution that it could shorten a life span of the eccentric axial bearing if the screws were tightened up excessively.
- 3) If the eccentric axial bearing were adjusted exactly, Please fasten lock nuts and bolts referring to recommended torque as below.

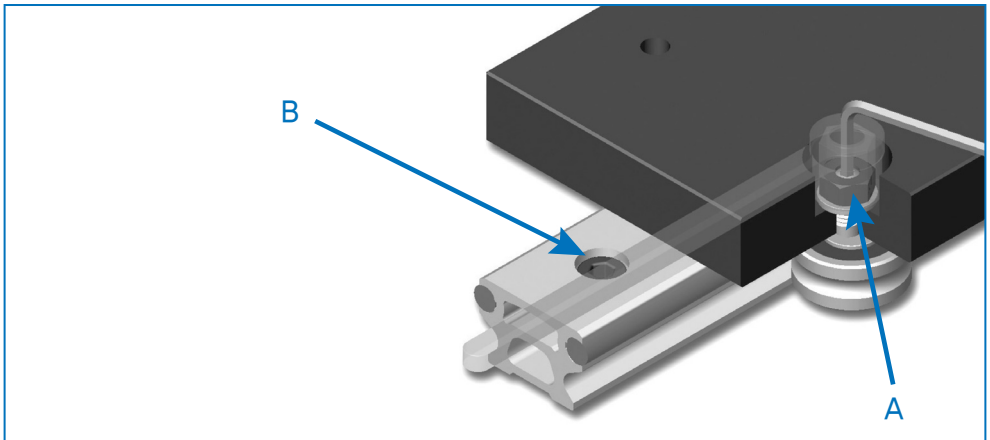

- Roller Assembly Torque(A)

Unit : mm

Part No.	20	25	32	42	52
Max (N·m)	2.0	8.0	8.0	46	46

- Rail Assembly Torque(B)

Part No.	M5	M6	M8	M10	M12
Max (N·m)	5.8	9.9	24	48	80

1N·m \doteq 0.102kgf·m

2. Inside Type

WON Track Roller Guide of an inside type (TRI) for a clearance adjustable block provides a precise sliding through adjusting clearance to zero.

- 1) Non-adjustable bearing being the criteria for an adjustment is completely fastened up but an adjustable bearing is fasten loosely so that remains enough a gap between a rail and an adjustable block.
- 2) With the state of the block assembled on a guide rail, the adjust screws at the side of block should be tighten up equally using a torque wrench until a roller is contacted with a guide rail properly.
 - A) If the block assembled moves smoothly and each of track rollers rotates, the eccentric axial bearing should be adjusted correctly.
 - B) Please caution that it could shorten a life span of LM System if the screws of adjustable bearing were tightened up excessively.
- 4) Please prevent loosening of a bolt as fastening a lock bolt.

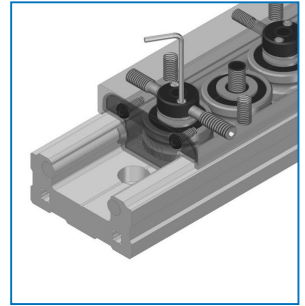
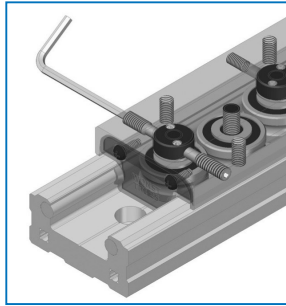
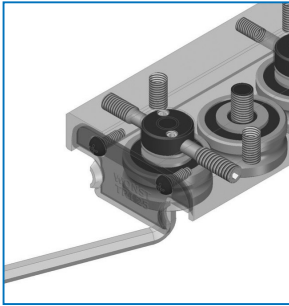

- Roller Assembly Torque

Unit : mm

Part No.	15	20	25	30	35	45	55
Max (N·m)	2.0	2.0	8.0	8.0	46	46	46

- Rail Assembly Torque

Part No.	15(M4)	20(M5)	25(M6)	30(M6)	35(M8)	45(M10)	55(M12)
Max (N·m)	2.5	5.8	9.9	9.9	24	48	80

1N·m ≒ 0.102kgf·m

5 Track Roller

There are two kinds of rollers for a shaft, eccentric and concentric rollers. Track roller is 2 row angular contact ball bearing.

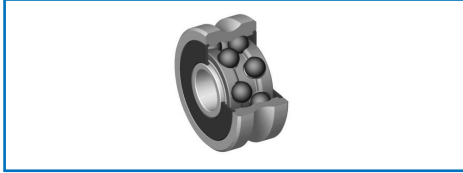

Concentric Roller for Shaft

When it is not necessary to adjust a clearance it is used.

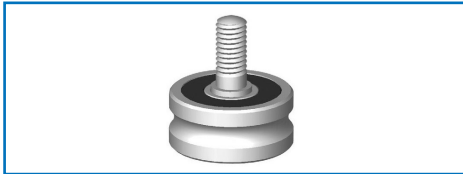

Eccentric Roller for Shaft

When it is necessary to adjust a clearance it is used.



6 End Seal (T type)

Seal in the front and rear of the block protects a Shaft & roller from dusts, and increases the Service Life and stability of movement.

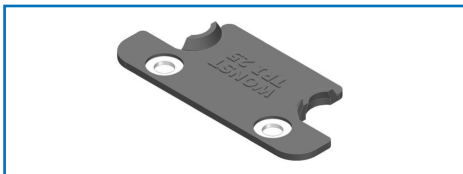

7 Cap Seal

Cap Seal protects shafts and rollers from dusts and stock oil. By doing so, increase a travel life and improves the stability of moving guide at high speed.

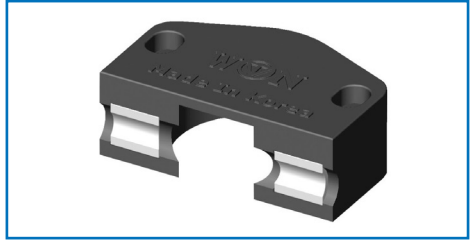

8 Cap Seal Assembly

We recommend that a cap seal should be assembled in the last step after completing the adjustment of rollers. To install a cap seal on the block, 1) Take off block from a guide rail, 2) Assemble a cap seal to block temporary so that secure an enough gap for a cap seal, 3) Assemble a cap seal to a guide rail tighten, 4) Adjust the gap between a cap seal and a block while approaching a cap seal to the surface of a shaft.

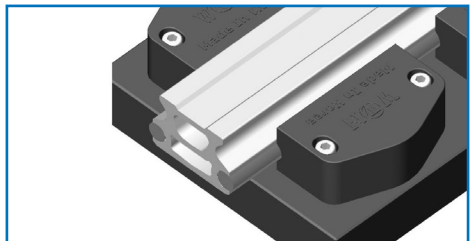

9 Accuracy

Accuracy of T.R Guide is measured as below method.

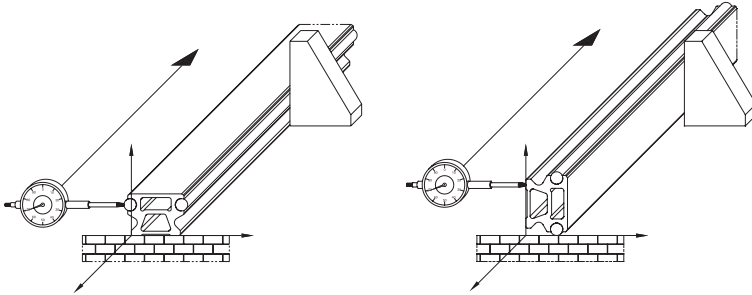

Fig 1. Measurement Method

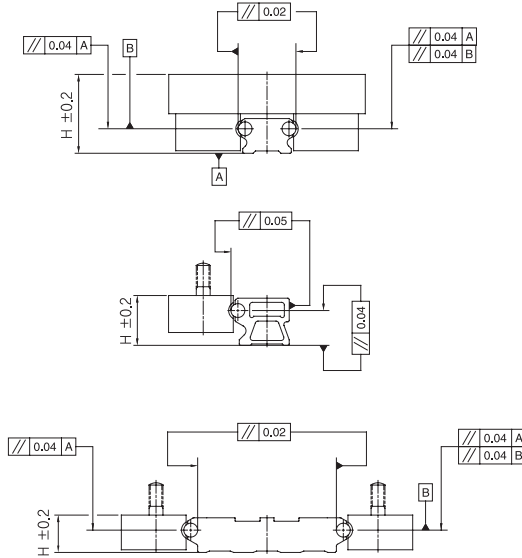

Fig 2. Accuracy

10 Service Life

Service life refers to the total running distance that 90% of identical bearings in a group, when one locked with another internally under the same conditions, can be achieved without developing flaking.

1. Basic Dynamic Load Ratings C (Basic Dynamic Moment M)

When a group of bearing under the same load(Moment) run, if 90% of them are not damaged and run 100Km, the load is called the basic dynamic load (Basic dynamic moment M).

2. Basic Static Load Ratings Co (Basic Static Moment Mo)

Basic Static Load Ratings Co (Basic Static Moment(Mo)) is a stationary force or couple applied to both a raceway and rolling elements as much as 0.001 permanent deformations unchanging in magnitude, points of application, and direction, which the sum of the permanent deformation on the rolling elements and that of the raceway at a contact area under the maximum stress.

3. Maximum allowable load(maximum allowable moment)

Maximum allowable load(maximum allowable moment) is maximum moment which is allowed not only for capability of load carrying of track roller but also for smooth linear motion as considering strength of a rail, block and bolt.

4. Service Life depending loads in any direction

$$L = \left(\frac{C_{yz}}{P} \right)^3 \cdot 10^5$$

$$L_h = \frac{L}{2 \cdot \ell_s \cdot n_1 \cdot 60}$$

L	: Service life	(m)
L _h	: Service life	(h)
C _{yz}	: Basic dynamic load ratings of each direction	(N)
P	: Applied load in each direction	(N)
ℓ _s	: Stroke	(m)
n ₁	: The number of return	(o.p.m.)

※ When applied load is less than maximum allowable load C_{yz}, rating life shall be calculated from the equation above.

5. Service Life depending moment in any direction

$$L = \left(\frac{M_{xyz}}{M} \right)^3 \cdot 10^5$$

$$L_h = \frac{L}{2 \cdot \ell_s \cdot n_1 \cdot 60}$$

L	: Service life	(m)
L _h	: Service life	(h)
M _{xyz}	: Allowable moment in each direction	(N · m)
M	: Applied moment in each direction	(N · m)
ℓ _s	: Stroke	(m)
n ₁	: The number of Cycles	(o.p.m.)

※ When applied moment is less than maximum allowable moment M_{xyz}, rating life shall be calculated from the equation above.

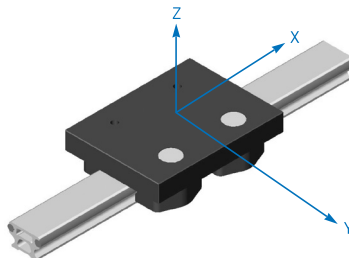

STF type Guide Rail

Examples of model number formation

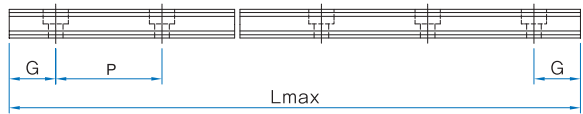
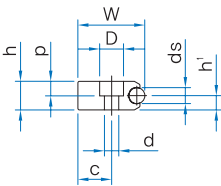
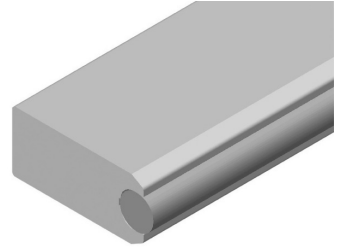
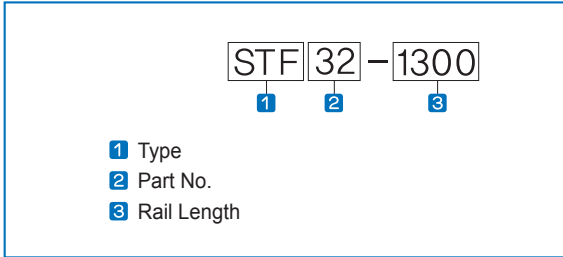

Unit : mm

Part No.	Dimensions		Rail Dimensions						
	W	L (max.)	c	ds	h	hi	d×D×p	G	P
STF 32	26	6000	10	6	10	5	6.5×12×6.5	25	125
STF 52	42	6000	16	10	18	9	11×19×13	25	250

※ Please inquire us for your specially required dimensions & application

TS type

Examples of model number formation

TS | 32H | -2 | BC | S | -1300

1 2 3 4 5 6

- 1 Type 2 Part No.
- 3 Guide Rail Type : Solid(No Symbol), Hollow(H), Block Quantity
- 4 Block Type : Secure Type Block(B), Gap Arbitration Block(BC)
- 5 Capseal : No Sticking(No symbol), Sticking(S)
- 6 Rail Length

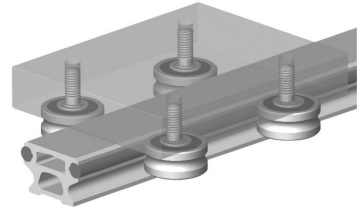

Basic Static Load Ratings and Moment

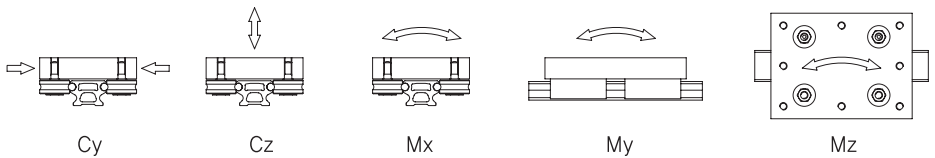

Part No.	Basic load ratings				Permissible Moment					
	Cy (N)	Coy (N)	Cz (N)	Coz (N)	Mx (N·m)	Mox (N·m)	My (N·m)	Moy (N·m)	Mz (N·m)	Moz (N·m)
TS 20	1860	1600	870	760	7,0	6,1	21,8	19,0	46,7	40,0
TS 25	5960	4560	2850	2200	27,1	20,9	78,4	60,5	164,0	125,4
TS 32H	5960	4560	2850	2200	37,1	28,6	92,6	71,5	193,8	148,2
TS 42H	13930	10200	6620	4920	106,0	78,7	231	172	487	357
TS 52H	13930	10200	6620	4920	139,0	103	298	221	627	459

※ Please inquire us for your specially required dimensions & application

※ Rails above TS 32H Size are hollow type.

※ The figure of rating load and moment is for life time calculation and the figure of maximum allowable load could be referred to P260.

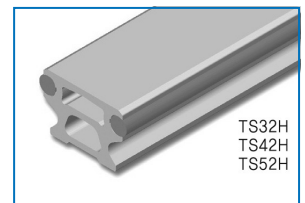
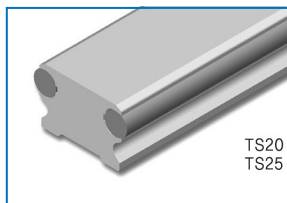

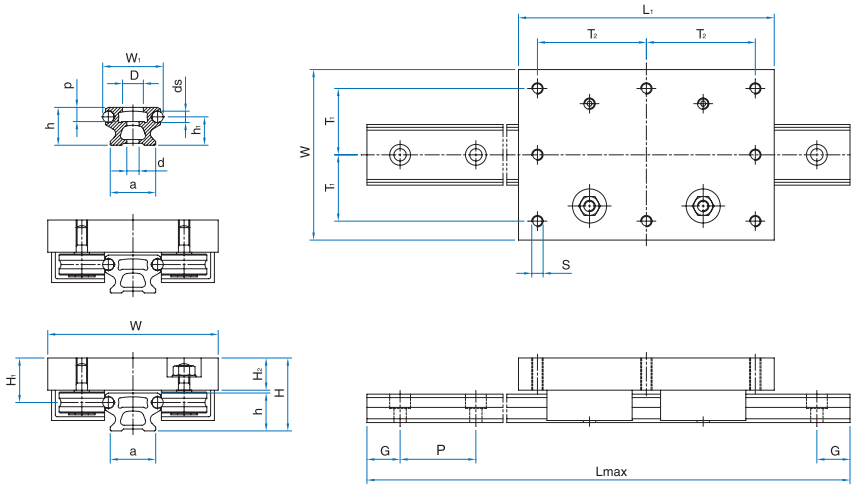

Unit : mm

Part No.	Basic load ratings			Block							Rail						
	W	W ₁	L (max.)	L ₁	H	H ₁	H ₂	S	T ₁	T ₂	a	ds	h	h ₁	d×D×p	G	P
TS 20	60	20	6000	110	25,5	16,5	12,5	M 5	25	50	17	4	12,2	9	4,5×8×4,6	25	62,5
TS 25	85	25	6000	125	34,1	23,5	17	M 6	35	55	21	6	15	10,6	5,5×10×6,5	25	62,5
TS 32H	90	32	6000	145	38,5	23,5	17	M 6	37,5	65	24	6	20	15	6,5×12×7,5	25	125
TS 42H	120	42	6000	170	47,5	34,9	25,2	M 8	50	75	28	10	20	12,6	9×15×8,5	25	125
TS 52H	130	52	6000	205	60	34,9	25,2	M10	52,5	90	40	10	34	25,1	11×19×13	25	250

1N ≙ 0.102kgf
 1N·m ≙ 0.102kgf · m

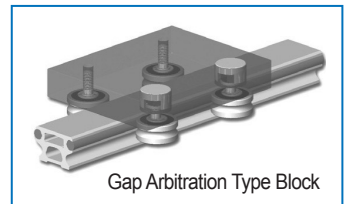
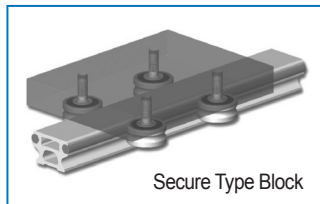

T.R Guide

TC type

Examples of model number formation

TC	25	-	2	BC	S	-	1300
1	2		3	4	5		6

- 1** Type **2** Part No. **3** Block Quantity
4 Block Type : Secure Type Block(B), Gap Arbitration Block(BC)
5 Capseal : No Sticking(No symbol), Sticking(S) **6** Rail Length

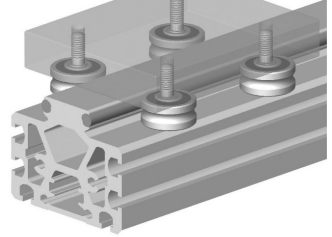

Basic Static Load Ratings and Moment

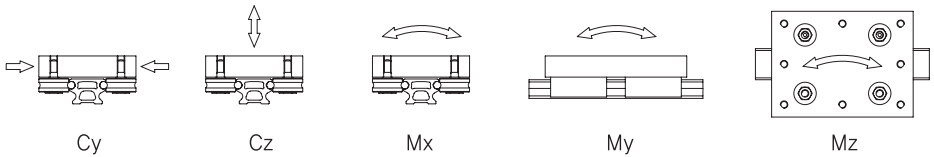

Part No.	Basic load ratings				Permissible Moment					
	Cy (N)	Coy (N)	Cz (N)	Coz (N)	Mx (N·m)	Mox (N·m)	My (N·m)	Moy (N·m)	Mz (N·m)	Moz (N·m)
TC 20	1860	1600	870	760	7.0	6.1	21.8	19.0	46.7	40.0
TC 25	5960	4560	2850	2200	27.1	20.9	78.4	60.5	164	125
TC 52	13930	10200	6620	4920	139	103	298	221	627	459

※ Please inquire us for your specially required dimensions & application

※ The figure of rating load and moment is for life time calculation and the figure of maximum allowable load could be referred to P260.

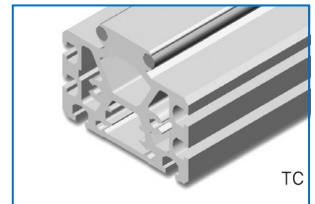
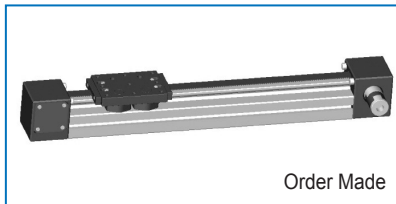

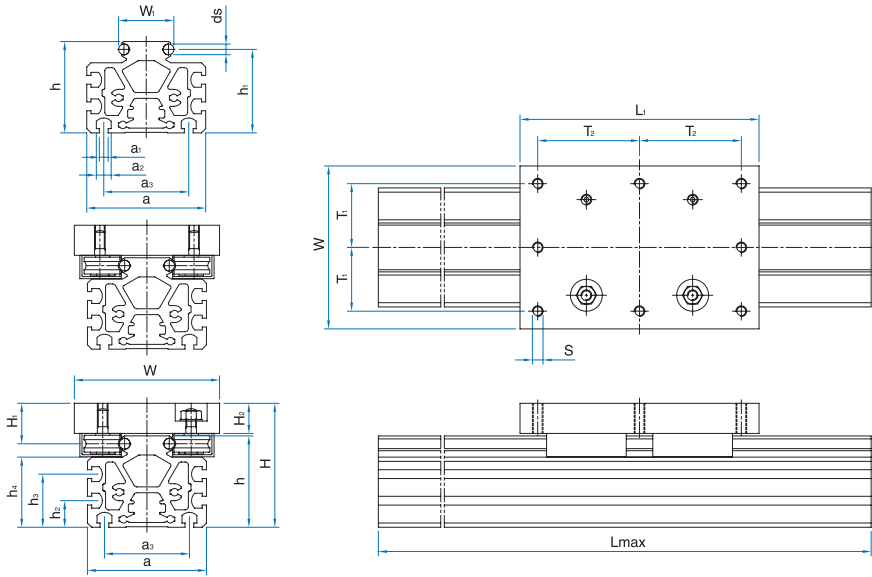

Unit : mm

Part No.	Basic load ratings			Block							Rail									
	W	W ₁	L (max.)	L ₁	H	H ₁	H ₂	S	T ₁	T ₂	a	a ₁	a ₂	a ₃	d _s	h	h ₁	h ₂	h ₃	h ₄
TC 20	60	20	6000	110	57	16,5	12,5	M 5	25	50	56	5,3	8,3	30	4	43,7	40,5	22	-	31,5
TC 25	85	25	6000	125	81,1	23,5	17	M 6	35	55	75	8,3	14	43	6	62	57,6	25	-	47
TC 52	130	52	3000	205	113,5	34,9	25,2	M10	52,5	90	112	8,3	14	80	10	86	78,6	25	50	66

※ Please refer to 286pages for the standards.

1N ≒ 0.102kgf
1N·m ≒ 0.102kgf·m

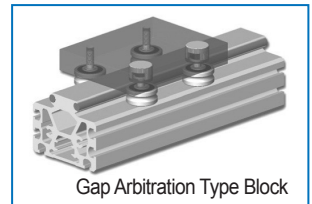
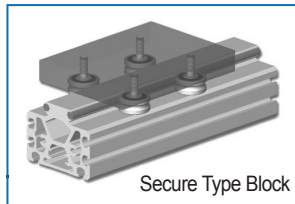

TF type

Examples of model number formation

TF	32	-	2	BC	S	-	1300
1	2		3	4	5		6

- 1** Type **2** Part No. **3** Block Quantity
4 Block Type : Secure Type Block(B), Gap Arbitration Block(BC)
5 Capseal : No Sticking(No symbol), Sticking(S) **6** Rail Length

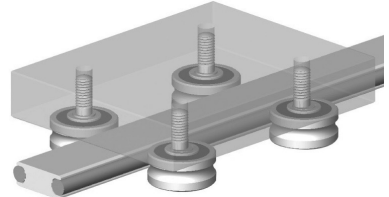

Basic Static Load Ratings and Moment

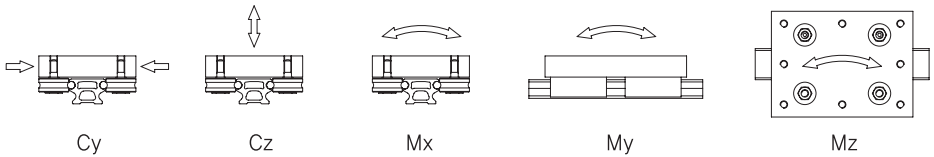

Part No.	Basic load ratings				Permissible Moment					
	Cy (N)	Coy (N)	Cz (N)	Coz (N)	Mx (N·m)	Mox (N·m)	My (N·m)	Moy (N·m)	Mz (N·m)	Moz (N·m)
TF 32	5960	4560	2850	2200	37.1	28.6	92.6	71.5	193	148
TF 42	13930	10200	6620	4920	106	78.7	231	172	487	357
TF 52	13930	10200	6620	4920	139	103	298	221	627	459

※ Please inquire us for your specially required dimensions & application

※ The figure of rating load and moment is for life time calculation and the figure of maximum allowable load could be referred to P260.

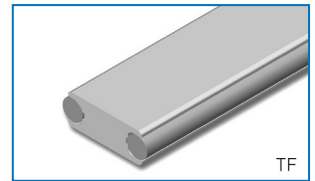

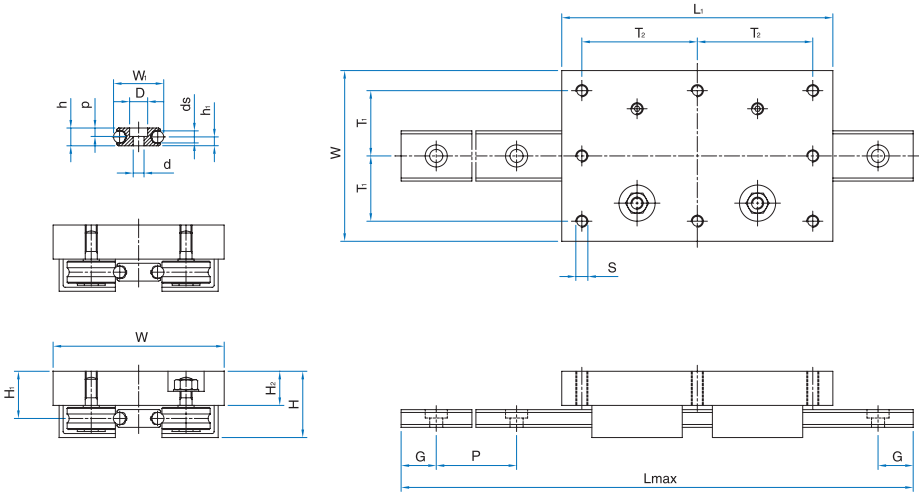

Unit : mm

Part No.	Basic load ratings			Block							Rail					
	W	W ₁	L (max.)	L ₁	H	H ₁	H ₂	S	T ₁	T ₂	ds	h	h ₁	d×D×p	G	P
TF 32	90	32	6000	145	33	23,5	17	M 6	37,5	65	6	10	5	6,5×12×6,5	25	125
TF 42	120	42	6000	170	47,2	34,9	25,2	M 8	50	75	10	15	7,5	9×15×7	25	125
TF 52	130	52	6000	205	47,2	34,9	25,2	M10	52,5	90	10	18	9	11×19×10	25	250

1N ≙ 0.102kgf
 1N·m ≙ 0.102kgf · m

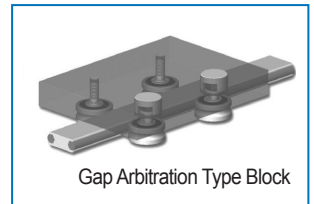
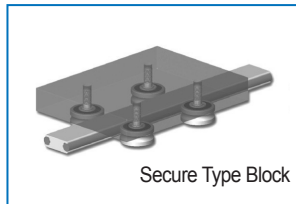

T.R Guide

TW type

Examples of model number formation

TW	52	-	2	BC	S	-	1425
1	2		3	4	5		6

- 1** Type **2** Part No. **3** Block Quantity
4 Block Type : Secure Type Block(B), Gap Arbitration Block(BC)
5 Capseal : No Sticking(No symbol), Sticking(S) **6** Rail Length

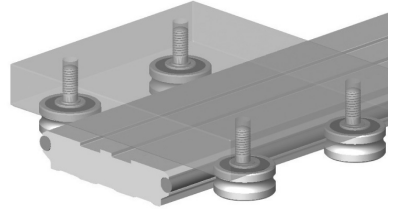

Basic Static Load Ratings and Moment

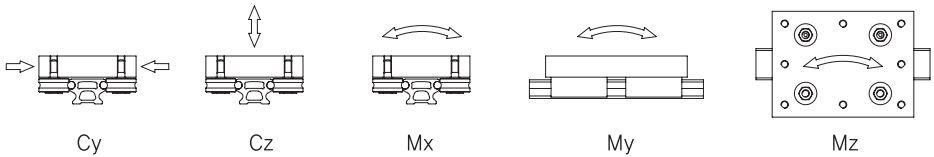

Part No.	Basic load ratings				Permissible Moment					
	Cy (N)	Coy (N)	Cz (N)	Coz (N)	Mx (N·m)	Mox (N·m)	My (N·m)	Moy (N·m)	Mz (N·m)	Moz (N·m)
TW 52	13938	10200	6620	4920	364.3	270.6	298.1	221.4	627.2	459.0

※ Please inquire us for your specially required dimensions & application

※ The figure of rating load and moment is for life time calculation and the figure of maximum allowable load could be referred to P260.

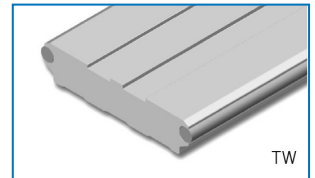

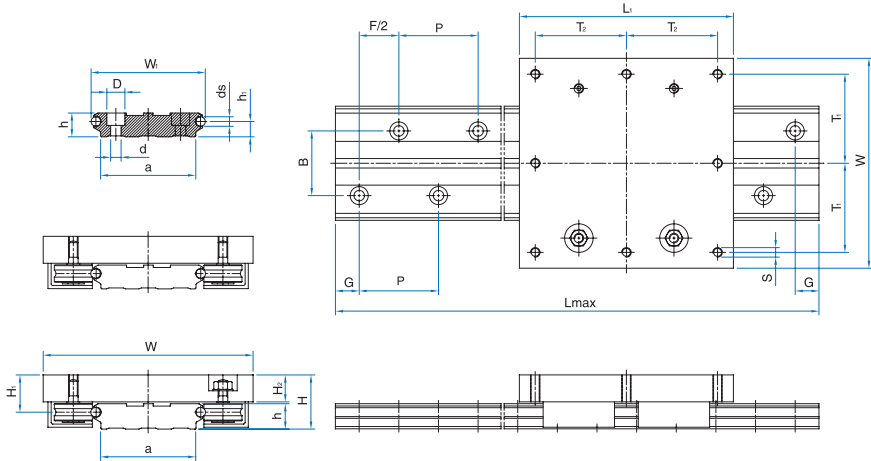

Unit : mm

Part No.	Basic load ratings				Block						Rail							
	W	W ₁	L (max.)	L ₁	H	H ₁	H ₂	S	T ₁	T ₂	a	ds	h	h ₁	B	d×D×P	G	P
TW 52	200	120	6000	205	51	34.9	25.2	M10	87.5	90	100	10	25	16.1	68	11×19×13	25	250

1N ≅ 0.102kgf
 1N·m ≅ 0.102kgf·m

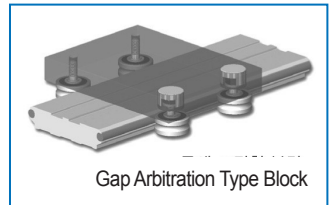
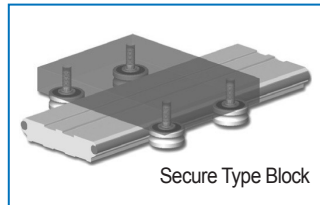

T.R Guide

TRI - Standard Type

Examples of model number formation

TRI 25 □ - 2 BC UU - 1300

1 2 3 4 5 6 7

- 1 Type 2 Part No.
- 3 Block Length : Standard(No Symbol), Long Type(L)
- 4 Block Quantity
- 5 Block Type : Secure Block(B), Adjustment Block(BC)
- 6 Seal : No Seal(No Symbol), One Side Seal(U), Both Side Seal(UU)
- 7 Rail Length



Basic Static Load Ratings and Moment

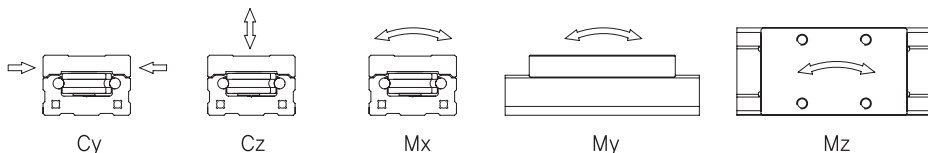

Part No.	Basic load ratings				Permissible Moment					
	Cy (N)	Coy (N)	Cz (N)	Coz (N)	Mx (N·m)	Mox (N·m)	My (N·m)	Moy (N·m)	Mz (N·m)	Moz (N·m)
TRI 15	1860	1600	710	570	8,3	5,4	12,1	9,7	31,8	27,2
TRI 20	1860	1600	710	570	8,5	6,8	12,8	10,3	33,6	28,8
TRI 25	5960	4560	2330	1650	36,1	25,6	58,3	41,3	149	114
TRI 30	5960	4560	2330	1650	41,9	29,7	62,9	44,6	161	123
TRI 35	13900	10200	5410	3690	121	83,0	195	132	501	367
TRI 45	13900	10200	5410	3690	135	92,3	200	136	515	377
TRI 55	13900	10200	5410	3690	162	110	243	166	627	459

- ※ Please inquire us for your specially required dimensions & application
- ※ The figure of rating load and moment is for life time calculation and the figure of maximum allowable load could be referred to P261.

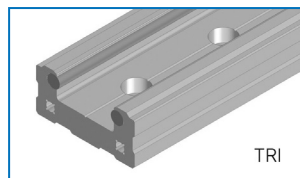

TRI

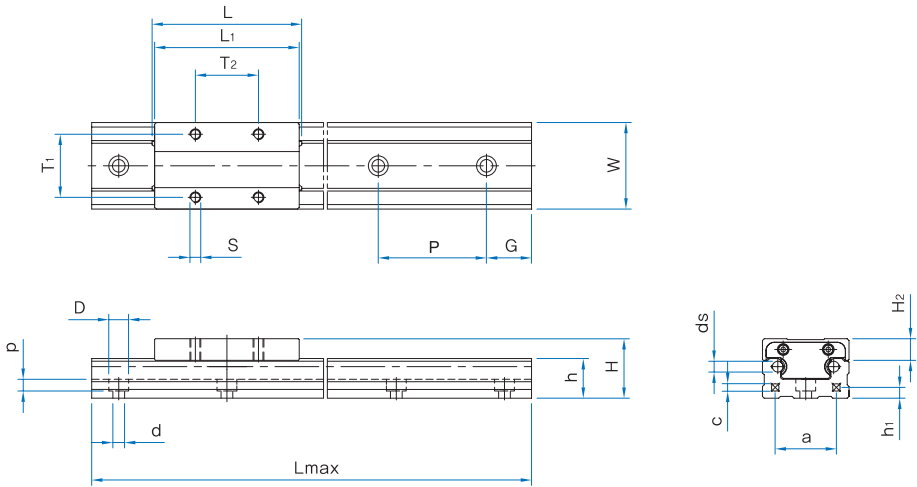

Unit : mm

Part No.	Basic load ratings				Block					Rail							
	W	H	L	L _(max.)	L ₁	H ₂	S	T ₁	T ₂	ds	h	h ₁	a	c	d×D×p	G	P
TRI 15	34	24	57	6000	54,2	10,3	M4	26	26	4	14,7	4	24	3,3	4,5×8×4,5	25	60
TRI 20	42	28	66.2	6000	63,4	11,3	M5	32	32	4	17,7	5	30	3,3	5,5×9,4×5,5	25	60
TRI 25	48	33	83	6000	80,2	12	M6	35	35	6	22	6	34	4,2	6,5×11×6,5	25	60
TRI 30	60	42	96.8	6000	94	17,5	M8	40	40	6	26	7	44	5	6,5×11×6,5	35	80
TRI 35	70	48	117	6000	114,2	18,5	M8	50	50	10	31,5	8	50	6,8	9×14×9	35	80
TRI 45	86	60	126	6000	123,2	23	M10	60	60	10	39,5	12	60	6,8	11×17,5×11	50	105
TRI 55	100	68	156	6000	153,2	28	M12	75	75	12	43,5	12	70	8,5	13×20×13	50	120

1N ≅ 0.102kgf

1N·m ≅ 0.102kgf·m

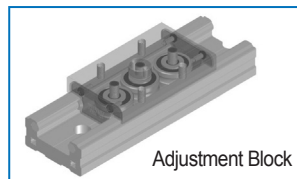
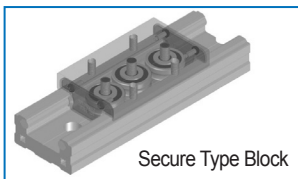

TRI - Long Type

Examples of model number formation

TRI 25 L - 2 BC UU - 1300

1 2 3 4 5 6 7

- 1 Type 2 Part No.
- 3 Block Length : Standard(No Symbol), Long Type(L)
- 4 Block Quantity
- 5 Block Type : Secure Block(B), Adjustment Block(BC)
- 6 Seal : No Seal(No Symbol), One Side Seal(U), Both Side Seal(UU)
- 7 Rail Length



Basic Static Load Ratings and Moment

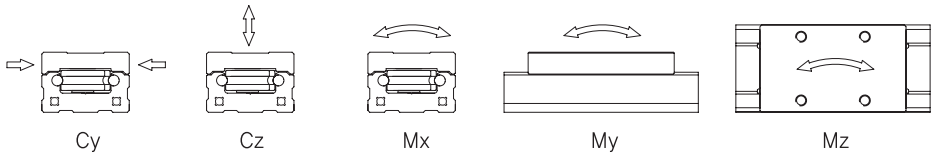

Part No.	Basic load ratings				Permissible Moment					
	Cy (N)	Coy (N)	Cz (N)	Coz (N)	Mx (N-m)	Mox (N-m)	My (N-m)	Moy (N-m)	Mz (N-m)	Moz (N-m)
TRI 15L	1860	1600	870	760	8.3	7.2	23.2	20.3	49.9	42.7
TRI 20L	1860	1600	870	760	10.5	9.1	28.7	25.1	61.6	52.8
TRI 25L	5960	4560	2850	2200	44.2	34.1	106	82.5	223	171
TRI 30L	5960	4560	2850	2200	51.3	39.6	124	95.7	259	198
TRI 35L	13900	10200	6620	4920	149	110	357	265	752	550
TRI 45L	13900	10200	6620	4920	165	123	397	295	836	612
TRI 55L	13900	10200	6620	4920	198	147	486	361	1024	749

- ※ Please inquire us for your specially required dimensions & application
- ※ The figure of rating load and moment is for life time calculation and the figure of maximum allowable load could be referred to P261.

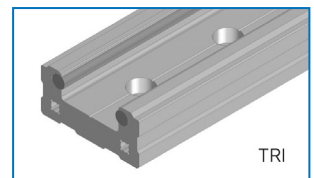

TRI

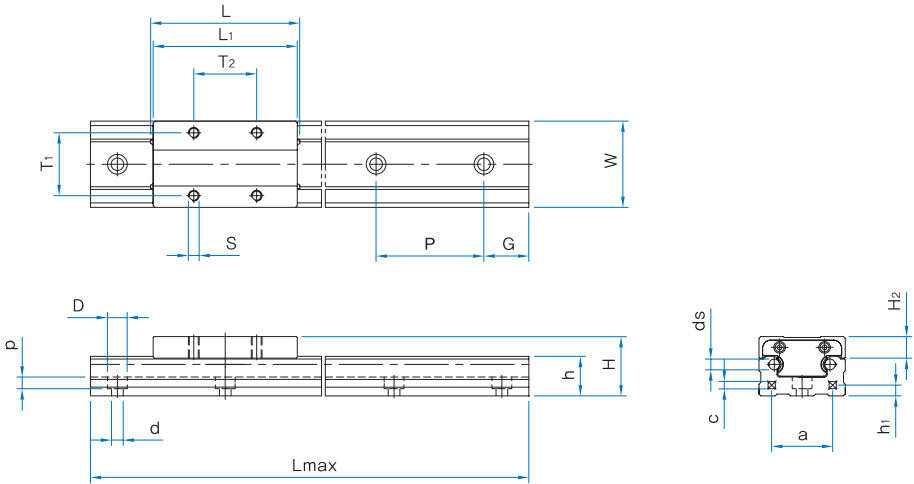

Unit : mm

Part No.	Basic load ratings				Block						Rail						
	W	H	L	L (max.)	L ₁	H ₂	S	T ₁	T ₂	ds	h	h ₁	a	c	d×D×p	G	P
TRI 15L	34	24	79.4	6000	76.6	10.3	M4	26	34	4	14.7	4	24	3.3	4.5×8×4.5	25	60
TRI 20L	42	28	98	6000	95.2	11.3	M5	32	50	4	17.7	5	30	3.3	5.5×9.4×5.5	25	60
TRI 25L	48	33	109	6000	106.2	12	M6	35	50	6	22	6	34	4.2	6.5×11×6.5	25	60
TRI 30L	60	42	131	6000	128.2	17.5	M8	40	60	6	26	7	44	5	6.5×11×6.5	35	80
TRI 35L	70	48	152	6000	149.2	18.5	M8	50	72	10	31.5	8	50	6.8	9×14×9	35	80
TRI 45L	86	60	174	6000	171.2	23	M10	60	80	10	39.5	12	60	6.8	11×17.5×11	50	105
TRI 55L	100	68	213	6000	210.2	28	M12	75	95	12	43.5	12	70	8.5	13×20×13	50	120

T.R Guide

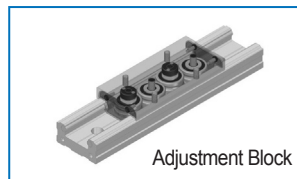
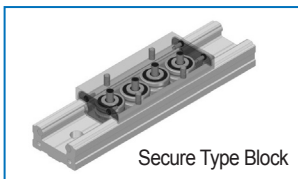

1N ≅ 0.102kgf
1N·m ≅ 0.102kgf·m

RF type / RA type

Track Roller(Outside Type)

Examples of model number formation

- 1 Type : Coaxial Shaft Roller(RF), Eccentric Shaft Roller(RA)
- 2 Part No.

RF

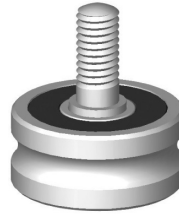

RA



The load of an application roller

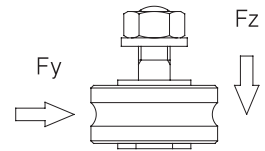
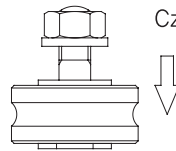
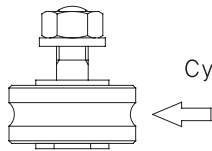

Part No.	C_y (N)	C_{oy} (N)	C_z (N)	C_{oz} (N)	$F_{y\max.}$ (N)	$F_{z\max.}$ (N)
RF 04	1150	800	330	190	250	100
RA 04						
RF 06	3670	2280	1080	550	920	270
RA 06						
RF 10	8580	5100	2510	1230	2200	630
RA 10						
RF 12	8580	5100	2510	1230	2200	630

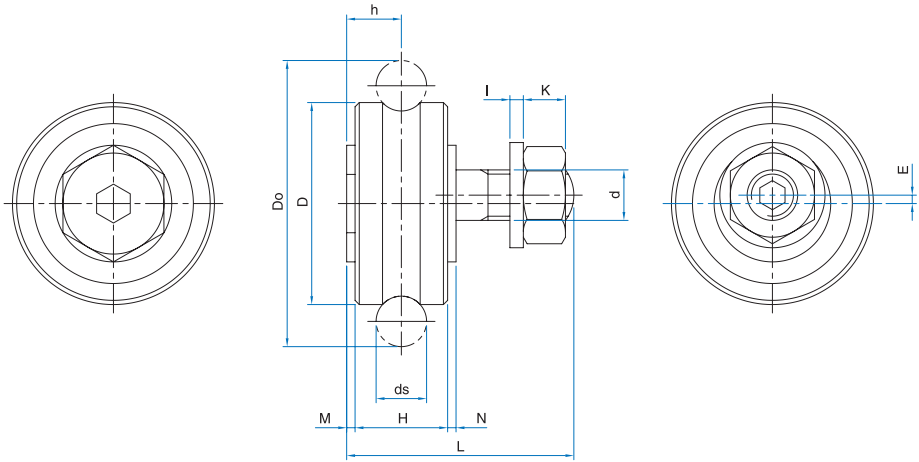

Unit : mm

Part No.	ds	d	D	D ₀	H	h	E	M	N	L	I	K	Application Rail
RF 04	4	4	16	22	7	5	-	1.5	0.5	18.5	0.5	2.4	20
RA 04							0.5						
RF 06	6	6	24	34	11	6.5	-	1	1	27	1.6	5	25, 32
RA 06							1						
RF 10	10	10	35	51.3	15.9	8.95	-	1	1.7	40.5	2	8	42, 52
RA 10							1						
RF 12	12	10	42	60.93	19	9.5	-	-	3	43.2	1	12.5	55

T.R Guide

RFI type Track Roller(Inside Type)

Examples of model number formation

RFI	04
1	2

1 Type : Coaxial Shaft Roller(RFI)
2 Part No.

RFI

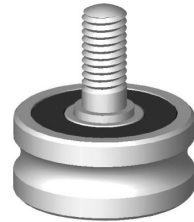

The load of an application roller and moment

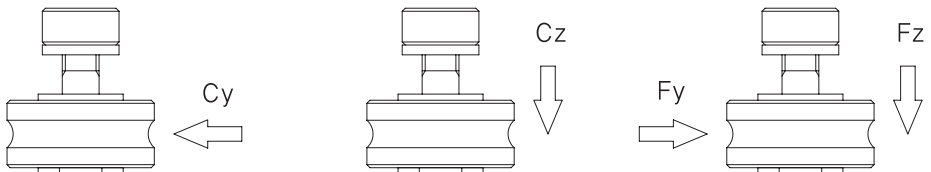

Part No.	C_y (N)	C_{oy} (N)	C_z (N)	C_{oz} (N)	$F_{y\max.}$ (N)	$F_{z\max.}$ (N)
RFI 04	1150	800	330	190	250	100
RFI 06	3670	2280	1080	550	920	270
RFI 10	8580	5100	2510	1230	2200	630
RFI 12	8580	5100	2510	1230	2200	630

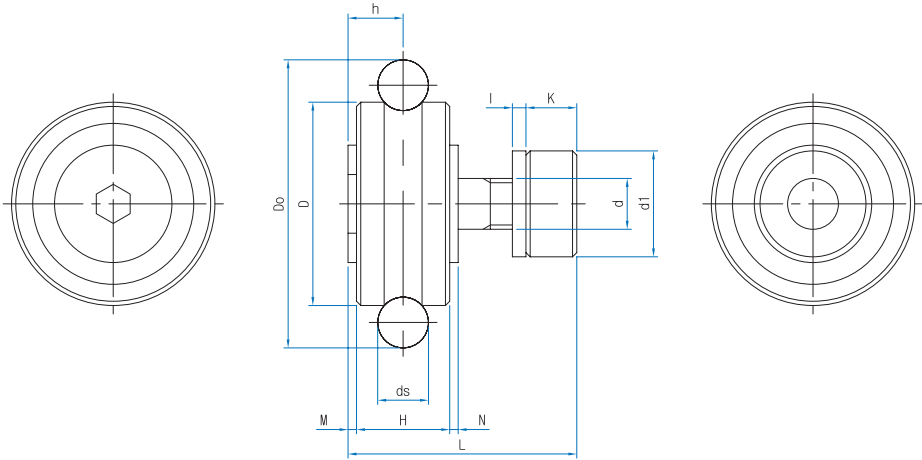

Unit : mm

Part No.	ds	d	D	Do	H	h	d1	M	N	L	I	K	Application Rail
RFI 04	4	4	16	22	7	5	10	1.5	0.5	17	0.5	5.5	TRI 15
RFI 04-1										18			TRI 20
RFI 06	6	6	24	34	11	6.5	14	1	1	21.5	0.5	6	TRI 25
RFI 06-1										25.9			TRI 30
RFI 10	10	10	35	51.3	15.9	8.95	22	1	1.75	33.35	1	9	TRI 35
RFI 10-1										37.35			TRI 45
RFI 12	12	12	42	60.93	19	9.5	22	-	3	43.2	1	12.5	TRI 55

T.R Guide

S type Cap Seal

Examples of model number formation

S	04
1	2

1 Type
2 Part No.

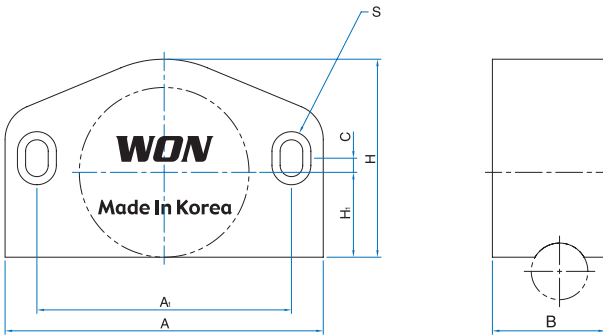
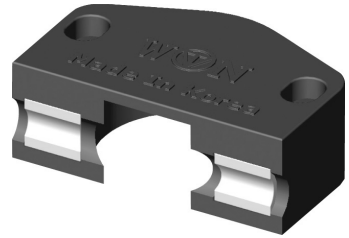

Unit : mm

Part No.	A	A ₁	B	H	H ₁	C	S	Application Roller
S 04	38	30	12	20	8	10	3,2×6×3,5	RF, RA 04
S 06	45	36	16	28	12	14		RF, RA 06
S 10	60	50	22	39	17.5	19.5		RF , RA 10

T type End Seal

Examples of model number formation

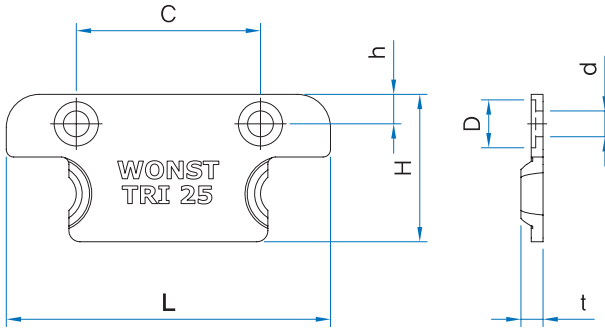
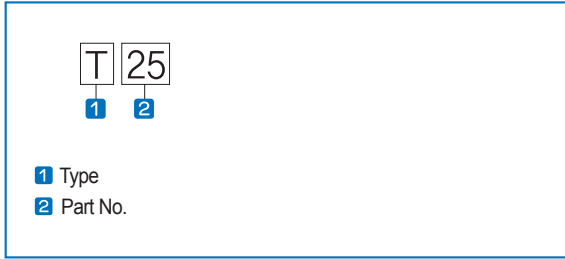

Unit : mm

Part No.	L	H	t	C	h	D	d
T 15	30	15.5	3	20	3	5.5	3.5
T 20	38	16.5	3	22	4	5.5	3.5
T 25	44	20	3	25	4	6	3.5
T 30	56	24.4	3	36	6	8	4.5
T 35	65	31.9	3	40	7	8	4.5
T 45	80	35.4	3	46	9	8	4.5
T 55	94	40.7	3	66	9.5	8	4.5

B type Bracket

Examples of model number formation

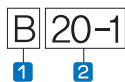

- 1 Type
- 2 Part No.

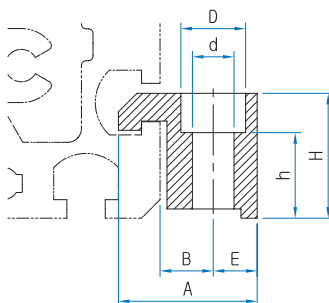
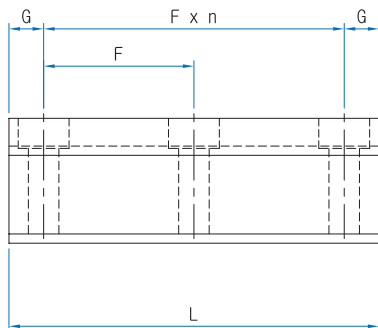
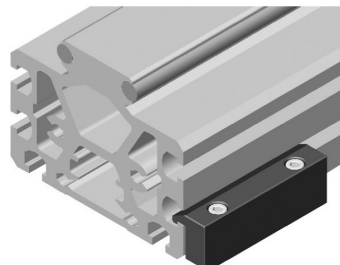

Unit : mm

Part No.	A	B	H	L	d×D	h	E	F×n	G
B 20-1	20	7	23,5	40	6,6×11	17	7,5	25 ×1	7,5
B 20-2				65				25 ×2	
B 25-1	28	10	27	47,5	6,6×11	20,5	9	32,5×1	7,5
B 25-2				80				32,5×2	
B 52-1	30	11,5	27	70	9 ×14	18,5	9,5	55 ×1	7,5
B 52-2				125				55 ×2	

Bracket Assembly Torque

Part No.	M5	M6	M8
Max (N·m)	5,8	9,9	24

 $1\text{N}\cdot\text{m} \approx 0.102\text{kgf}\cdot\text{m}$

Micro Stage

Contents

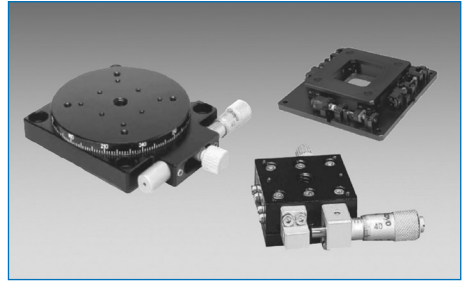

1	Linear Stage (Manual Stage)	288
2	Dovetail Stage (Manual Stage)	292
3	Dovetail Stage / Z Stage (Manual Stage)	293
4	Rotary Stage (Manual Stage)	294
5	Tilting Stage (Manual Stage)	296
6	Z Stage (Manual Stage)	297
7	Miniature Stage (Motorized Stage)	298
8	Miniature Stage / Z Stage (Motorized Stage)	299
9	Rotary Stage / Linear Stage (Motorized Stage)	300
10	Alignment Stage (Motorized Stage)	301

Linear Stage (Manual Stage)



M1-338-L1

M1-338-R1

M1-338-L1,R1,C1	
Stage Surface : 30X30mm	
Stroke	±3mm
Travel Guide	Crossed Roller Guide
Resolution	0.01mm
Load Capacity	1.5kg
Material	Aluminum

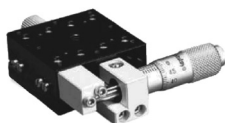
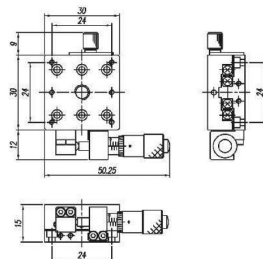

M1-437-L1

M1-437-L1,R1,C1	
Stage Surface : 40X40mm	
Stroke	±6.5mm
Travel Guide	Crossed Roller Guide
Resolution	0.01mm
Load Capacity	2kg
Material	Slim Aluminum

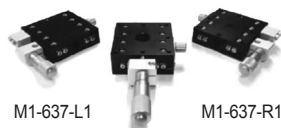
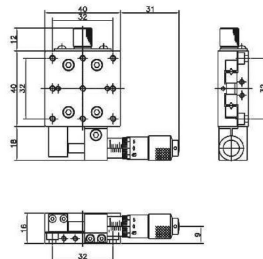

M1-637-L1

M1-637-R1

M1-637-C1

M1-637-L1,R1,C1	
Stage Surface : 60X60mm	
Stroke	±6.5mm
Travel Guide	Crossed Roller Guide
Resolution	0.01mm
Load Capacity	5kg
Material	Slim Aluminum

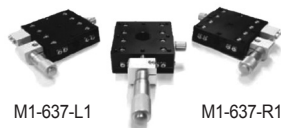
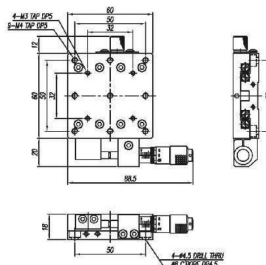

M1-837-L1

M1-837-R1

M1-837-C1

M1-837-L1,R1,C1	
Stage Surface : 80X80mm	
Stroke	±12mm
Travel Guide	Crossed Roller Guide
Resolution	0.01mm
Load Capacity	10kg
Material	Slim Aluminum

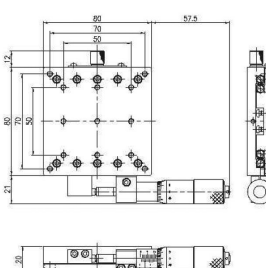



M1-1037-L1

M1-1037-L1,R1,C1

Stage Surface : 100X100mm

Stroke	±12.5mm
Travel Guide	Crossed Roller Guide
Resolution	0.01mm
Load Capacity	10kg
Material	Slim Aluminum

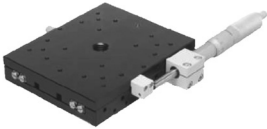
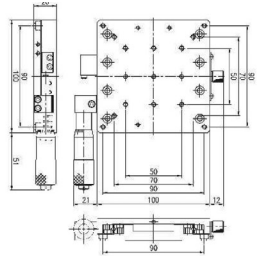

M1-238-R1

M1-238-L1,R1,C1

Stage Surface : 125X150mm

Stroke	±25mm
Travel Guide	Crossed Roller Guide
Resolution	0.01mm
Load Capacity	8kg
Material	Aluminum

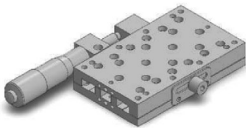
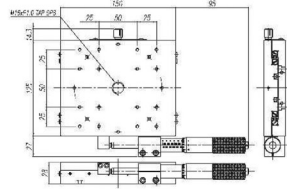

M1-6137-L1

M1-6137-L1,R1,C1

Stage Surface : 60X100mm

Stroke	±12.5mm
Travel Guide	Crossed Roller Guide
Resolution	0.01mm
Load Capacity	6kg
Material	Slim Aluminum

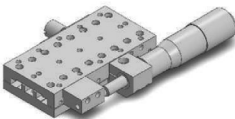
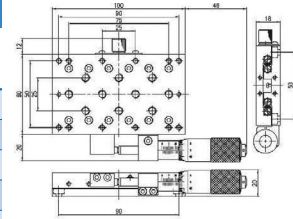

M1-4837-R1

M1-4837-L1,R1,C1

Stage Surface : 40X80mm

Stroke	±12mm
Travel Guide	Crossed Roller Guide
Resolution	0.01mm
Load Capacity	6kg
Material	Slim Aluminum

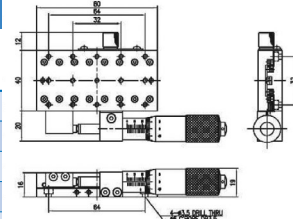

Micro Stage

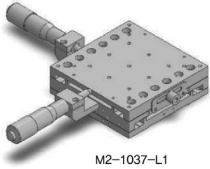

M2-1037-L1

M2-1037-L1,R1,C1

Stage Surface : 40X80mm

Stroke	±12.5mm
Travel Guide	Crossed Roller Guide
Resolution	0.01mm
Load Capacity	10kg
Material	Slim Aluminum

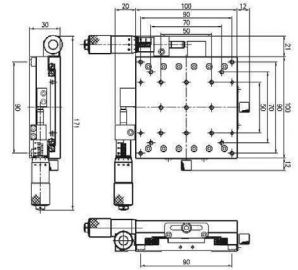

M3-437-L1

M3-437-L1,R1,C1

Stage Surface : 40X40mm

Stroke	±6.5mm
Travel Guide	Crossed Roller Guide
Resolution	0.01mm
Load Capacity	1kg
Material	Slim Aluminum

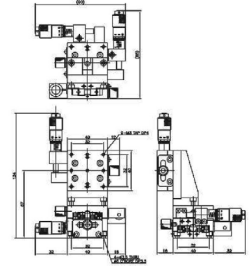

M3-637-L1

M3-637-L1,R1,C1

Stage Surface : 60X60mm

Stroke	±6.5mm
Travel Guide	Crossed Roller Guide
Resolution	0.01mm
Load Capacity	2kg
Material	Slim Aluminum

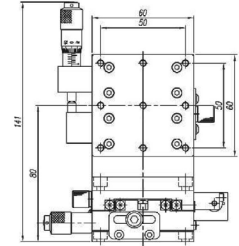

» Dovetail Stage (Manual Stage)



D1-2518-L1

D1-2518-L6

Stage Surface : 25X25mm

Stroke	±5mm
Travel Guide	Dovetail Type, Screw
Load Capacity	1kg
Material	Aluminum

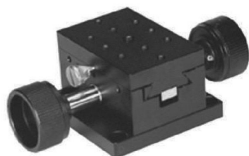
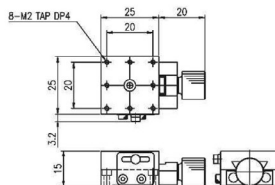

D1-418-L5W

D1-418-L5W

Stage Surface : 40X40mm

Stroke	±10mm
Travel Guide	Dovetail Rack & Pinion
Load Capacity	2.5kg
Material	Aluminum

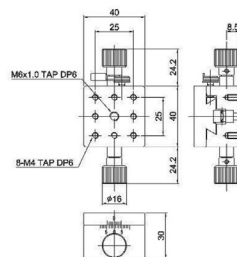

D1-418-L6

D1-418-L6,R6

Stage Surface : 40X40mm

Stroke	±5mm
Travel Guide	Dovetail Type, Screw
Load Capacity	2.5kg
Material	Aluminum

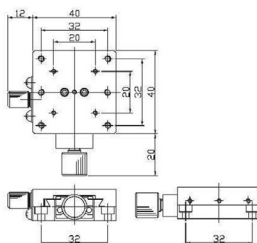

D1-618-L5

D1-618-L5

Stage Surface : 40X60mm

Stroke	±15mm
Travel Guide	Dovetail Rack & Pinion
Load Capacity	3kg
Material	Aluminum

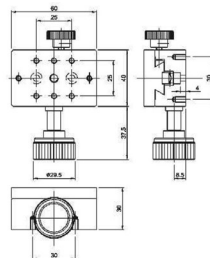

» Dovetail Stage / Z Stage (Manual Stage)



D1-118-L5

D1-118-L5	
Stage Surface : 40X140mm	
Stroke	±50mm
Travel Guide	Dovetail Rack & Pinion
Load Capacity	4kg
Material	Aluminum

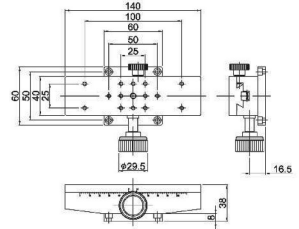

D1-618-L6

D1-618-L6,R6	
Stage Surface : 60X60mm	
Stroke	±10mm
Travel Guide	Dovetail Type, Screw
Load Capacity	5kg
Material	Slim Aluminum

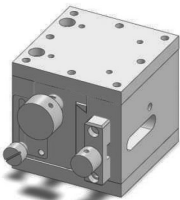
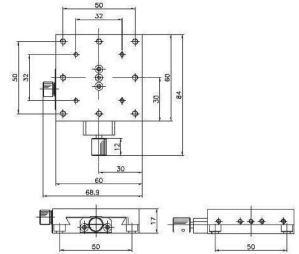

MXZ-637-C1

MXZ-637-C1	
Stage Surface : 60X60mm	
Stroke	X : ±5mm / Z : ±26mm
Travel Guide	Dovetail Type, Screw
Load Capacity	1kg
Material	Aluminum

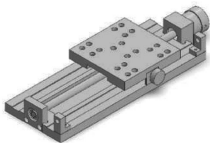
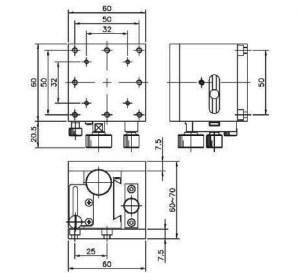

LD1-0810-4S

LD1-0810-4S	
Stroke	±50mm
Size	80x239x30mm
Load Capacity	LM
Resolution	0.1mm
Load Capacity	15kg

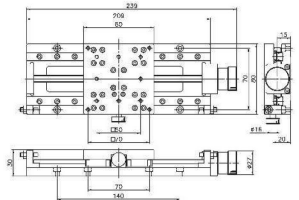

Micro Stage



R1-117-L1

R1-117-L1

Table Dimension	Ø125
Travel Range	360° / ±5°
Resolution	1°
Load Capacity	3kg
Material	Aluminum

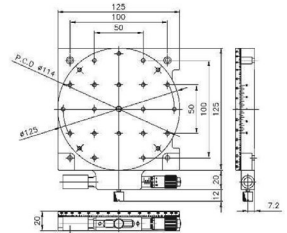

R1-117-L4

R1-117-L4

Table Dimension	Ø125
Travel Range	360°
Resolution	1°
Load Capacity	3kg
Material	Aluminum

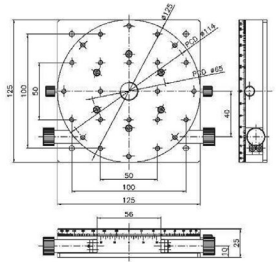

▶▶ Tilting Stage (Manual Stage)



T1-418-A4

T1-418-A4

Stroke	±20°
Table Dimension	40x40mm
Travel Guide	Dovetail, Worm Gear
Load Capacity	1.5kg
Material	Aluminum

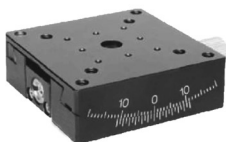
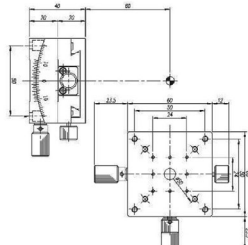

T1-618-D4

T1-618-D4

Stroke	±10°
Table Dimension	60x60mm
Travel Guide	Dovetail, Worm Gear
Load Capacity	3kg
Material	Aluminum

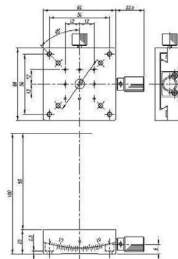

T1-818-D4

T1-818-D4

Stroke	±10°
Table Dimension	80x80mm
Travel Guide	Dovetail, Worm Gear
Load Capacity	4kg
Material	Aluminum

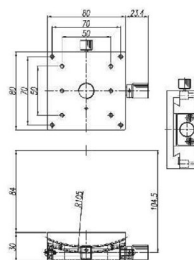

T1-818-E4

T1-818-E4

Stroke	±10°
Table Dimension	80x80mm
Travel Guide	Dovetail, Worm Gear
Load Capacity	4kg
Material	Aluminum

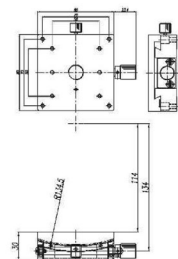

» Z Stage (Manual Stage)



T1-418-A4

MZ-437D-C1	
Stage Surface : 40X40mm	
Stroke	±3mm
Travel Guide	Crossed Roller Guide
Resolution	0.01mm
Load Capacity	1.5kg
Material	Slim Aluminum

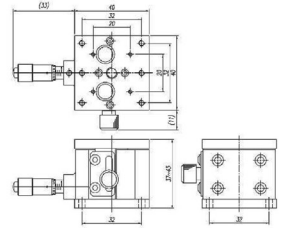

T1-418-A4

MZ-637D-C1	
Stage Surface : 60X60mm	
Stroke	±5mm
Travel Guide	Crossed Roller Guide
Resolution	0.01mm
Load Capacity	5kg
Material	Slim Aluminum

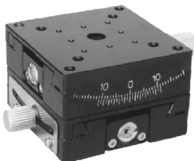
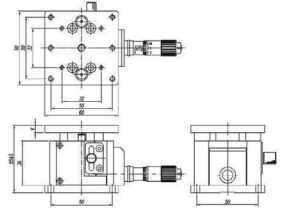

T1-418-A4

MZ-137D-C1	
Stage Surface : 125X125mm	
Stroke	±5mm
Travel Guide	Crossed Roller Guide
Resolution	0.01mm
Load Capacity	5kg
Material	Slim Aluminum

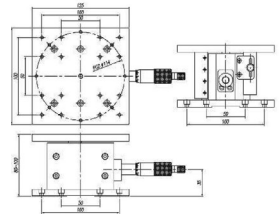

▶▶ Miniature Stage / Z Stage (Motorized Stage)

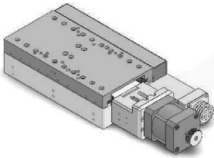

AM1-0810-3S

AM1-0810-3S

Stage Surface : 80X160mm

Stroke	10mm
Travel Guide	B/S Ø8L1.Cross Roller
Resolution	0.002mm/Pulse(Full Step)
Load Capacity	15kg
Material	Aluminum(Option. SUS)

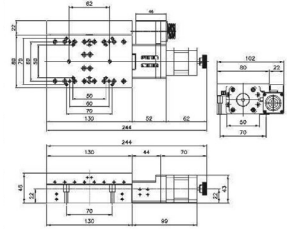

AZ-0808-3S

AZ-0808-3S

Stage Surface : 80X100mm

Stroke	8mm
Travel Guide	B/S Ø6L1.Cross Roller
Resolution	0.0072mm/Pulse(Full Step)
Load Capacity	10kg
Material	Aluminum(Option. SUS)

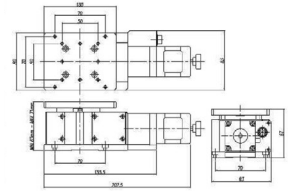

AZ-1212-3S

AZ-1212-3S

Stage Surface : 120X120mm

Stroke	12mm
Travel Guide	B/S Ø8L1.Cross Roller
Resolution	0.0072mm/Pulse(Full Step)
Load Capacity	20kg
Material	Aluminum(Option. SUS)

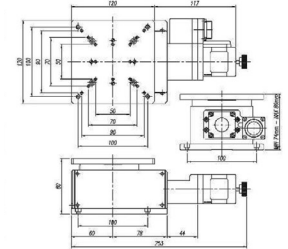

Rotary Stage / Linear Stage (Motorized Stage)



AR-0600-2S

AR-0600-2S

Stage Surface : $\varnothing 60$

Stroke	360°
Travel Guide	Worm Gear, 1/180
Resolution	0.004°/Pulse(Full Step)
Load Capacity	3kg
Material	Aluminum

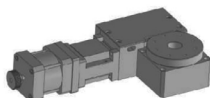
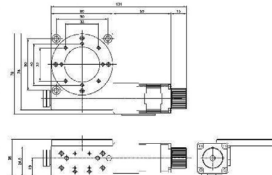

AR-0611-4S

AR-0611-4S

Stage Surface : $\varnothing 60$

Stroke	$\pm 5^\circ$
Travel Guide	B/S $\varnothing 6L1$, LM GUIDE
Resolution	0.002mm/Pulse(Full Step)
Load Capacity	5kg
Material	Aluminum

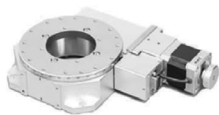
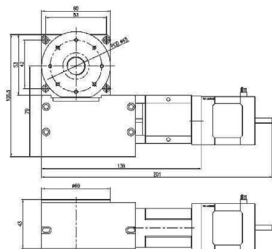

AR-1200-3S

AR-1200-3S

Stage Surface : $\varnothing 125$

Stroke	360°
Travel Guide	Worm Gear, 1/180
Resolution	0.004°/Pulse(Full Step)
Load Capacity	15kg
Material	Steel + Aluminum

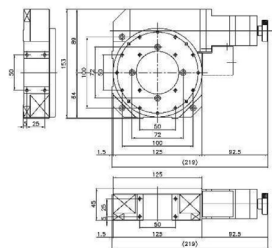

AL1-1520-3S

AL1-1520-3S

Stage Surface : 150X320mm

Stroke	200mm
Travel Guide	B/S $\varnothing 12L5$.Cross Roller
Resolution	0.01mm/Pulse(Full Step)
Load Capacity	25kg
Material	Aluminum(Option. SUS)

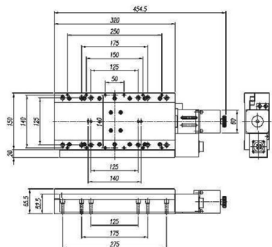

Alignment Stage (Motorized Stage)



AA-200-3S

AA-200-3S

Stage Surface : 200X200mm

Stroke	$\pm 5 / \pm 5 / \pm 2.5^\circ$ (mm)
Travel Guide	B/S Ø8 L1, Cross Roller
Resolution	0.002/Pulse(Full Step)
Load Capacity	30kg
Material	Aluminum(Option. SUS)

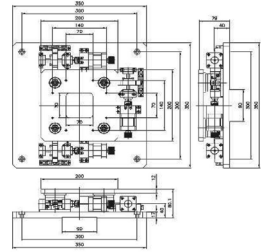

AA-400-3S

AA-400-3S

Stage Surface : 400X400mm

Stroke	$\pm 10 / \pm 10 / \pm 2.5^\circ$ (mm)
Travel Guide	B/S Ø14 L2, Cross Roller
Resolution	0.004/Pulse(Full Step)
Load Capacity	80kg
Material	Aluminum(Option. SUS)

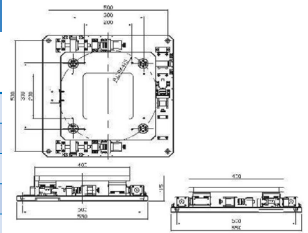



AA-1000-3S

AA-1000-3S

Stage Surface : 1000X1000mm

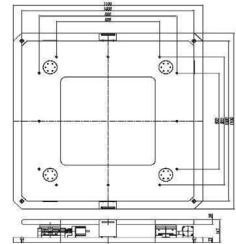
Stroke	$\pm 15 / \pm 15 / \pm 2.5^\circ$ (mm)
Travel Guide	B/S Ø14 L2, Cross Roller
Resolution	0.004/Pulse(Full Step)
Load Capacity	100kg
Material	Aluminum(Option. SUS)





WON
LINEAR MOTION SYSTEM

Contents

■ Appendix

1. Conversion Table from SI (International System of Units)	304
2. N-kaf Conversion Table	306
3. kg-lb Conversion Table	307
4. Hardness Conversion Table	308
5. Dimensional Tolerance of Axis	310
6. Dimensional Tolerance of Housing Hole	312
7. Usage examples of Linear Motion Guide	314
8. Usage examples of Crossed Roller Bearing	322

1. Conversion from SI(International System of Units)

Comparison of SI, CGS, and Engineering Units

Unit System	Length	Mass	Time	Temp.	Acceleration	Force	Stress	Pressure	Energy	power
SI	m	kg	s	K, °C	m/s ²	N	Pa	Pa	J	W
CGS System	cm	g	s	°C	Gal	dyn	dyn/cm ²	dyn/cm ²	erg	erg/s
Engineering Unit System	m	kgf·s ² /m	s	°C	m/s ²	kgf	kgf/m ²	kgf/m ²	kgf·m	kgf·m/s

Conversion Factors from SI Units

Parameter	SI Units		Units other than SI		Conversion factors from SI units
	Names of unit	Symbols	Names and symbols of Unit		
Angle	Radian	rad	Degree	°	180/π
			Minute	'	10 180/π
			Second	"	648 000/π
Length	Meter	m	Micron	μ	10 ⁶
			Angstrom	Å	10 ¹⁰
Area	Square meter	m ²	Are	a	10 ⁻²
			Hectare	ha	10 ⁻⁴
Volume	Cubic meter	m ³	Liter	l, L	10 ³
			Deciliter	dl, dL	10 ⁴
Time	Second	s	Minute	min	1/60
			Hour	h	1/3 600
			Day	d	1/86 400
No. of vibration, frequency	Hertz	Hz	Cycle	s ⁻¹	1
Speed of rotation	Time per second	s ⁻¹	Time per minute	rpm	60
Speed	Meter per second	m/s	Kilometer per hour	km/h	3 600/1000
			Knot	kn	3 600/1852
Acceleration	Meter per second	m/s ²	Gal	Gal	10 ²
			g	G	1/9,806 65
Mass	Kilogram	kg	Ton	t	10 ⁻³
Force	Newton	N	Kilogram-force	kgf	1/9,806 65
			Ton-force	tf	1/(9,806 65 X 10 ³)
			Dyne	dyn	10 ⁵
Torque & force moment	Newton meter	N·m	Kilogram-force	kgf·m	1/9,806 65
Stress	Pascal (Newton per square meter)	Pa (N/m ²)	Kilogram-force per square centimeter	kgf/cm ²	1/(9,806 65 X 10 ⁻⁴)
				kgf/mm ²	1/(9,806 65 X 10 ⁶)

Prefix Used in SI Units

Multiples			Names and symbols of prefix			Multiples			Names and symbols of prefix		
10 ¹⁸	Exa	E	10 ⁻¹	Deci	d						
10 ¹⁵	Peta	P	10 ⁻²	Centi	c						
10 ¹²	Tera	T	10 ⁻³	Milli	m						
10 ⁹	Giga	G	10 ⁻⁶	Micro	μ						
10 ⁶	Mega	M	10 ⁻⁹	Nano	n						
10 ³	Kilo	k	10 ⁻¹²	Pico	p						
10 ²	Hecto	h	10 ⁻¹⁵	Femto	f						
10 ¹	Deca	da	10 ⁻¹⁸	Ato	a						

Conversion Factors from SI Units

Parameter	SI Units		Units other than SI		Conversion factors from SI units
	Names of unit	Symbols	Names and symbols of Unit		
Pressure	Pascal (Newton per square meter)	Pa (N/m ²)	Kilogram-force per square centimeter Aqua meter Mercury millimeter Torr Bar Atmosphere	kgf/m ² mmHg Torr bar atm	1/9,806 65 1/(9,806 65 X 10 ³) 760/(1,013 25 X 10 ⁵) 760/(1,013 25 X 10 ⁵) 10 ⁻⁵ 1/(1,013 25 X 10 ⁵)
Energy	Joule (Newton meter)	J (N · m)	Erg Calorie (international) Kilogram-force meter Kilowatt-hour French horsepower hour	erg cal _I kgf · m kW · h PS · h	10 ⁷ 1/4,186 8 1/9,806 65 1/(3.6 X 10 ⁶) ≈3,776 72 X 10 ⁻⁷
Power	Watt (Newton meter)	W (J/s)	Kilogram-force per second Kilogram per hour French horsepower hour	kgf · m/s kcal/h PS	1/9,806 65 1/1,163 ≈1/735,498 8
Viscosity, viscosity index	Pascal	Pa · s	Poise	P	10
Kinematic viscosity, Kinematic viscosity index	Square meter/second	m ² /s	Stokes Centistokes	St cSt	10 ⁴ 10 ⁶
Temperature, Temperature variation	Kelvin, Celsius	K, °C	Degree	°C	[See Note 1]
Current, magnetomotive force	Ampere	A	Ampere	A	1
Current, electromotive force	Volt	V	(Watt/ampere)	(W/A)	1
Magnetic intensity	Ampere per meter	A/m	Oersted	Oe	4π/10 ³
Magnetic flux density	Tesla	T	Gauss Gamma	Gs γ	10 ⁴ 10 ⁹
Electric resistance	Ohm	Ω	Ampere/volt	(V/A)	1

Note 1 The temperature conversion from from TK to θ°C is θ°=T-273.15, but for a temperature variation, it is ΔT=Δθ. But ΔT and Δθ represent temperature variation measured using the Kelvin and Celsius scales respectively.

Remarks The names and symbols in parenthesis are equivalent to those directly above or on the left

Example 1N=1/9,809 65kg

2. N-kgf Conversion Table

[How to Read] For example, to convert 10N into kgf, read the figure in the right kgf column adjacent to the 10 in the center column in the 1st block. This means that 10N is 1.0197kgf. To convert 10kgf into N, read the figure in the left N column of the same row, which indicates that the answer is 98,066N.

$$1\text{N}=0.1019716\text{kgf}$$

$$1\text{kgf}=9.80665\text{N}$$

N		kgf	N		kgf	N		kgf
9,8066	1	0.1020	333,43	34	3,4670	657,05	67	6,8321
19,613	2	0,2039	343,23	35	3,5690	666,85	68	6,9341
29,420	3	0,3059	353,04	36	3,6710	676,66	69	7,0360
39,227	4	0,4079	362,85	37	3,7729	686,47	70	7,1380
49,033	5	0,5099	372,65	38	3,8749	696,27	71	7,2400
58,840	6	0,6118	382,46	39	3,9769	706,08	72	7,3420
68,647	7	0,7138	392,27	40	4,0789	715,89	73	7,4439
78,453	8	0,8158	402,07	41	4,1808	725,69	74	7,5459
88,260	9	0,9177	411,88	42	4,2828	735,50	75	7,6479
98,066	10	1,0197	421,69	43	4,3848	745,31	76	7,7498
107,87	11	1,1217	431,49	44	4,4868	755,11	77	7,8518
117,68	12	1,2237	441,30	45	4,5887	764,92	78	7,9538
127,49	13	1,3256	451,11	46	4,6907	774,73	79	8,0558
137,29	14	1,4279	460,91	47	4,7927	784,53	80	8,1577
147,10	15	1,5296	470,72	48	4,8946	794,34	81	8,2597
156,91	16	1,6315	480,53	49	4,9966	804,15	82	8,3617
166,71	17	1,7335	490,33	50	5,0986	813,95	83	8,4636
176,52	18	1,8355	500,14	51	5,2006	823,76	84	8,5656
186,33	19	1,9375	509,95	52	5,3025	833,57	85	8,6676
196,13	20	2,0394	519,75	53	5,4045	843,37	86	8,7696
205,94	21	2,1414	529,56	54	5,5065	853,18	87	8,8715
215,75	22	2,2434	539,37	55	5,6084	862,99	88	8,9735
225,55	23	2,3453	549,17	56	5,7104	872,79	89	9,0755
235,36	24	2,4473	558,98	57	5,8124	882,60	90	9,1774
245,17	25	2,5493	568,79	58	5,9144	892,41	91	9,2794
254,97	26	2,6513	578,59	59	6,0163	902,21	92	9,3814
264,78	27	2,7532	588,40	60	6,1183	912,02	93	9,4834
274,59	28	2,8552	598,21	61	6,2203	921,83	94	9,5853
284,39	29	2,9572	608,01	62	6,3222	931,63	95	9,6873
294,20	30	3,0591	617,82	63	6,4242	941,44	96	9,7893
304,01	31	3,1611	627,63	64	6,5262	951,25	97	9,8912
313,81	32	3,2631	637,43	65	6,6282	961,05	98	9,9932
323,62	33	3,3651	647,24	66	6,7301	970,86	99	10,095

3. kg–lb Conversion Table

[How to Read] For example, to convert 10kg into lb, read the figure in the right lb column adjacent to the 10 in the center column in the 1st block. This means that 10kg is 22,046lb. To convert 10lb into kg, read the figure in the left kg column of the same row, which indicates that the answer is 4,536kg.

1kg = 2.2046226lb
1lb = 0.45359237kg

kg		lb	kg		lb	kg		lb
0,454	1	2,205	15,422	34	74,957	30,391	67	147,71
0,907	2	4,409	15,876	35	77,162	30,844	68	149,91
1,361	3	6,614	16,329	36	79,366	31,298	69	152,12
1,814	4	8,818	16,783	37	81,571	31,751	70	154,32
2,268	5	11,023	17,237	38	83,776	32,205	71	156,53
2,722	6	13,228	17,690	39	85,980	32,659	72	158,73
3,175	7	15,432	18,144	40	88,185	33,112	73	160,94
3,629	8	17,637	18,597	41	90,390	33,566	74	163,14
4,082	9	19,842	19,051	42	92,594	34,019	75	165,35
4,536	10	22,046	19,504	43	94,799	34,473	76	167,55
4,990	11	24,251	19,958	44	97,003	34,927	77	169,76
5,443	12	26,455	20,412	45	99,208	35,380	78	171,96
5,897	13	28,660	20,865	46	101,41	35,834	79	174,17
6,350	14	30,865	21,319	47	103,62	36,287	80	176,37
6,804	15	33,069	21,772	48	105,82	36,741	81	178,57
7,257	16	35,274	22,226	49	108,03	37,195	82	180,78
7,711	17	37,479	22,680	50	110,23	37,648	83	182,98
8,165	18	39,683	23,133	51	112,44	38,102	84	185,19
8,618	19	41,888	23,587	52	114,64	38,555	85	187,39
9,072	20	44,092	24,040	53	116,84	39,009	86	189,60
9,525	21	46,297	24,494	54	119,05	39,463	87	191,80
9,979	22	48,502	24,948	55	121,25	39,916	88	194,01
10,433	23	50,706	25,401	56	123,46	40,370	89	196,21
10,886	24	52,911	25,855	57	125,66	40,823	90	198,42
11,340	25	55,116	26,308	58	127,87	41,277	91	200,62
11,793	26	57,320	26,762	59	130,07	41,730	92	202,83
12,247	27	59,525	27,216	60	132,28	42,184	93	205,03
12,701	28	61,729	27,669	61	134,48	42,638	94	207,23
13,154	29	63,934	28,123	62	136,69	43,091	95	209,44
13,608	30	66,139	28,576	63	138,89	43,545	96	211,64
14,061	31	68,343	29,030	64	141,10	43,998	97	213,85
14,515	32	70,548	29,484	65	143,30	44,452	98	216,05
14,969	33	72,753	29,937	66	145,51	44,906	99	218,26

4. Hardness Conversion Table

Rockwell C-Scale Hardness (1 471N)	Vickers Hardness	Brinell Hardness		Rockwell Hardness		Shear Hardness
		Standard ball	Tungsten carbide ball	A Scale 588.4N (69kgf) brallel particle	B Scale 980.7N (100kgf) 1.588mm (1/16 in)	
68	940	–	–	85.6	–	97
67	900	–	–	85.0	–	95
66	865	–	–	84.5	–	92
65	832	–	739	83.9	–	91
64	800	–	722	83.4	–	88
63	772	–	705	82.8	–	87
62	746	–	688	82.3	–	85
61	720	–	670	81.8	–	83
60	697	–	654	81.2	–	81
59	674	–	634	80.7	–	80
58	653	–	615	80.1	–	78
57	633	–	595	79.6	–	76
56	613	–	577	79.0	–	75
55	595	–	560	78.5	–	74
54	577	–	543	78.0	–	72
53	560	–	525	77.4	–	71
52	544	500	512	76.8	–	69
51	528	487	496	76.3	–	68
50	513	475	481	75.9	–	67
49	498	464	469	75.2	–	66
48	484	451	455	74.7	–	64
47	471	442	443	74.1	–	63
46	458	432	432	73.6	–	62
45	446	421	421	73.1	–	60
44	434	409	409	72.5	–	58
43	423	400	400	72.0	–	57
42	412	390	390	71.5	–	56
41	402	381	381	70.9	–	55
40	392	371	371	70.4	–	54
39	382	362	362	69.9	–	52

Rockwell C-Scale Hardness (1 471N)	Vickers Hardness	Brinell Hardness		Rockwell Hardness		Shear Hardness
		Standard ball	Tungsten carbide ball	A Scale 588.4N (69kgf) brallel particle	B Scale 980.7N (100kgf) 1.588mm (1/16 in)	
38	372	353	353	69,4	–	51
37	363	344	344	68,9	–	50
36	354	336	336	68,4	(109,0)	49
35	345	327	327	67,9	(108,5)	48
34	336	319	319	67,4	(108,0)	47
33	327	311	311	66,8	(107,5)	46
32	318	301	301	66,3	(107,0)	44
31	310	294	294	65,8	(106,0)	43
30	302	286	286	65,3	(105,5)	42
29	294	279	279	64,7	(104,5)	41
28	286	271	271	64,3	(104,0)	41
27	279	264	264	63,8	(103,0)	40
26	272	258	258	63,3	(102,5)	38
25	266	253	253	62,8	(101,5)	38
24	260	247	247	62,4	(101,0)	37
23	254	243	243	62,0	100,0	36
22	248	237	237	61,5	99,0	35
21	243	231	231	61,0	98,5	35
20	238	226	226	60,5	97,8	34
(18)	230	219	219	–	96,7	33
(16)	222	212	212	–	95,5	32
(14)	213	203	203	–	93,9	31
(12)	204	194	194	–	92,3	29
(10)	196	187	187	–	90,7	28
(8)	188	179	179	–	89,5	27
(6)	180	171	171	–	87,1	26
(4)	173	165	165	–	85,5	25
(2)	166	158	158	–	83,5	24
(0)	160	152	152	–	81,7	24

5. Dimensional Tolerance of Axis

Diameter(mm)		d6	e6	f6	g5	g6	h5	h6	h7	h8	h9	h10	js5	js6
Above	Below													
3	6	-30 -38	-20 -28	-10 -18	-4 -9	-4 -12	0 -5	0 -8	0 -12	0 -18	0 -30	0 -48	±2.5	±4
6	10	-40 -49	-25 -34	-13 -22	-5 -11	-5 -14	0 -6	0 -9	0 -15	0 -22	0 -36	0 -58	±3	±4.5
10	18	-50 -61	-32 -43	-16 -27	-6 -14	-6 -17	0 -8	0 -11	0 -18	0 -27	0 -43	0 -70	±4	±5.5
18	30	-65 -78	-40 -53	-20 -33	-7 -16	-7 -20	0 -9	0 -13	0 -21	0 -33	0 -52	0 -84	±4.5	±6.5
30	50	-80 -96	-50 -66	-25 -41	-9 -20	-9 -25	0 -11	0 -16	0 -25	0 -39	0 -62	0 -100	±5.5	±8
50	80	-100 -119	-60 -79	-30 -49	-10 -23	-10 -29	0 -13	0 -19	0 -30	0 -46	0 -74	0 -120	±6.5	±9.5
80	120	-120 -142	-72 -94	-36 -58	-12 -27	-12 -34	0 -15	0 -22	0 -35	0 -54	0 -87	0 -140	±7.5	±11
120	180	-145 -170	-85 -110	-43 -68	-14 -32	-14 -39	0 -18	0 -25	0 -40	0 -63	0 -100	0 -160	±9	±12.5
180	250	-170 -199	-100 -129	-50 -79	-15 -35	-15 -44	0 -20	0 -29	0 -46	0 -72	0 -115	0 -185	±10	±14.5
250	315	-190 -222	-110 -142	-56 -88	-17 -40	-17 -49	0 -23	0 -32	0 -52	0 -81	0 -130	0 -210	±11.5	±16
315	400	-210 -246	-125 -161	-62 -98	-18 -43	-18 -54	0 -25	0 -36	0 -57	0 -89	0 -140	0 -230	±12.5	±18
400	500	-230 -270	-135 -175	-68 -108	-20 -47	-20 -60	0 -27	0 -40	0 -63	0 -97	0 -155	0 -250	±13.5	±20
500	630	-260 -304	-145 -189	-76 -120	-	-22 -66	-	0 -44	0 -70	0 -110	0 -175	0 -280	-	±22
630	800	-290 -340	-160 -210	-80 -130	-	-24 -74	-	0 -50	0 -80	0 -125	0 -200	0 -320	-	±25
800	1000	-320 -376	-170 -226	-86 -142	-	-26 -82	-	0 -56	0 -90	0 -140	0 -230	0 -360	-	±28
1000	1250	-350 -416	-195 -261	-98 -164	-	-28 -94	-	0 -66	0 -105	0 -165	0 -260	0 -420	-	±33
1250	1600	-390 -468	-220 -298	-110 -188	-	-30 -108	-	0 -78	0 -125	0 -195	0 -310	0 -500	-	±39
1600	2000	-430 -522	-240 -332	-120 -212	-	-32 -124	-	0 -92	0 -150	0 -230	0 -370	0 -600	-	±46

j5	j6	j7	k5	k6	k7	m5	m6	n6	p6	r6	r7	Diameter(mm)	
												Above	Below
+3 -2	+6 -2	+8 -4	+6 +1	+9 +1	+13 +1	+9 +4	+12 +4	+16 +8	+20 +12	+23 +15	+27 +15	3	6
+4 -2	+7 -2	+10 -0	+7 +1	+10 +1	+16 +1	+12 +6	+15 +6	+19 +10	+24 +15	+28 +19	+34 +19	6	10
+5 -3	+8 -3	+12 -6	+9 +1	+12 +1	+19 +1	+15 +7	+18 +7	+23 +12	+29 +18	+34 +23	+41 +23	10	18
+5 -4	+9 -4	+13 -8	+11 +2	+15 +2	+23 +2	+17 +8	+21 +8	+28 +15	+35 +22	+41 +28	+49 +28	18	30
+6 -3	+11 -5	+15 -10	+13 +2	+18 +2	+27 +2	+20 +9	+25 +9	+33 +17	+42 +26	+50 +34	+59 +34	30	50
+6 -7	+12 -7	+18 -12	+15 + 2	+21 + 2	+32 + 2	+24 + 11	+30 + 11	+39 +20	+51 +32	+60 +41	+71 +41	50	65
+6 -9	+13 -9	+20 -15	+18 + 3	+25 + 3	+38 + 3	+28 +13	+35 +13	+45 +23	+59 +37	+62 +43	+73 +43	65	80
+6 -11	+13 -11	+20 -18	+18 + 3	+25 + 3	+38 + 3	+28 +15	+35 +15	+45 +27	+59 +43	+73 +51	+86 +51	80	100
+6 -11	+13 -11	+20 -18	+18 + 3	+25 + 3	+38 + 3	+28 +15	+35 +15	+45 +27	+59 +43	+76 +54	+89 +54	100	120
+6 -11	+13 -11	+20 -18	+18 + 3	+25 + 3	+38 + 3	+28 +15	+35 +15	+45 +27	+59 +43	+88 +63	+103 +63	120	140
+6 -11	+13 -11	+20 -18	+18 + 3	+25 + 3	+38 + 3	+28 +15	+35 +15	+45 +27	+59 +43	+90 +65	+105 +65	140	160
+6 -11	+13 -11	+20 -18	+18 + 3	+25 + 3	+38 + 3	+28 +15	+35 +15	+45 +27	+59 +43	+93 +68	+108 +68	160	180
+6 -11	+13 -11	+20 -18	+18 + 3	+25 + 3	+38 + 3	+28 +15	+35 +15	+45 +27	+59 +43	+106 +77	+123 +77	180	200
+6 -11	+13 -11	+20 -18	+18 + 3	+25 + 3	+38 + 3	+28 +15	+35 +15	+45 +27	+59 +43	+109 +80	+126 +80	200	225
+6 -11	+13 -11	+20 -18	+18 + 3	+25 + 3	+38 + 3	+28 +15	+35 +15	+45 +27	+59 +43	+113 +84	+130 +84	225	250
+6 -11	+13 -11	+20 -18	+18 + 3	+25 + 3	+38 + 3	+28 +15	+35 +15	+45 +27	+59 +43	+126 +94	+146 +94	250	280
+6 -11	+13 -11	+20 -18	+18 + 3	+25 + 3	+38 + 3	+28 +15	+35 +15	+45 +27	+59 +43	+130 +98	+150 +98	280	315
+6 -11	+13 -11	+20 -18	+18 + 3	+25 + 3	+38 + 3	+28 +15	+35 +15	+45 +27	+59 +43	+144 +108	+165 +108	315	355
+6 -11	+13 -11	+20 -18	+18 + 3	+25 + 3	+38 + 3	+28 +15	+35 +15	+45 +27	+59 +43	+150 +114	+171 +114	355	400
+6 -11	+13 -11	+20 -18	+18 + 3	+25 + 3	+38 + 3	+28 +15	+35 +15	+45 +27	+59 +43	+166 +126	+189 +126	400	450
+6 -11	+13 -11	+20 -18	+18 + 3	+25 + 3	+38 + 3	+28 +15	+35 +15	+45 +27	+59 +43	+172 +132	+195 +132	450	500
+6 -11	+13 -11	+20 -18	+18 + 3	+25 + 3	+38 + 3	+28 +15	+35 +15	+45 +27	+59 +43	+194 +155	+220 +155	500	560
+6 -11	+13 -11	+20 -18	+18 + 3	+25 + 3	+38 + 3	+28 +15	+35 +15	+45 +27	+59 +43	+199 +155	+225 +155	560	630
+6 -11	+13 -11	+20 -18	+18 + 3	+25 + 3	+38 + 3	+28 +15	+35 +15	+45 +27	+59 +43	+225 +175	+255 +175	630	710
+6 -11	+13 -11	+20 -18	+18 + 3	+25 + 3	+38 + 3	+28 +15	+35 +15	+45 +27	+59 +43	+235 +185	+265 +185	710	800
+6 -11	+13 -11	+20 -18	+18 + 3	+25 + 3	+38 + 3	+28 +15	+35 +15	+45 +27	+59 +43	+266 +210	+300 +210	800	900
+6 -11	+13 -11	+20 -18	+18 + 3	+25 + 3	+38 + 3	+28 +15	+35 +15	+45 +27	+59 +43	+276 +220	+310 +220	900	1000
+6 -11	+13 -11	+20 -18	+18 + 3	+25 + 3	+38 + 3	+28 +15	+35 +15	+45 +27	+59 +43	+316 +250	+355 +250	1000	1120
+6 -11	+13 -11	+20 -18	+18 + 3	+25 + 3	+38 + 3	+28 +15	+35 +15	+45 +27	+59 +43	+326 +260	+365 +260	1120	1250
+6 -11	+13 -11	+20 -18	+18 + 3	+25 + 3	+38 + 3	+28 +15	+35 +15	+45 +27	+59 +43	+378 +300	+425 +300	1250	1400
+6 -11	+13 -11	+20 -18	+18 + 3	+25 + 3	+38 + 3	+28 +15	+35 +15	+45 +27	+59 +43	+408 +330	+455 +330	1400	1600
+6 -11	+13 -11	+20 -18	+18 + 3	+25 + 3	+38 + 3	+28 +15	+35 +15	+45 +27	+59 +43	+462 +370	+520 +370	1600	1800
+6 -11	+13 -11	+20 -18	+18 + 3	+25 + 3	+38 + 3	+28 +15	+35 +15	+45 +27	+59 +43	+492 +400	+550 +400	1800	2000

6. Dimensional Tolerance of Housing Hole

Diameter(mm)		E6	F6	F7	G6	G7	H6	H7	H8	J6	J7	JS6	JS7
Above	Below												
10	18	+43 +32	+27 +16	+34 +16	+17 +6	+24 +6	+11 0	+18 0	+27 0	+6 -5	+10 -8	±5,5	±9
18	30	+53 +40	+33 +20	+41 +20	+20 +7	+28 +7	+13 0	+21 0	+33 0	+8 -5	+12 -9	±6,5	±10,5
30	50	+66 +50	+41 +25	+50 +25	+25 +9	+34 +9	+16 0	+25 0	+39 0	+10 -6	+14 -11	±8	±12,5
50	80	+79 +60	+49 +30	+60 +30	+29 +10	+40 +10	+19 0	+30 0	+46 0	+13 -6	+18 -12	±9,5	±15
80	120	+94 +72	+58 +36	+71 +36	+34 +12	+47 +12	+22 0	+35 0	+54 0	+16 -6	+22 -13	±11	±17,5
120	180	+110 +85	+68 +43	+83 +43	+39 +14	+54 +14	+25 0	+40 0	+63 0	+18 -7	+26 -14	±12,5	±20
180	250	+129 +100	+79 +50	+96 +50	+44 +15	+61 +15	+29 0	+46 0	+72 0	+22 -7	+30 -16	±14,5	±23
250	315	+142 +110	+88 +56	+108 +56	+49 +17	+69 +17	+32 0	+52 0	+81 0	+25 -7	+36 -16	±16	±26
315	400	+161 +125	+98 +62	+119 +62	+54 +18	+75 +18	+36 0	+57 0	+89 0	+29 -7	+39 -18	±18	±28,5
400	500	+175 +135	+108 +68	+131 +68	+60 +20	+83 +20	+40 0	+63 0	+97 0	+33 -7	+43 -20	±20	±31,5
500	630	+189 +145	+120 +76	+146 +76	+66 +22	+92 +22	+44 0	+70 0	+110 0	-	-	±22	±35
630	800	+210 +160	+130 +80	+160 +80	+74 +24	+104 +24	+50 0	+80 0	+125 0	-	-	±25	±40
800	1000	+226 +170	+142 +86	+176 +86	+82 +26	+116 +26	+56 0	+90 0	+140 0	-	-	±28	±45
1000	1250	+261 +195	+164 +98	+203 +98	+94 +28	+133 +28	+66 0	+105 0	+165 0	-	-	±33	±52,5
1250	1600	+298 +220	+188 +110	+235 +110	+108 +30	+155 +30	+78 0	+125 0	+195 0	-	-	±39	±62,5
1600	2000	+332 +240	+212 +120	+270 +120	+124 +32	+182 +32	+92 0	+150 0	+230 0	-	-	±46	±75
2000	2500	+370 +260	+240 +130	+305 +130	+144 +34	+209 +34	+110 0	+175 0	+280 0	-	-	±55	±87,5

K5	K6	K7	M5	M6	M7	N5	N6	N7	P6	P7	Diameter(mm)	
											Above	Below
+2 -6	+2 -9	+6 -12	-4 -12	-4 -15	0 -18	-9 -17	-9 -20	-5 -23	-15 -26	-11 -29	10	18
+1 -8	+2 -11	+6 -15	-5 -14	-4 -17	0 -21	-12 -21	-11 -24	-7 -28	-18 -31	-14 -35	18	30
+2 -9	+3 -13	+7 -18	-5 -16	-4 -20	0 -25	-13 -24	-12 -28	-8 -33	-21 -37	-17 -42	30	50
+3 -10	+4 -15	+9 -21	-6 -19	-5 -24	0 -30	-15 -28	-14 -33	-9 -39	-26 -45	-21 -51	50	80
+2 -13	+4 -18	+10 -25	-8 -23	-6 -28	0 -35	-18 -33	-16 -38	-10 -45	-30 -52	-24 -59	80	120
+3 -15	+4 -21	+12 -28	-9 -27	-8 -33	0 -40	-21 -39	-20 -45	-12 -52	-36 -61	-28 -68	120	180
+2 -18	+5 -24	+13 -33	-11 -31	-8 -37	0 -46	-25 -45	-22 -51	-14 -60	-41 -70	-33 -79	180	250
+3 -20	+5 -27	+16 -36	-13 -36	-9 -41	0 -52	-27 -50	-25 -57	-14 -66	-47 -79	-36 -88	250	315
+3 -22	+7 -29	+17 -40	-14 -39	-10 -46	0 -57	-30 -55	-26 -62	-16 -73	-51 -87	-41 -98	315	400
+2 -25	+8 -32	+18 -45	-16 -43	-10 -50	0 -63	-33 -60	-27 -67	-17 -80	-55 -95	-45 -108	400	500
-	0 -44	0 -70	-	-26 -70	-26 -96	-	-44 -88	-44 -114	-78 -122	-78 -148	500	630
-	0 -50	0 -80	-	-30 -80	-30 -110	-	-50 -100	-50 -130	-88 -138	-88 -168	630	800
-	0 -56	0 -90	-	-34 -90	-34 -124	-	-56 -112	-56 -146	-100 -156	-100 -190	800	1000
-	0 -66	0 -105	-	-40 -106	-40 -145	-	-66 -132	-66 -171	-120 -186	-120 -225	1000	1250
-	0 -78	0 -125	-	-48 -126	-48 -173	-	-78 -156	-78 -203	-140 -218	-140 -265	1250	1600
-	0 -92	0 -150	-	-58 -150	-58 -208	-	-92 -184	-92 -242	-170 -262	-170 -320	1600	2000
-	0 -110	0 -175	-	-68 -178	-68 -243	-	-110 -220	-110 -285	-195 -305	-195 -370	2000	2500

7. Usage examples of Linear Motion Guide

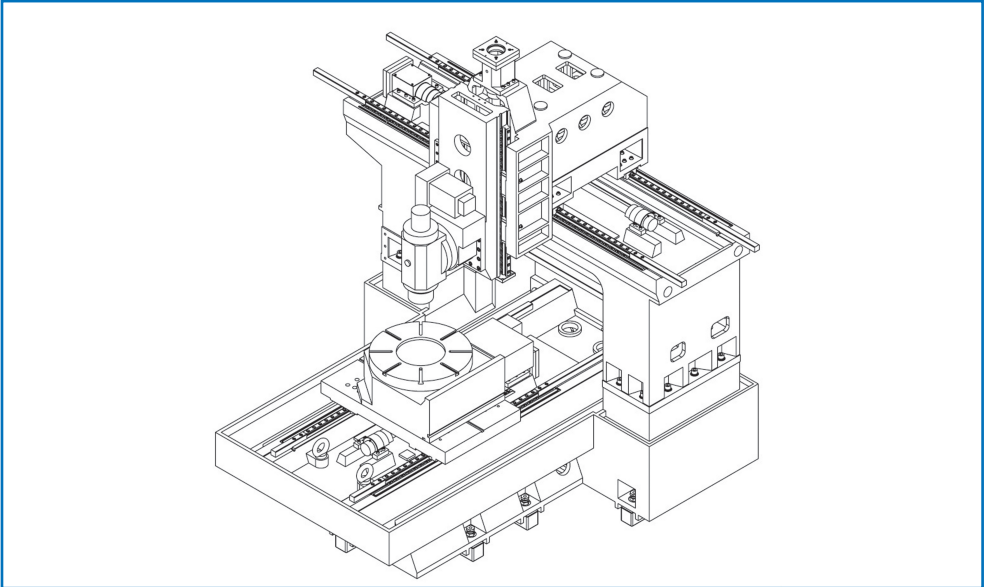
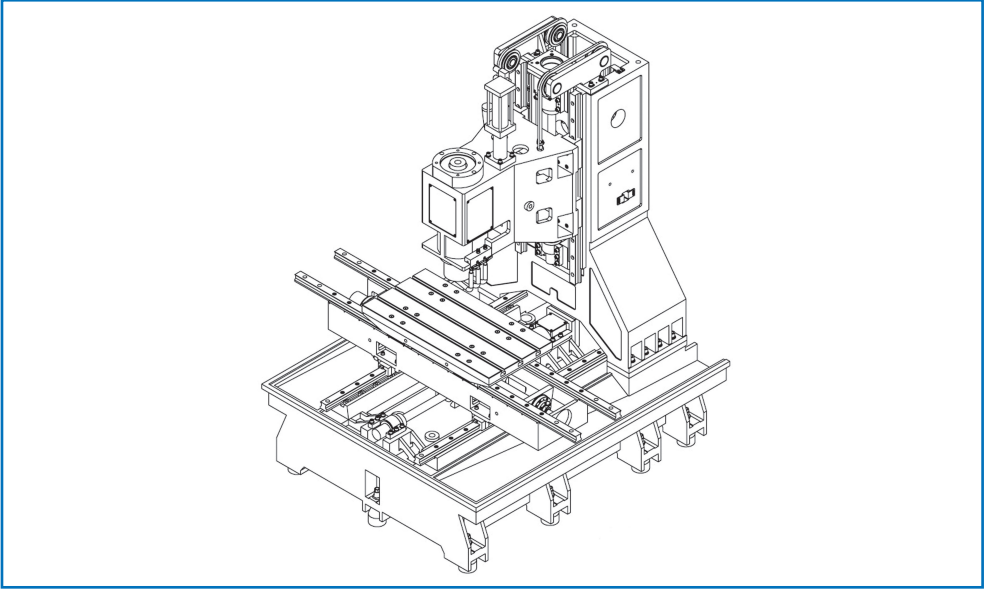

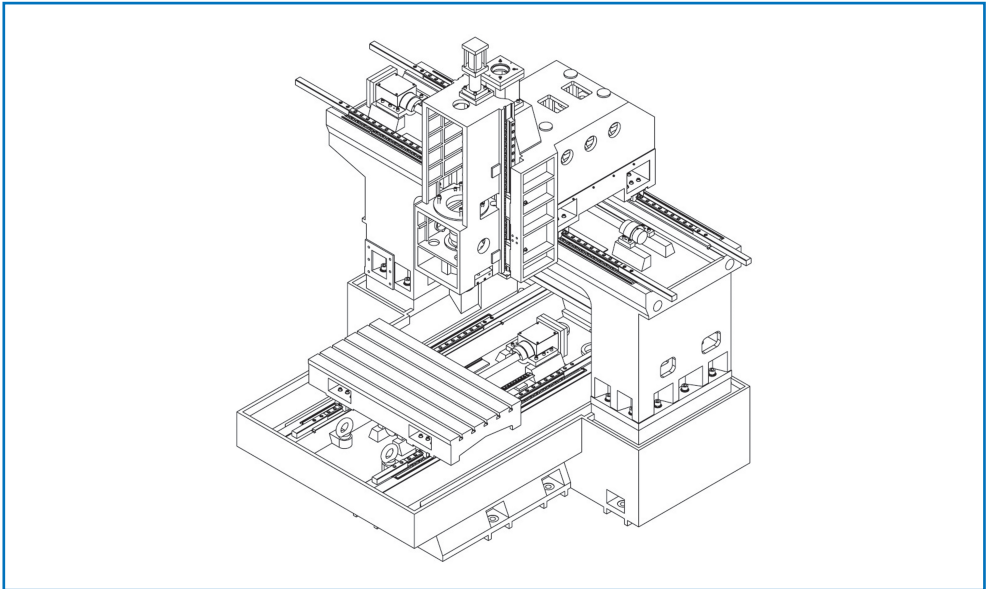
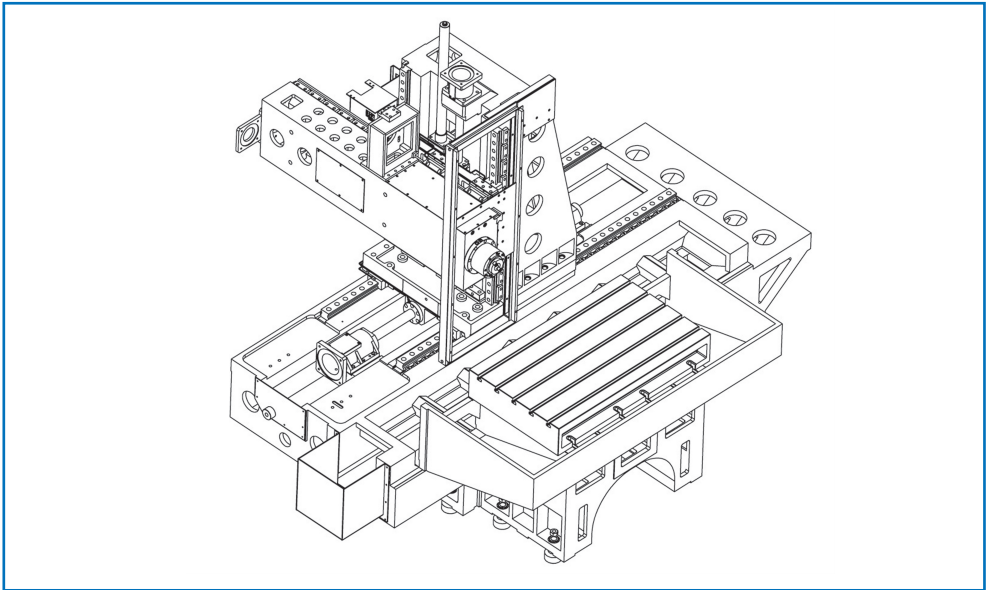

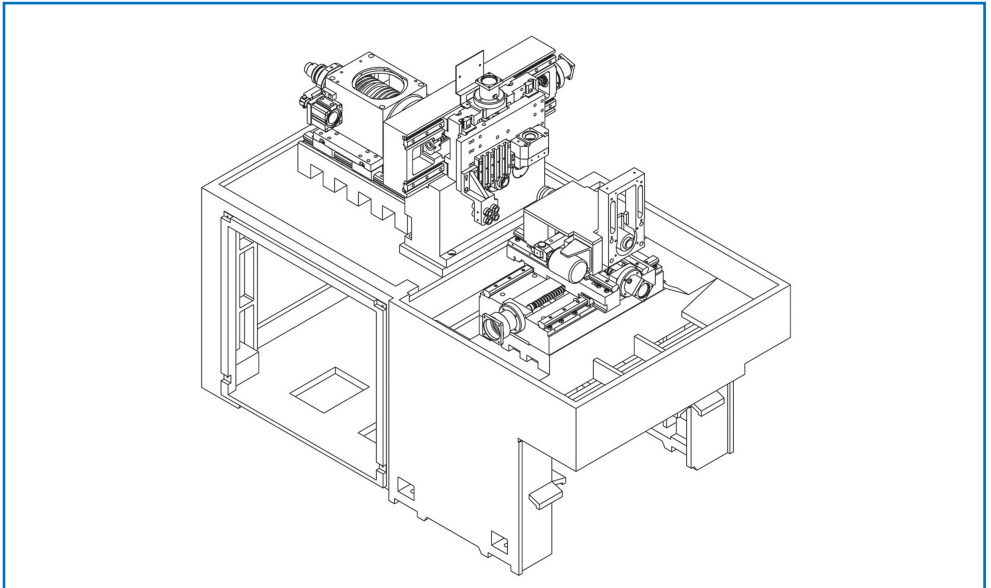
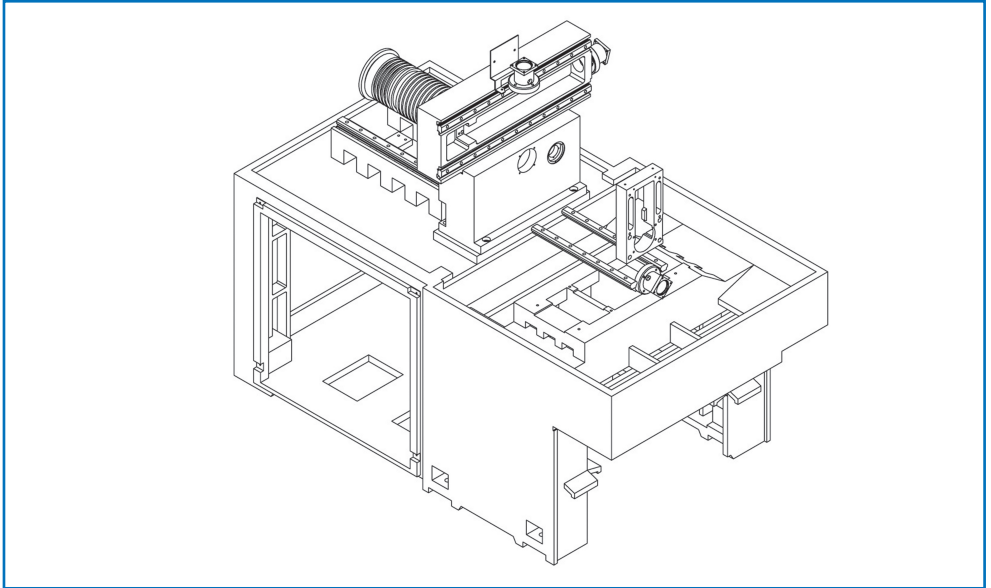

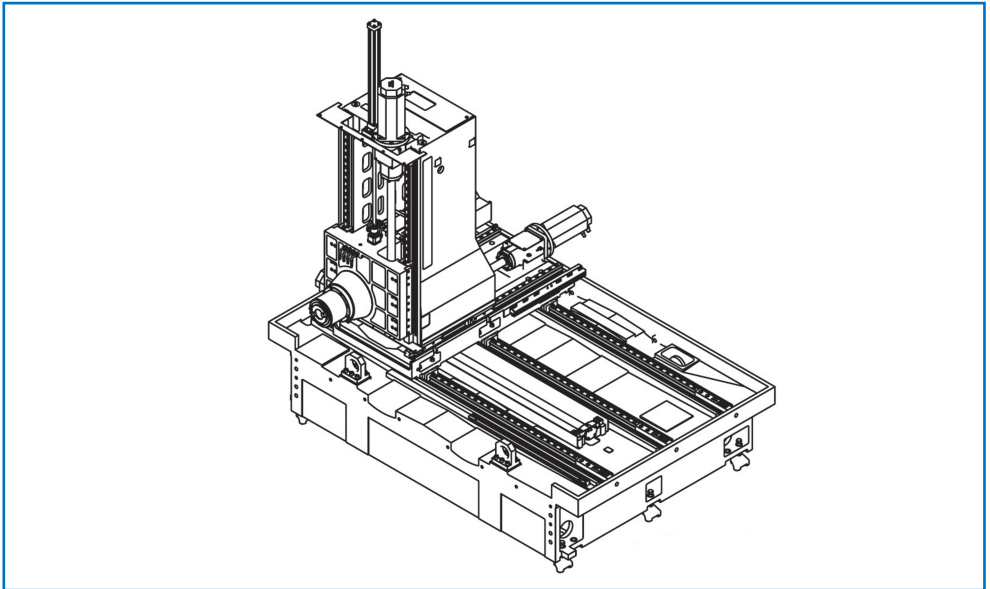
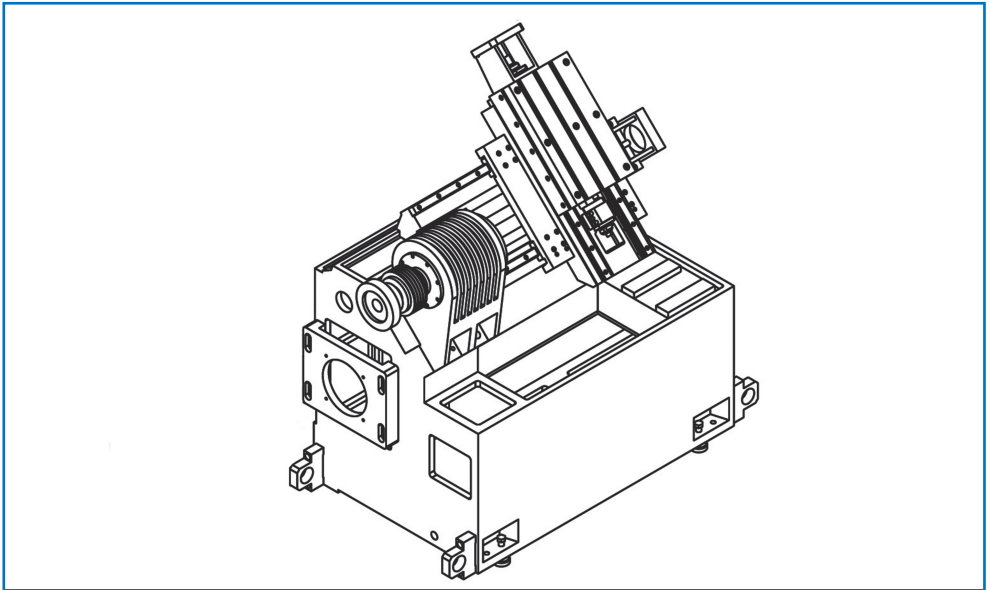

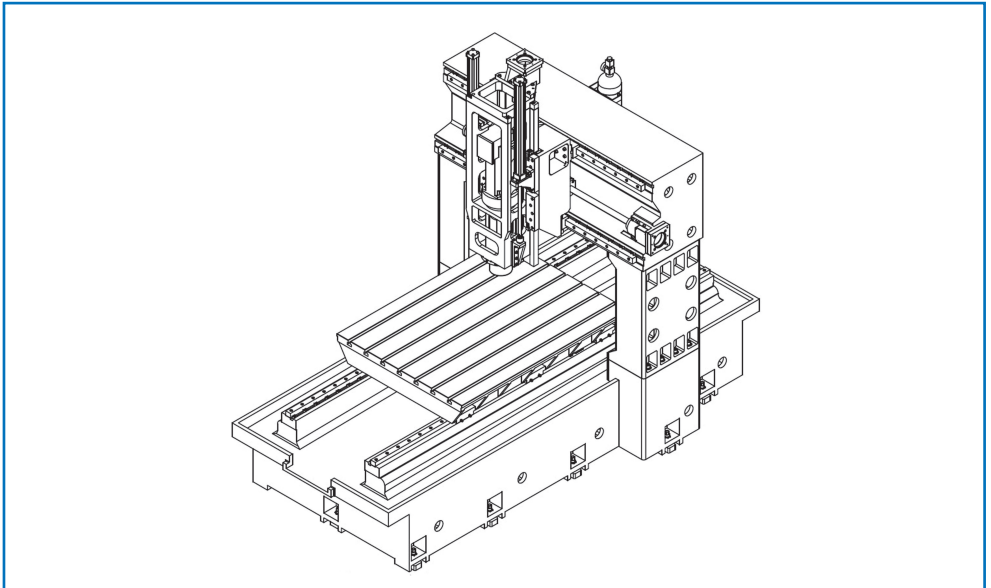
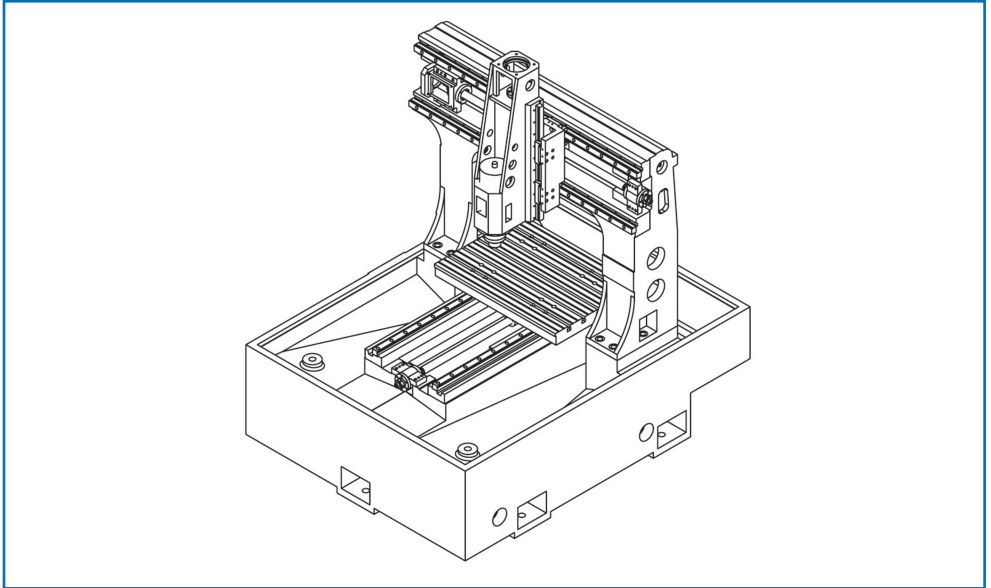

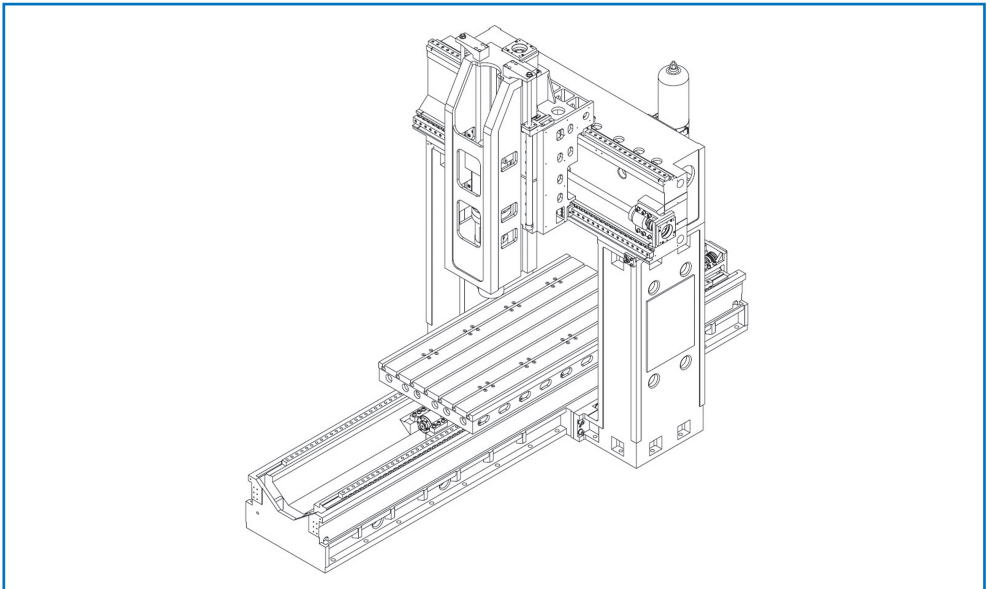
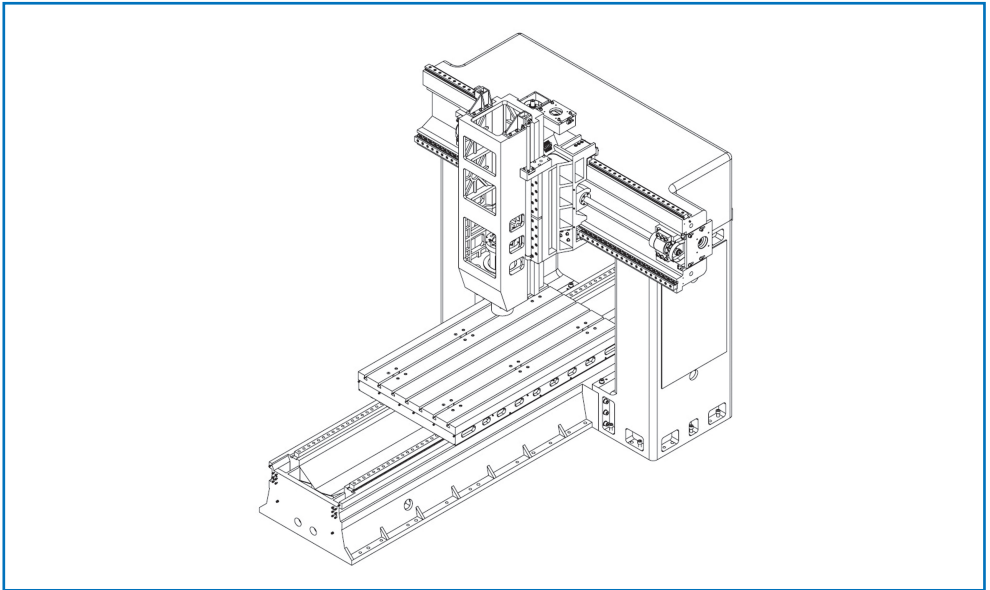

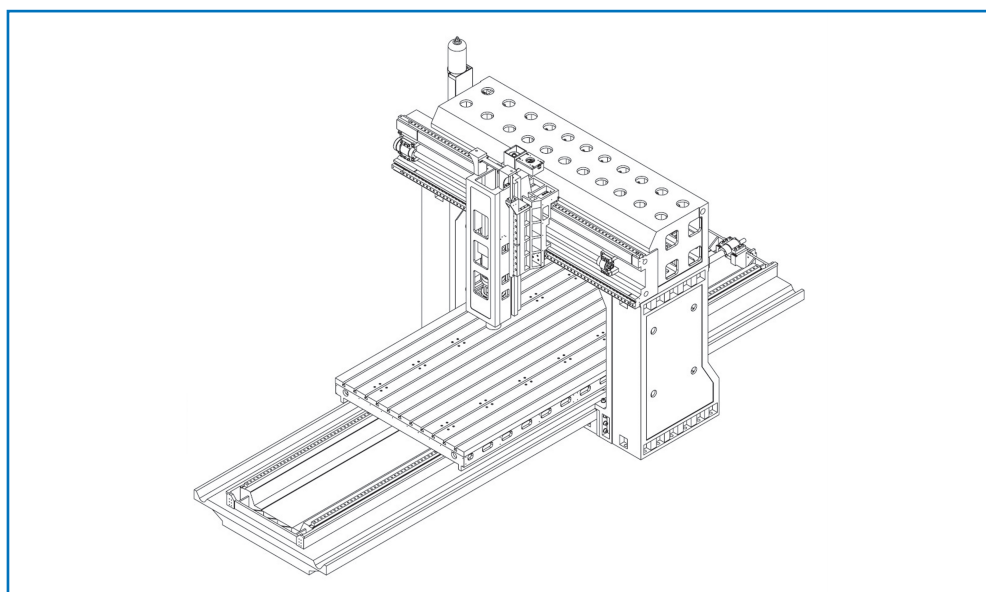
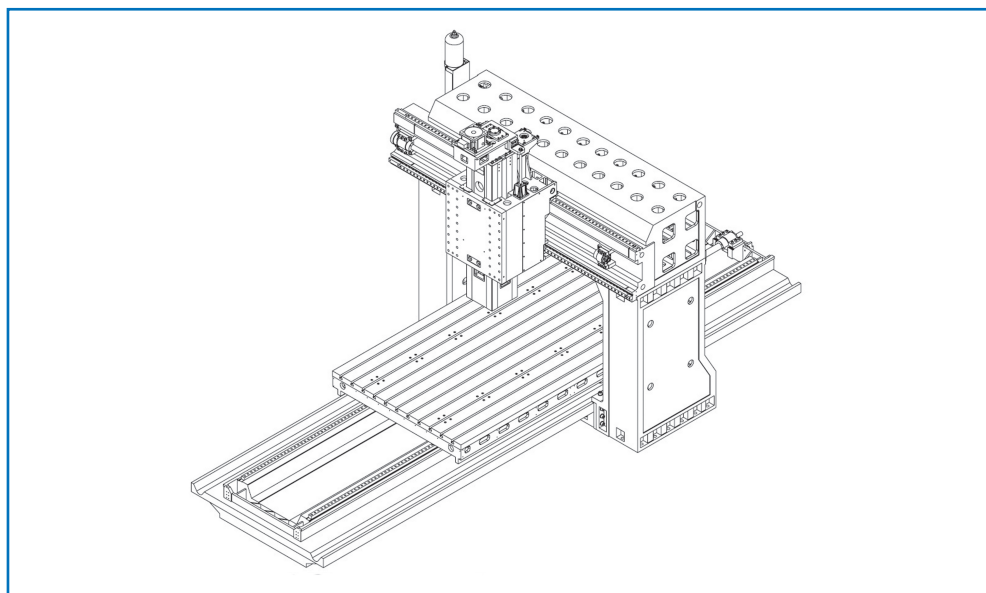

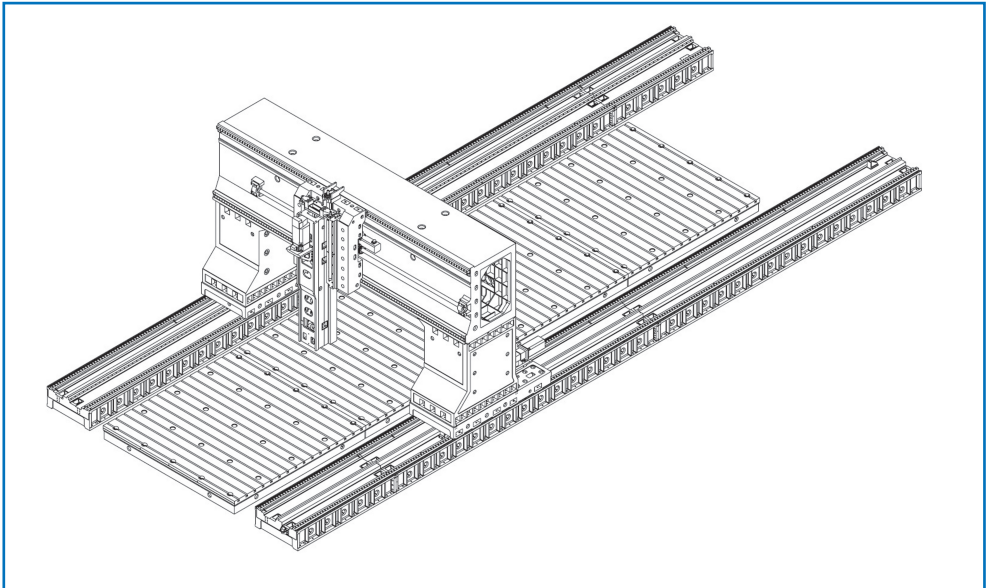
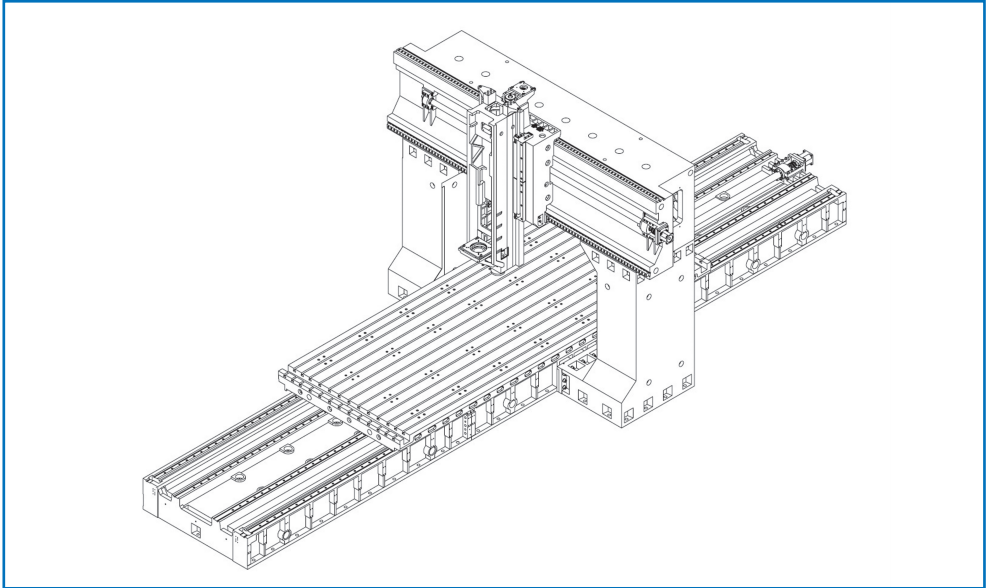

8. Usage examples of Crossed Roller Bearing

